

Low pressure gauge with aluminium case

Model: P430 series

Spec. sheet no. PD04-05

Service intended

P430 series are designed to measure low, vacuum or compound pressure. These models have a stainless steel 316L measuring element which consists of two formed diaphragms and diaphragms are welded together.

ERC

Nominal diameter

100 and 150 mm

Accuracy

±1.0 % of full scale

±1.5 % of full scale

Scale range (kPa, mbar)

-35 ~ 0 to -1 ~ 0 kPa

-15 ~ 15 to -0.5 ~ 0.5 kPa

0 ~ 1 to 0 ~ 35 kPa

Working pressure

Steady : 75 % of full scale

Over range protection : 130 % of full scale

Working temperature

Ambient : -20 ~ 65 °C

Fluid : Max. 100 °C

Temperature effect

Accuracy at temperature above and below the reference temperature (20 °C) will be effected by approximately ±0.4 % per 10 °C of full scale



Standard features

Pressure connection

Stainless steel (316SS)

Movement

Brass

Element

Stainless steel (316L SS)

Pressure chamber : Up to 35 kPa

Dial

White aluminium with black graduations

Case

Black finished aluminium

Pointer

Black painted aluminium alloy

Cover

Black finished aluminium

Window

Safety glass

Process connection

3/8", 1/2" PT, NPT and PF

WISE[®]

| P430_01

1. Base model

P430 Low pressure gauge with aluminium case

2. Nominal diameter (mm)

- 4 100
- 6 150

3. Type of mounting

- A** Bottom connection, direct
- F** Center back connection, direct, not available with diameter 150 mm
- J** Center back connection, flush, cover mounting plate, not available with diameter 150 mm

4. Accuracy

- 3 ±1.0 % of full scale
- 4 ±1.5 % of full scale

5. Process connection

- D** 3/8"
- E** 1/2"

6. Connection type

- B** PF
- C** PT
- D** NPT

7. Unit

- J** kPa
- S** mbar

8. Range

XXX Refer to pressure unit and range table

9. Pressure connection material and dial color

- 3 316SS and 2 colors

10. Option

- 0 None
- 1 Accessories
- 2 Orifice
- 3 Accessories and orifice

1	2	3	4	5	6	7	8	9	10	Sample ordering code
P430	4	A	3	D	B	J	XXX	3	0	

P430 : Type of mounting

Code A

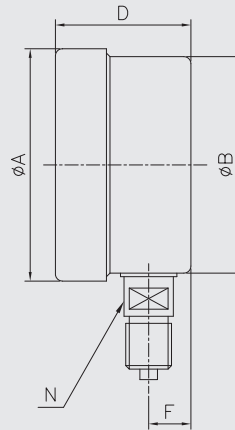
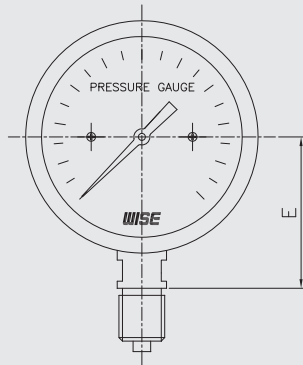

Code F

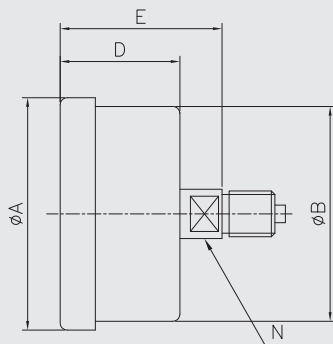
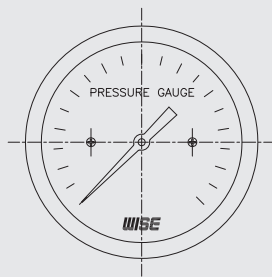

Code J

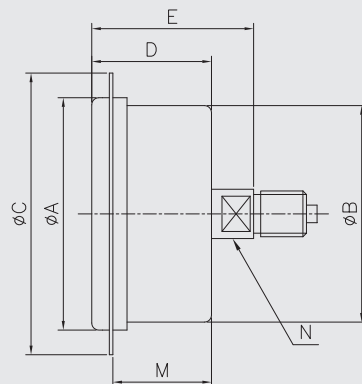
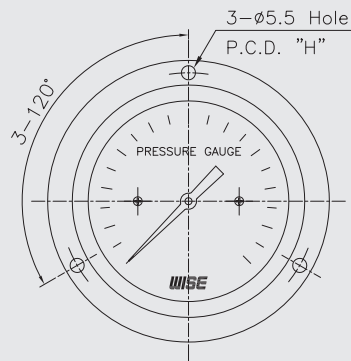

Dimensions (mm)

Dial size	Available code	A	B	C	D ± 2	E ± 2	F ± 1	H	M	N
100	A	110	105	130	63	80	26	118		17
	F,J	110	105	136	63	79		120	55	17
150	A	172	159	182	65	116	27	172		17

Pressure unit and range table

Range and code	Unit and code		Nominal diameter	
	S : mbar	J : kPa	100 mm	150 mm
503	-350 ~ 0	-35 ~ 0	O	O
400	-300 ~ 0	-30 ~ 0	O	O
502	-250 ~ 0	-25 ~ 0	O	O
401	-200 ~ 0	-20 ~ 0	O	O
402	-150 ~ 0	-15 ~ 0	O	O
403	-100 ~ 0	-10 ~ 0	O	O
405	-50 ~ 0	-5 ~ 0	O	O
406	-40 ~ 0	-4 ~ 0	O	O
407	-30 ~ 0	-3 ~ 0	O	O
408	-20 ~ 0	-2 ~ 0	O	O
409	-10 ~ 0	-1 ~ 0	X	O
472	-150 ~ 150	-15 ~ 15	O	O
470	-100 ~ 100	-10 ~ 10	O	O
413	-50 ~ 50	-5 ~ 5	O	O
415	-40 ~ 40	-4 ~ 4	O	O
417	-30 ~ 30	-30 ~ 30	O	O
418	-25 ~ 25	-2.5 ~ 2.5	O	O
419	-20 ~ 20	-2 ~ 2	O	O
421	-10 ~ 10	-1 ~ 1	O	O
457	0 ~ 10	0 ~ 1	X	O
460	0 ~ 20	0 ~ 2	O	O
462	0 ~ 30	0 ~ 3	O	O
464	0 ~ 40	0 ~ 4	O	O
465	0 ~ 50	0 ~ 5	O	O
469	0 ~ 100	0 ~ 10	O	O
515	0 ~ 150	0 ~ 15	O	O
437	0 ~ 200	0 ~ 20	O	O
517	0 ~ 250	0 ~ 25	O	O
518	0 ~ 300	0 ~ 30	O	O
519	0 ~ 350	0 ~ 35	O	O

O : Available X : Not available