

Differential pressure transmitter

Model: SMT2001

Spec. sheet no. SD02-01

Service intended

The high performance pressure transmitter SMT2001 is suitable to measure liquid, gas, or steam flow as well as liquid level, density and pressure.

The key features include quick response, remote set-up using communications, self-diagnostics and optional status output for pressure high/low alarm.



Degree of protection

EN60529/IEC529/IP66
EN60529/IEC529/IP67

Standard features

Accuracy

±0.05 % of calibrated span.
±0.075 % of calibrated span.

Range limits

1 kPa ~ 3 MPa

Turn down

Adjustable up to 100:1 range ability

Temperature compensation

High sensitivity temperature sensor packaged in the sensor

Isolating diaphragm

Stainless steel 316L
Hastelloy C
Stainless steel 316L with gold plated
Stainless steel 316L with Teflon plated

Measurement medium

Gas, steam and liquid

Stability

10 years stability
0.15 % of URL

Output

4 ~ 20 mA with HART protocol

WISE[®]

| SMT2001_01

Principle of operation

The differential pressure transmitter includes two functional units: Main unit / auxiliary unit

The main unit includes a sensor and process connection.

The completely welded sensor module is a twin-chamber system with an integral overload diaphragm, an absolute pressure sensor, a temperature sensor and the silicon differential pressure sensor.

The absolute pressure sensor, which is only exposed to the pressure at the high pressure side, acts as a reference value to compensate for the static pressure.

The temperature sensor as a temperature compensated reference value to compensate for the temperature drift.

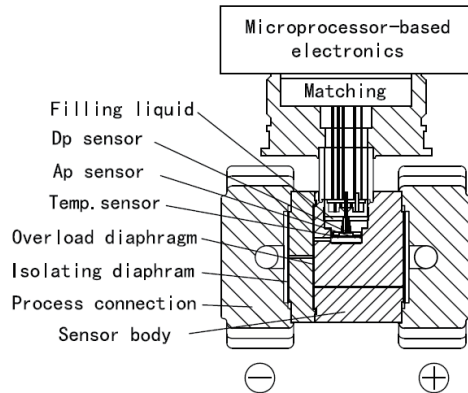

Main specification

- The differential pressure transmitter utilize the world's leading high stability silicon sensor, the highest Reference Accuracy is $\pm 0.05\%$
- Micro-differential pressure transmitter utilize the world's leading dual overload diaphragm patented technology, the highest Reference Accuracy is $\pm 0.05\%$
- The differential pressure transmitter's working pressure are 16 MPa, 25 MPa and 40 MPa, the one-way limited pressure up to 16 MPa, 25 MPa and 40 MPa
- The absolute pressure sensor packaged in the differential pressure transmitter, can be used for static pressure measurement, display and the static pressure compensation. The minimum of the static error is $\leq \pm 0.05\% / 10\text{ MPa}$
- High sensitivity temperature sensor packaged in the sensor. The minimum of the temperature error is $\leq \pm 0.04\% / 10\text{K}$
- Stainless steel 316L and silicone oil filling welded seal structure
- Long stability is $\leq \pm 0.1\% / 3\text{years}$, 10 years of maintenance-free
- Adjustable up to 100:1 range ability
- The remote seal transmitter utilize ultra-high temperature ($400\text{ }^\circ\text{C}$) patented technology.

Standard Specifications

Performance Specifications

Reference Accuracy of Calibrated Span (includes terminal-based linearity, hysteresis, and repeatability)
 $\pm 0.075\%$ If $TD > 10$ ($TD = URL / SPAN$), $\pm(0.075 \times TD)\%$

The square root accuracy is 1.5 times of reference accuracy of calibrated span.

Ambient Temperature Effects

$-20 \sim 65\text{ }^\circ\text{C} : \pm(0.2 \times TD + 0.05)\% \times \text{Span}$

Every $10\text{ }^\circ\text{C}$ is $\pm 0.08\% \times \text{Span}$ ($TD=1$)

$-40 \sim -20\text{ }^\circ\text{C}$ and $65 \sim 85\text{ }^\circ\text{C} : \pm(0.3 \times TD + 0.1)\% \times \text{Span}$

Static Pressure Effects

$\pm(0.05\% \text{URL} + 0.075\% \text{Span}) / 10\text{ MPa}$

Overpressure Effects

$\pm 0.1\% \times \text{Span} / 10\text{ MPa}$

Stability

$\pm 0.1\% \times \text{Span} / 3\text{ years}$

Power Supply Effects

$\pm 0.001\% / 10\text{ V}$ ($12 \sim 42\text{ V DC}$)

Explosion protection

Ex db IIC T4/T5/T6 Gb

Ex tb IIIC T80 °C / T90 °C / T130 °C Db

Ta = -40 to $+60\text{ }^\circ\text{C}$

Ex d IIC T6

Temperature class Max. process temperature

T4 T130°C 130°C

T5 T90°C 90°C

T6 T80°C 80°C

Functional Specifications

Span and Range Limits

Sensor	A	B	C	D	E
Pressure range (bar)	10 mbar	60 mbar	400 mbar	2.5 bar	30 bar
Setting limits (offset and span in this range freely adjustable)	-10 ... 10 mbar	-60 ... 60 mbar	-400 ... 400 mbar	-2.5 ... 2.5 bar	-30 ... 30 bar
Lowest permissible span	1 mbar	2 mbar	4 mbar	25 mbar	0.3 bar
Permissible static pressure (Option)	70 bar	160 bar	160 bar		
			250 bar		
			400 bar		
Range ability turndown (with respect to the differential pressure range)	10:1	30:1	100:1		

Turn-Down Accuracy

If the Accuracy is (%): 0.075

Turn-down $\leq 10:1 \leq \pm 0.075\% \text{ FSO}$

Turn-down $> 10:1 \leq \pm[0.075 \times \text{Turn-down}]\% \text{ FSO} \pm 0.075\%$

Turn-down = Nominal Pressure Range / Adjusted

Zero Adjustment Limits

Zero can be fully elevated or suppressed, within the lower and upper range limits of the capsule.

Standard Specifications

External Zero Adjustment

External zero is continuously adjustable with 0.01 % incremental resolution of span. Re-range can be done locally using the range setting switch.

Mounting Position Effects

Rotation in diaphragm plane has no effect. Tilting up to 90° will cause zero shift up to 0.4 kPa which can be corrected by the zero adjustment.

Output

2 wire 4~20 mA DC output with digital communications, linear or square root programmable. HART FSK protocol are superimposed on the 4~20 mA DC signal.
Output range: 3.9 mA to 20.5 mA.

Failure Alarm (The mode can be selected)

Low Alarm Mode (Min): 3.6 mA
High Alarm Mode (Max): 21 mA
Alarm Off (Keep): Keep the effective value before the fault.

- * Compliant with NAMUR NE-43
- * Note: The standard setting of failure alarm is High Mode.

Response Time

The amplifier damping constant is 0.1 sec.
The sensor damping constant is 0.1~1.6 sec, it depends on the range and range compression ratio.
Amplifier damping time constant is adjustable from 0.1 to 60 sec by software and added to response time.

Warm Up Time

< 15s

Permissible Temperatures

Environment / storage without display : -40 to 85 °C
with display : -20 to 65 °C
Media wetted parts / Filled oil : -40 to 100 °C
(Info: +125°C short time, max. 30 min.)

Working Pressure Limits (Silicone oil)

Maximum working pressure : 16 MPa (Option : 25 and 40 MPa)

One-way limited pressure

The maximum one-way limited pressure is maximum working pressure.

Standard Specifications

HART digital communication and 4 to 20 mA output Power Supply

The transmitter operates from 12 to 42 V DC with no load and is protected against reverse polarity connection
Minimum operating voltage increase to 12 V DC with surge protector

Ripple

20 mV max on a 250 Ω load as per HART specifications.

Load limitations

4 to 20 mA and HART total loop resistance :

$$R (\Omega) = \frac{\text{Supply voltage} - \text{min. operating voltage (V DC)}}{22 \text{ mA}}$$

A minimum of 250 Ω is required for HART communication.

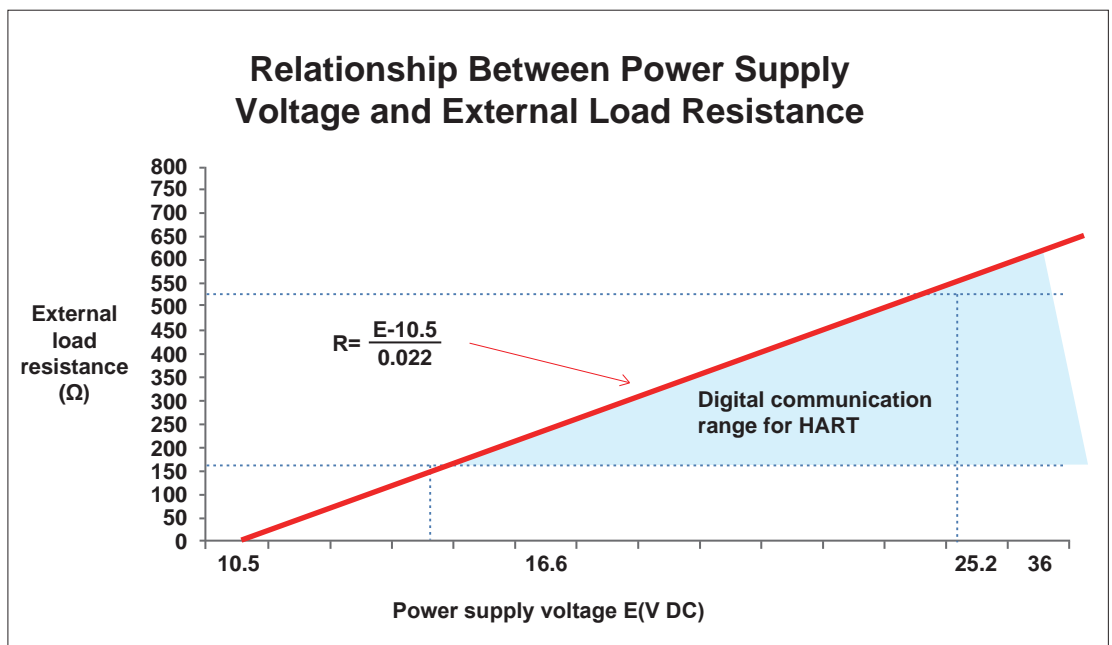

Supply and Load Requirements

24 VDC supply, $R \leq (U_s - 12 \text{ V}) / I_{\text{max}}$ kΩ, $I_{\text{max}} = 23 \text{ mA}$.

Maximum voltage limited: 42 VDC

Minimum Voltage limited: 12 VDC without LCD display

Minimum Voltage limited: 15 VDC with LCD display

250 Ω to 600 Ω for digital communication

Electrical Protection

Short-circuit protection is permanent.

Reverse polarity protection is not damage, but also is no function.

Electrical Connection

The electrical connection is made via cable entry M20x1.5.

The screw terminals are suitable for wire cross-sections up to 2.5 mm².

Standard Specifications

Process Connection

Flange with fixing thread 7/16-20 UNF and 1/4-18 NPT female thread on both sides.

Electromagnetic field

Meets all the requirements of EN 61326 and NAMUR NE-21.

Load

Within load/voltage specified limits the total effect is negligible.

Install

The transmitter housing can be rotated about 360 degrees relative to the transmitter module without affecting the performance and internal wiring.

Transmitter can be operated Through the PC machine or notebook computer via HART modem.

HART modem can be connected in parallel to the signal circuit at arbitrary point.

The HART modem communicates with the transmitter through an AC signal superimposed on the 4~20 mA output signals. This modulation does not change in the mean values, so does not affect the measurement signal.

Physical Specifications

Sensor Body

Stainless steel 316SS

Process Connector Gasket

Viton (FKM)
Teflon (PTFE)

Isolating Diaphragm

Stainless steel 316L
Hastelloy C
Gold plated on 316L
Teflon Plated on 316L

Amplifier Housing

Aluminium with epoxy resin coat
Stainless steel 316

Nuts and Bolts

stainless steel 304 / 1.4301
Carbon steel galvanized (Static pressure 400 bar)

Mounting Bracket

Stainless steel 304 / 1.4301
Carbon steel galvanized

Process Connection

Female thread 1/4" - 18 NPT / fixing 7/16 UNF
Oval flange 1/2" NPT Female thread
Others

Conduit Connection

M20 x 1.5

Name plate and tag

Stainless steel 304

Weight

3.3 kg

Body Flange

Stainless steel 316 / 1.4401

Degrees of Protection

IP66/IP67

Fill fluid

Silicone oil / Fluorinated oil

CE conformity EMC directive

EN 61000-6-2:2005
EN 61000-6-4:2007/A1:2011

2" MOUNTING TYPE

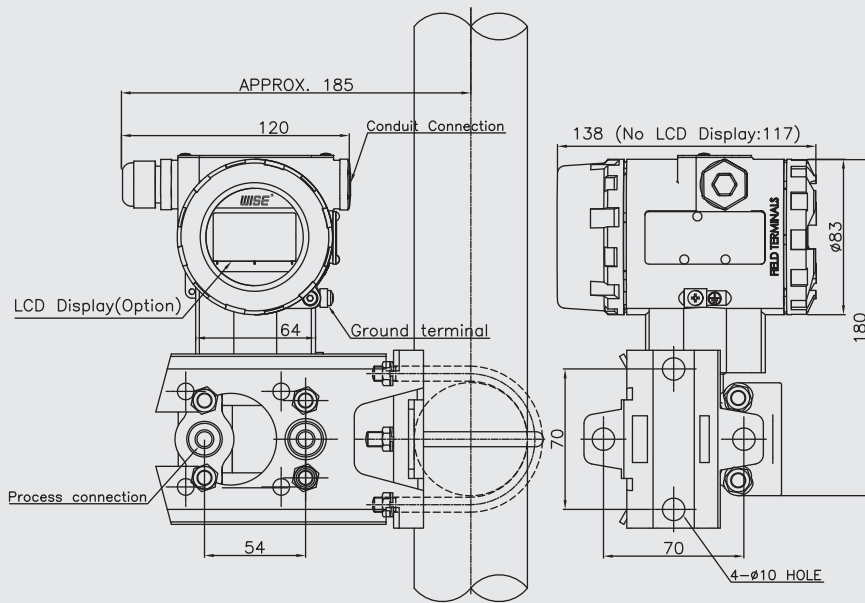

WALL MOUNTING TYPE

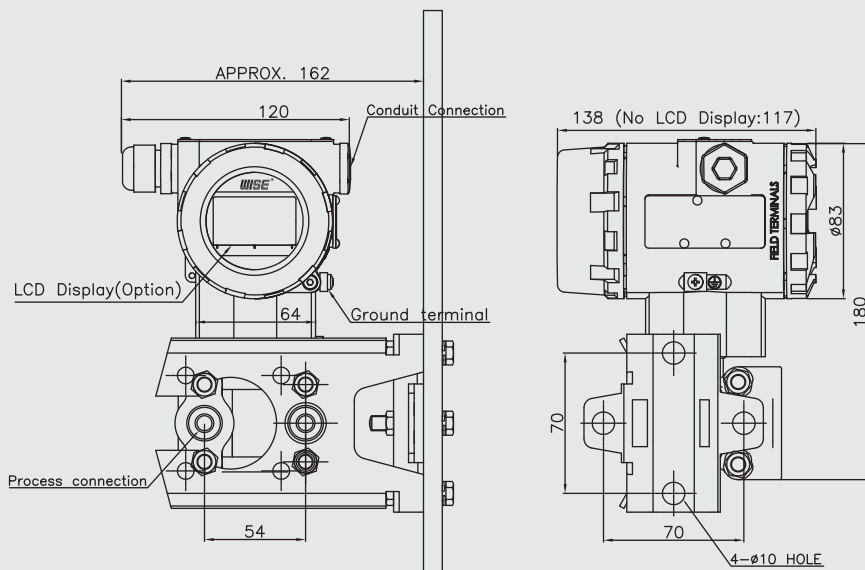

Electrical Connection Diagram

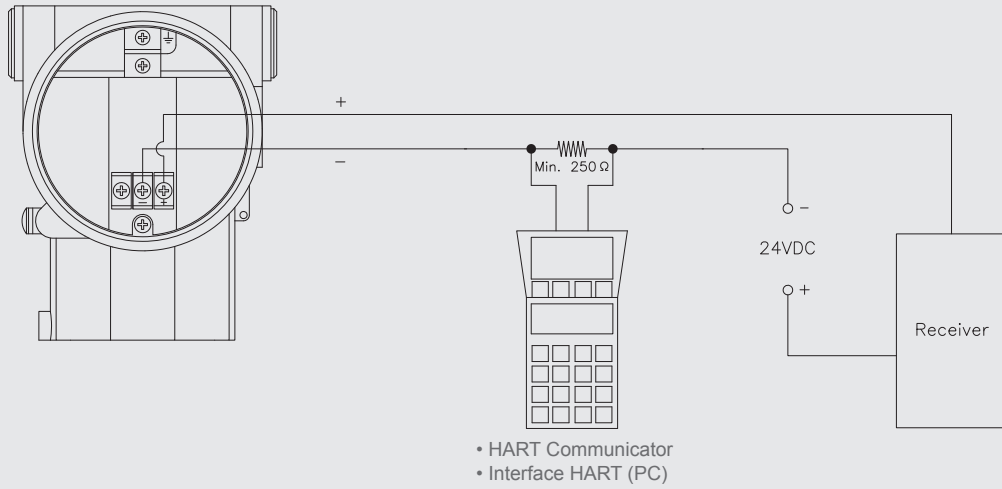

Terminal Configuration

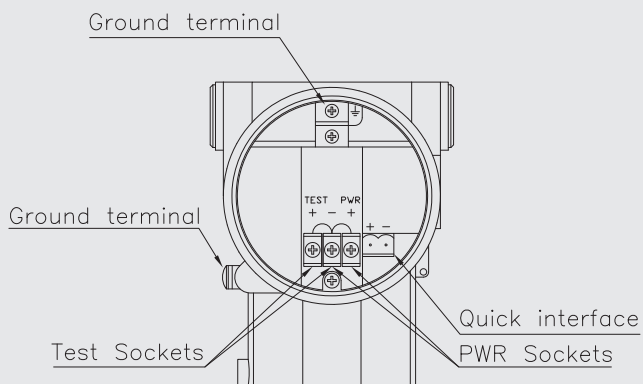

LCD Display

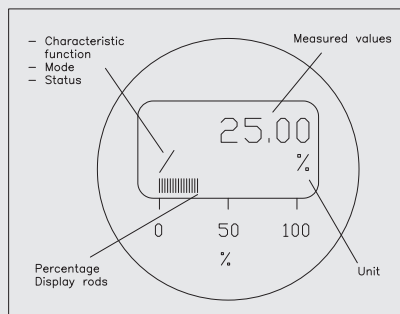

Process Connection Description

Oval-shaped flange with 1/4-18 NPT female thread (Option)

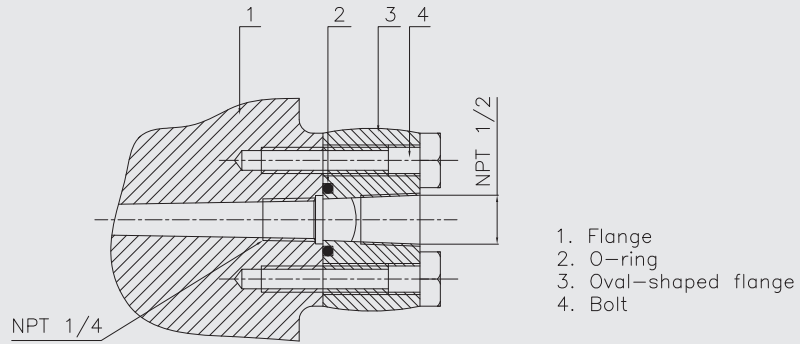

Local Set Button

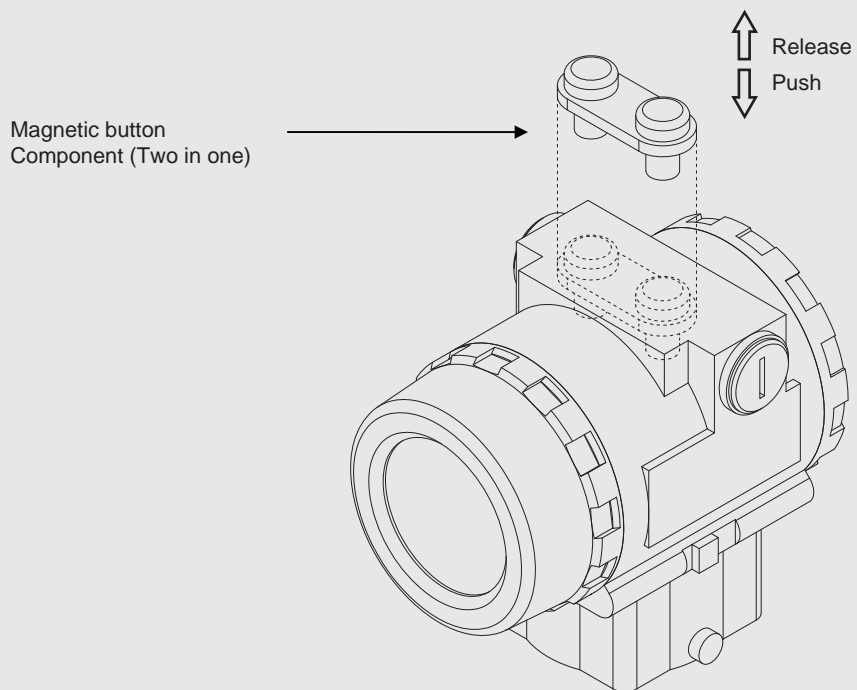

1. Base model

SMT2001 Differential Pressure Transmitter

2. Measuring Span

- A** 1 ~ 10 mbar (Only available accuracy 0.1 %)
- B** 2 ~ 60 mbar (Only available accuracy 0.075 %)
- C** 4 ~ 400 mbar
- D** 25 ~ 2,500 mbar
- E** 0.3 ~ 30 bar

3. Accuracy

- 5** 0.05 % (Only C~E Sensor)
- 7** 0.075 % (Only B~E Sensor)
- 1** 0.1 % (Only A Sensor)

4. Wetted parted materials (Seal diaphragm/Sensor Body)

- L** 316L SS / 316SS
- H** Hastelloy C-276 / 316SS
- T** 316L SS with Teflon Plated / 316SS
- G** 316L SS with Gold Plated / 316SS

5. Indication

- N** None
- D** Display (LCD)

6. Filled by fluid

- S** Silicone oil
- F** Fluorinated oil

7. Explosion protection

- N** None
- A** Ex ia (ATEX)
- B** Ex ia (IECEX)
- D** Ex d (ATEX)
- E** Ex d (IECEX)
- F** Ex d (KCS)

8. Housing material

- A** Aluminium
- S** 316SS

9. Mounting bracket material

- 5** Carbon steel galvanized
- 4** 304SS
- 0** None
- 9** Other

10. Process connection

- Q** Female thread 1/4" - 18" NPT (Fixing 7/16" UNF)
- F** Female thread 1/2" NPT with Oval Flange

11*. Accessory

- N** None
- V** Manifold Valve
- O** Other

* Note : Refer to A080's Specification and order valve(A080) separately. It's separate option.

12. Static pressure

- 7** 70 bar (Only measuring span A)
- 6** 160 bar
- 2** 250 bar
- 4** 400 bar (Bolt / Nut : Carbon steel)

13. Flange gasket

- V** Viton
- T** Teflon

14. Conduit connection (Ex-Proof)

- 3** NPT 1/2"
- 6** NPT 3/4"
- 8** M20X1.5P

15. Option

- 0** None
- 1** Plug_Ni Plated Brass
- 2** Plug_Stainless Steel
- 3** Cable Gland_Brass with Ni Plated
- 4** Cable Gland_Stainless Steel

1	2	3	4	5	6	7	8	9	10	11
SMT2001	A	5	L	N	S	N	A	5	Q	N
12	13	14	15	Sample ordering code						
7	V	5	1							