

OPTISWITCH 3000 series Vibration level switch

for solids

- Highly robust tuning fork
- Insensitive to build-up
- Set-up without filling
- Detection of solids in water
- Maintenance-free



Electromagnetic flowmeters

Variable area flowmeters

Mass flowmeters

Ultrasonic flowmeters

Vortex flowmeters

Flow controllers

Level measuring instruments

Pressure and temperature

Heat metering

Communications technology

Switches, counters, displays and recorders

Engineering systems & solutions

Contents

1 Description of the measuring principle	3
2 Type overview	5
3 Mounting instructions	7
4 Electrical connection	
4.1 Preparing the connection	9
4.2 Wiring plan	9
5 Operation	
5.1 Adjustment, general	11
5.2 Recurring function test - NAMUR electronics	11
5.3 Recurring function test - Two-wire electronics	11
6 Technical data	13
7 Dimensions	18

Take note of safety instructions for Ex applications



Please note the Ex specific safety information which you will find on our homepage www.krohne-mar.com and which come with the appropriate instrument. In hazardous areas you should take note of the appropriate regulations, conformity and type approval certificates of the sensors and power supply units. The sensors must only be operated on intrinsically safe circuits. The permissible electrical values are stated in the certificate.

1 Description of the measuring principle

Measuring principle

OPTISWITCH is a level sensor with tuning fork for level detection.

It is designed for industrial use in all areas of process technology and is preferably used for bulk solids.

The vibrating element (tuning fork) is energized piezoelectrically and vibrates at its mechanical resonance frequency. The piezos are fixed mechanically and are hence not subject to temperature shock limitations. If the vibrating element is submerged in the product, the vibrating amplitude changes. This change is detected by the integrated oscillator and converted into a switching command.

Typical applications are overflow and dry run protection. Thanks to its simple and robust measuring system, OPTISWITCH is virtually unaffected by the chemical and physical properties of the bulk solid.

It functions even when exposed to strong external vibration or changing products.

Fault monitoring

The electronics of OPTISWITCH continuously monitors the following criteria:

- Correct vibrating frequency
- Line break to the piezo drive

If one of the stated malfunctions is detected or in case of power failure, the electronics takes on a defined switching condition, e.g. the relay deenergises (safe condition).

Solid detection in water

With the OPTISWITCH (3100 C, 3200 C, 3300 C) version for solid detection in water (option), the vibrating element is adjusted to the density of water. If submerged in water (density 1 g/cm^3), OPTISWITCH signals "uncovered". Only if the vibrating element is also covered with solids (e.g. sand, sludge, etc.) will the sensor signal "covered".

OPTISWITCH 3100 C, 3200 C, 3300 C

OPTISWITCH3100 C, 3200 C and 3300 C level switches are available in standard, cable and tube version and, thanks to the large array of process fittings, offer the optimal solution for any application. They are completely manufactured of stainless steel and have all standard approvals.

OPTISWITCH are virtually unaffected by product properties and must hence not be adjusted.

The level switches can be used in applications with process temperatures up to $250 \text{ }^\circ\text{C}$ ($482 \text{ }^\circ\text{F}$) and pressures of up to 16 bar (232 psi).

You can detect bulk solids up to $>0.008 \text{ g/cm}^3$ (0.0003 lbs/in^3).

OPTISWITCH 3000 C

OPTISWITCH 3000 C differs from the OPTISWITCH 3100 C, 3200 C and 3300 C level switches in its simple process fitting of plastic and the limited selection options. It is suitable for bulk solids from $>0.08 \text{ g/cm}^3$ (0.003 lbs/in^3).

OPTISWITCH 3000 C is only available as screwed version with plastic housing and without approvals.

The most important advantage of this instrument is its price, which makes the measurement loop very cost-effective.

1.1 Application examples

Plastic processing



Fig. 1: Level detection in a silo storing plastic granules

A large number of finished products are produced in the chemical industry as powder, granules or pellets. Plastic granules and powder are often stored in high narrow silos which are filled pneumatically.

Vibrating level switches like OPTISWITCH have proven over the past years in the level detection of plastics. Even with smallest bulk densities of only 20 g/l and changing products, the instruments deliver always precise results.

Advantages:

- Tuning fork suitable down to a density $<20 \text{ g/l}$ (e.g. Aerosils)
- Product-independent switching point
- Setup without filling

Building material industry

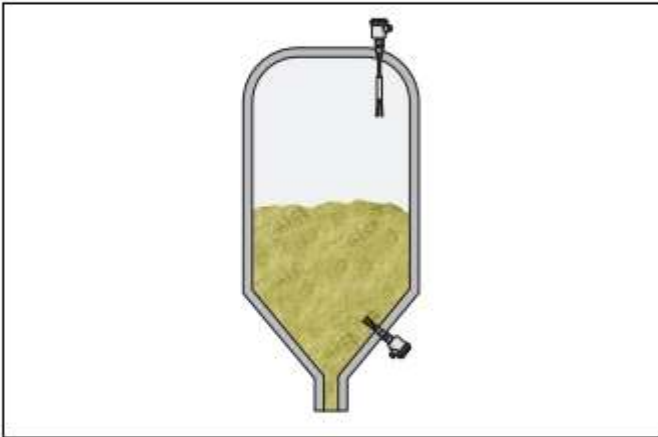

Fig. 2: Silo for aggregate in the building material industry

Cement or aggregates are placed in interim storage in multiple chamber silos. When the chambers are filled, large quantities of dust are generated. Depending on the consistency of the aggregate, different material cones are formed and the product properties can change from filling to filling.

OPTISWITCH offers additional protection against overfilling the aggregate silo. The flexible suspension cable avoids mechanical strain caused by movements of the bulk solid. A filling is not necessary for setup. Because OPTISWITCH has practically no moving parts, it is not subject to wear.

Advantages:

- very rugged tuning fork
- High abrasion resistance
- insensitive to buildup
- Setup without filling

2 Type overview

OPTISWITCH 3100 C



OPTISWITCH 3200 C



OPTISWITCH 3300 C



Preferred application:	Solids	Solids	Solids
Length:	-	0.3 ... 80 m (1 ... 262 ft)	0.3 ... 6 m (1 ... 20 ft)
Process fitting:	Thread G1½A, flanges	Thread G1½A, flanges	Thread G1½A, flanges
Process temperature:	-50 ... +150 °C (-58 ... +302 °F) -50 ... +250 °C (-58 ... +482 °F) with temperature adapter	-20 ... +80 °C (-4 ... +176 °F)	-50 ... +150 °C (-58 ... +302 °F) -50 ... +250 °C (-58 ... +482 °F) with temperature adapter
Process pressure:	-1 ... 16 bar/-100 ... 1600 kPa (-14.5 ... 232 psi)	-1 ... 6 bar/-100 ... 600 kPa (-14.5 ... 87 psi)	-1 ... 16 bar/-100 ... 1600 kPa (-14.5 ... 232 psi)
Signal output:	Relay, transistor, two-wire output, contactless electronic switch	Relay, transistor, two-wire output, contactless electronic switch	Relay, transistor, two-wire output, contactless electronic switch
Ruggedness	++	++	++
Sensitivity	++	++	++
Bulldup	++	++	++
Installation length	+	+	+

OPTISWITCH 3000 C



Preferred application:	Solids
Length:	-
Process fitting:	Thread G1½A
Process temperature:	-50 ... +100 °C (-58 ... +212 °F)
Process pressure:	-1 ... 6 bar/-100 ... 600 kPa (-14.5 ... 232 psi)
Signal output:	Relay, transistor, two-wire output, contactless electronic switch
Ruggedness	+
Sensitivity	-
Bulldup	++
Installation length	+

Housing

Plastic



Stainless steel



Aluminium

Electronics

Relay output



Transistor output



Contactless electronic switch



Two-wire output



NAMUR output

Sensors

Tuning fork

Approvals

Gas explosion protection



Dust explosion protection

3 Mounting instructions

Switching point

In general, OPTISWITCH can be mounted in any position. The instrument must be mounted in such a way that the vibrating element is at the height of the requested switching point.

The only exception is the mounting of the tuning fork vertically from the bottom. In this position it can happen that product sticks between the fork tines.

Socket

The vibrating element should protrude into the vessel to avoid buildup. For that reason, avoid using mounting bosses for flanges and screwed fittings. This applies particularly for horizontal installation and with adhesive products.

Filling opening

Install the instrument in such a way that the vibrating element does not protrude directly into the filling stream. Should such an installation location be necessary, mount a suitable baffle above or in front of the vibrating element, e.g. L80x8 DIN 1028 (see Fig. Part "a."). In abrasive solids, mounting according to fig. Part "b." has proven to be a good solution. The mound that forms in the concave baffle protects it from abrasion.

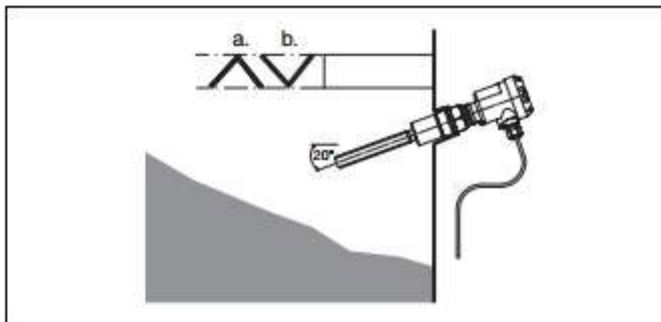

Fig. 3: Horizontal installation

- a. Convex mounting
- b. Concave mounting

Inflowing medium

If OPTISWITCH is mounted in the filling stream, unwanted switching signals may be generated. Mount OPTISWITCH at a location in the vessel where no disturbing influence from e.g. filling openings, agitators etc. can occur.

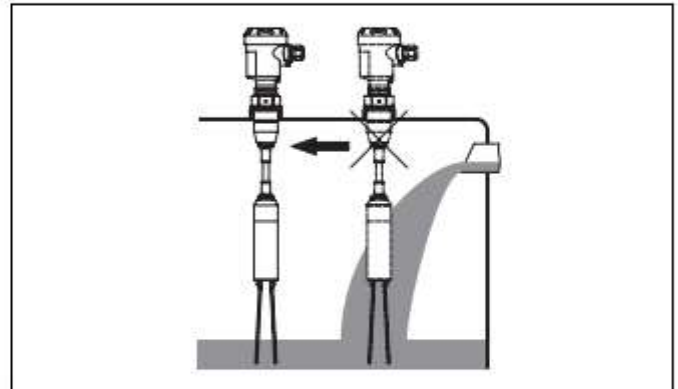

Fig. 4: Inflowing medium

Horizontal installation

To achieve a very precise switching point, you can install OPTISWITCH horizontally. However, if the switching point can have a tolerance of a few centimeters, we recommend mounting OPTISWITCH approx. 20° inclined to the vessel bottom to avoid buildup.

Turn the tuning fork of OPTISWITCH 3000 in such a way that no product is left on the fork surface. To direct the fork, there is a marking on the hexagon of the thread. Make sure that the marking points upward.

Material cone

In silos containing solids, material cones can form which change the switching point. Please keep this in mind when installing the sensor in the vessel. We recommend selecting an installation location where the vibrating element detects an average value of the material cone.

The vibrating element must be mounted at a location that takes the arrangement of the filling and emptying apertures into account.

To compensate measurement errors caused by the material cone in cylindrical vessels, the sensor must be mounted at a distance of $d/6$ from the vessel wall.

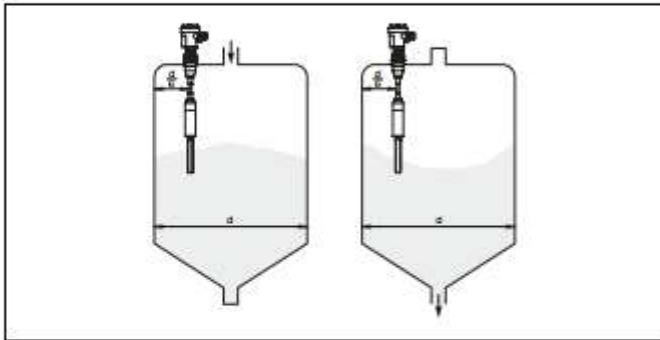

Fig. 5: Filling and emptying centered

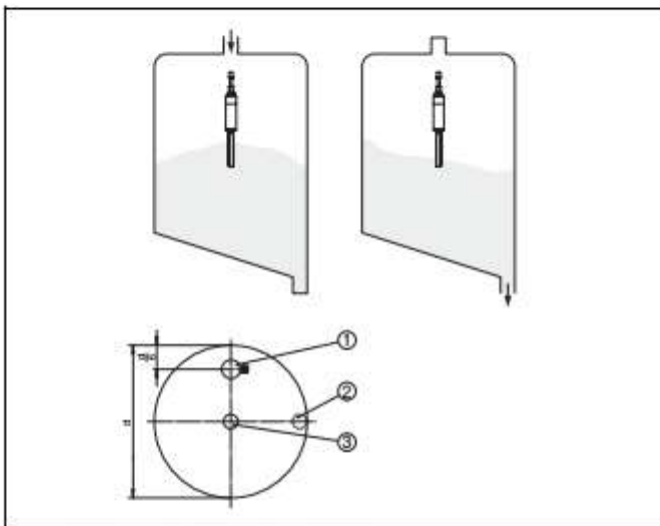

Fig. 6: Filling in the center, emptying laterally

- 1 OPTISWITCH
- 2 Emptying opening
- 3 Filling opening

Tensile load

With cable version, make sure that the max. permissible tensile load of the suspension cable is not exceeded. The danger of this happening exists particularly with very heavy solids and large meas. lengths. The max. permissible load is stated in chapter "Technical data".

Agitators

Filling or extraction forces, equipment vibration, or similar, can subject the level switch to strong lateral forces. For this reason, do not use an overly long extension tube for OPTISWITCH, but check if you can mount an OPTISWITCH 3000 C or 3100 C level switch on the side of the vessel in horizontal position.

Extreme vibration caused by the process or the equipment, e.g. by fluidization or beaters in the vessel, can cause the extension tube of OPTISWITCH to vibrate in resonance. This leads to increased stress on the upper weld joint. Should a longer tube version be necessary, you can provide a suitable support or guy directly above the vibrating element to secure the extension tube.



This measure applies particularly to applications in Ex areas. Make sure that the tube is not subjected to bending forces through this measure.

Should the installation from top be necessary, check if you can use a cable version.

In the long run, strong vibrations can damage the instrument electronics. With a remote housing these can be disconnected from the process.

Flows

To minimise flow resistance caused by the tuning fork, OPTISWITCH should be mounted in such a way that the surfaces of the blades are parallel to the product movement.



Fig. 7: Orientation of the tuning fork in case of flow

- 1 Marking with screwed version
- 2 Direction of flow

Lock fitting

OPTISWITCH in tube version can be mounted with a lock fitting for height adjustment. Take note of the pressure specifications of the lock fitting.

Baffle protection against falling rocks

In applications such as grit chambers or settling basins for coarse sediments, the vibrating element must be protected against damage with a suitable baffle.

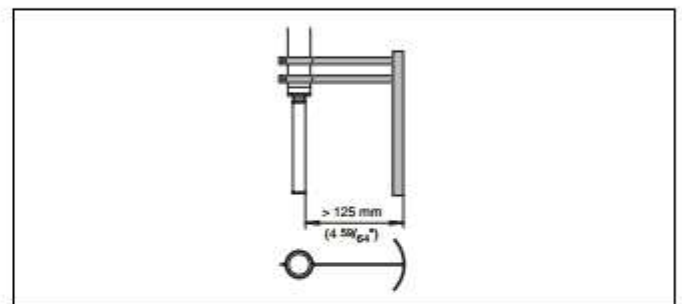

Fig. 8: Baffle protection against damages

Pressure/Vacuum

The process fitting must be sealed if there is gauge or low pressure in the vessel. Check if the seal material is resistant against the measured product and the process temperature.

4 Electrical connection

4.1 Preparing the connection

Note safety instructions

Generally note the following safety instructions:

- Connect only in the complete absence of line voltage

Take note of safety instructions for Ex applications



In hazardous areas you should take note of the appropriate regulations, conformity and type approval certificates of the sensors and power supply units.

Select power supply

Connect the power supply according to the following diagrams. Oscillators with relay output and contactless electronic switch are designed in protection class 1. To maintain this protection class, it is absolutely necessary that the ground conductor be connected to the internal ground terminal. Take note of the general installation regulations. As a rule, connect OPTISWITCH to vessel ground (PA), or in case of plastic vessels, to the next ground potential. On the side of the housing there is a ground terminal between the cable entries. This connection serves to drain off electrostatic charges. In Ex applications, the installation regulations for hazardous areas must be given priority.

The data for power supply are stated in the "Technical data" in the "Supplement".

Selecting connection cable

The instrument is connected with standard cable with round cross section. An outer cable diameter of 5 ... 9 mm (0.2 ... 0.35 in) ensures the seal effect of the cable gland.

If cable with a different diameter or wire cross section is used, exchange the seal or use an appropriate cable connection.



In hazardous areas, only use approved cable connections for OPTISWITCH.

Select connection cable for Ex applications



Take note of the corresponding installation regulations for Ex applications.

4.2 Wiring plan

Relay output

We recommend connecting OPTISWITCH in such a way that the switching circuit is open when there is a level signal, line break or failure (safe condition).

The relays are always shown in non-operative condition.

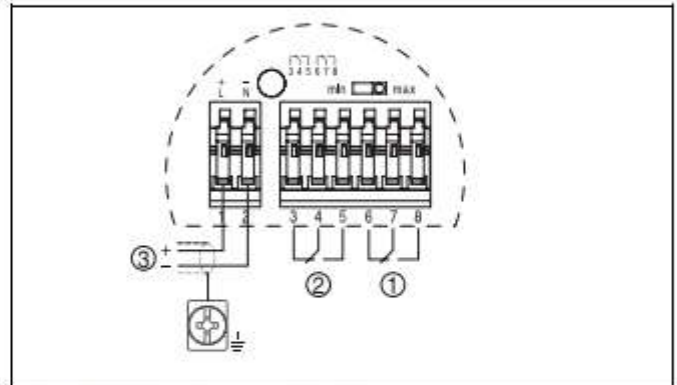

Fig. 9: Wiring plan, single chamber housing

- 1 Relay output
- 2 Relay output
- 3 Voltage supply

Transistor output

We recommend connecting OPTISWITCH in such a way that the switching circuit is open when there is a level signal, line break or failure (safe condition).

The instrument is used to control relays, contactors, magnet valves, warning lights, horns as well as PLC inputs.

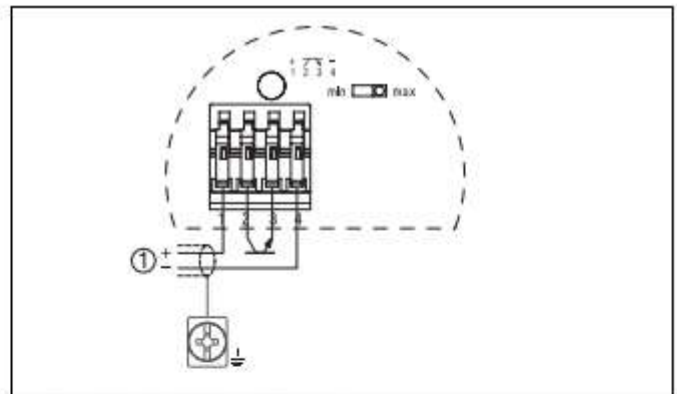

Fig. 10: Wiring plan, single chamber housing

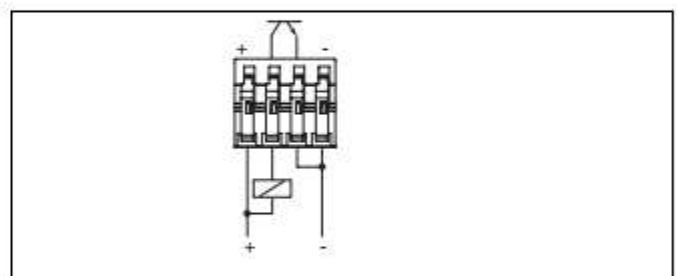

Fig. 11: NPN action

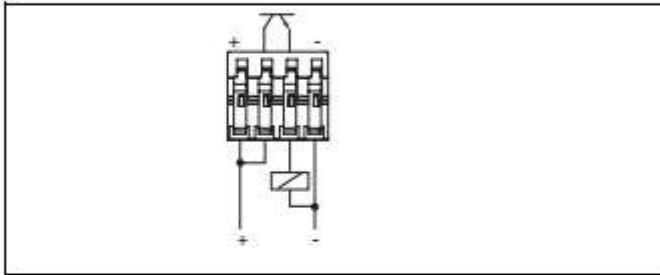

Fig. 12: PNP action

Contactless electronic switch

We recommend connecting OPTISWITCH in such a way that the switching circuit is open when there is a level signal, line break or failure (safe condition).

The contactless electronic switch is always shown in non-operative condition.

The instrument is used for direct control of relays, contactors, magnet valves, warning lights, horns etc. It must not be operated without an intermediately connected load, because the electronics would be destroyed if connected directly to the mains. It is not suitable for connection to low voltage PLC inputs.

Domestic current is temporarily lowered below 1 mA after switching off the load so that contactors, whose holding current is lower than the constant domestic current of the electronics, are reliably switched off.

When OPTISWITCH is used as part of an overfill protection system according to WHG, also note the regulations of the general type approval.

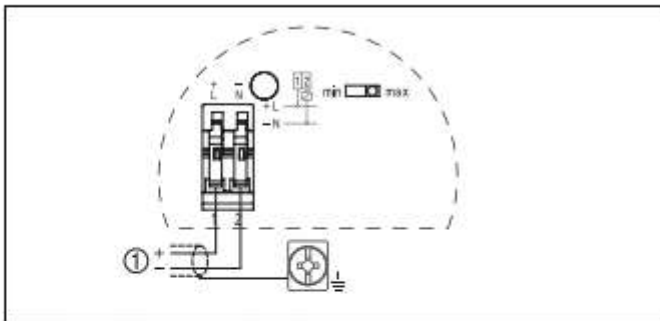

Fig. 13: Wiring plan, single chamber housing

1 Screening

Two-wire output

We recommend connecting OPTISWITCH in such a way that the switching circuit is open when there is a level signal, line break or failure (safe condition).

For connection to an SU 501 signal conditioning instrument dto. Ex. The sensor is powered by the connected signal conditioning instrument. Further information is available in chapter "Technical data" in the "Supplement", "Ex-technical data" are available in the supplied "Safety information manual".

Take note of the operating instructions manual of the signal conditioning instrument. Suitable signal conditioning instruments are listed in chapter "Technical data".

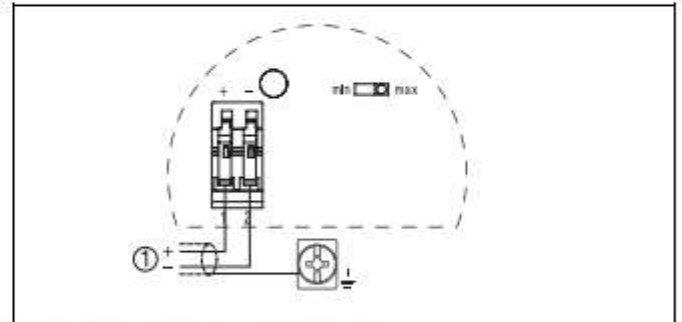

Fig. 14: Wiring plan, single chamber housing

1 Voltage supply

NAMUR output

For connection to an amplifier according to NAMUR (IEC 60947-5-6, EN 50227). For further information see chapter "Technical data".

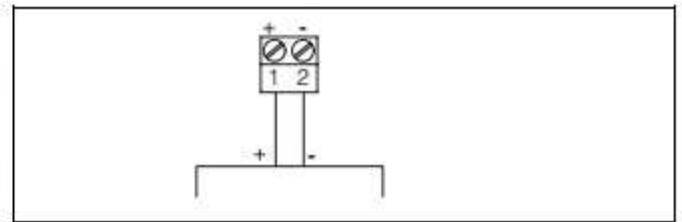

Fig. 15: Wiring plan, single chamber housing

5 Operation

5.1 Adjustment, general

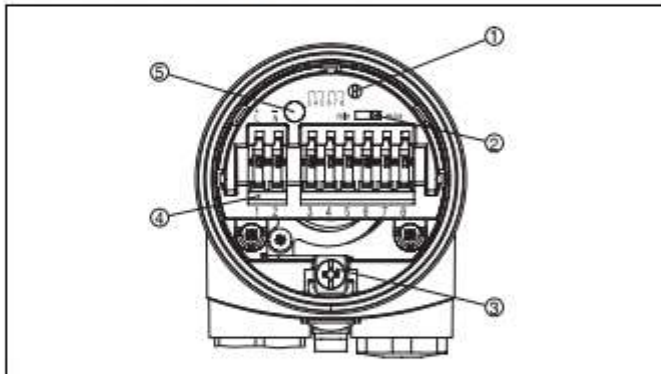

Fig. 16: Adjustment elements electronics module, e.g. relay output (VB60R)

- 1 Potentiometer for switching point adaptation (not with OPTISWITCH 3000 C)
- 2 DIL switch for mode adjustment
- 3 Ground terminal
- 4 Screwed terminals
- 5 Control lamp

Switching point adaptation (1)

OPTISWITCH 3100 C, 3200 C, 3300 C

You can adapt the switching point of OPTISWITCH to the solid with the potentiometer. The switching point is preset and covered by a label. It must only be modified in special cases.

OPTISWITCHs with tuning fork are preset to a product density of $>0.02 \text{ g/cm}^3$ (0.0007 lbs/in^3). In very light solids, turn the potentiometer to complete left position $0.008 \dots 0.1 \text{ g/cm}^3$ ($0.0003 \dots 0.0036 \text{ lbs/in}^3$). By doing this, the tuning fork will be more sensitive and can detect very light solids, such as e.g. Aerosils more reliably.

OPTISWITCH 3000 C

OPTISWITCH 3000 C can detect bulk solids from a product density of $>0.08 \text{ g/cm}^3$ (0.003 lbs/in^3).

Mode adjustment (2)

With the mode adjustment (min./max.) you can change the switching condition of the output. You can set the required mode (max. - max. detection or overflow protection, min. - min. detection or dry run protection).

Signal lamp (5)

Diode for indication of the switching status.

5.2 Recurring function test - NAMUR electronics

According to IEC 61508.

SIL

OPTISWITCH is qualified in mode A (overflow protection) for use in measuring chains of stage SIL2 according to IEC 61508 (redundant, stage SIL3).

You find the "Safety Manual" with detailed specification on SIL on our website.

Recurring function test

The recurring test according to IEC 61508 can be carried out by pushing the simulation key on the oscillator or by briefly (>2 seconds) interrupting the supply to the sensor. The correct sequence of the switching conditions must be monitored via the switching amplifier as well as the connected systems. The sensor must neither be removed nor a response triggered by filling the vessel.

Simulation key on the electronics module

OPTISWITCH has an integrated simulation key. The simulation key is lowered on the electronics module. Push the simulation key for >2 seconds.

If OPTISWITCH is connected to an SPLC, you have to interrupt the connection cable to the sensor for >2 seconds.

After releasing the simulation key or briefly interrupting the connection cable to the sensor, you can check the complete measuring system on correct function. A switching procedure is simulated during the test.

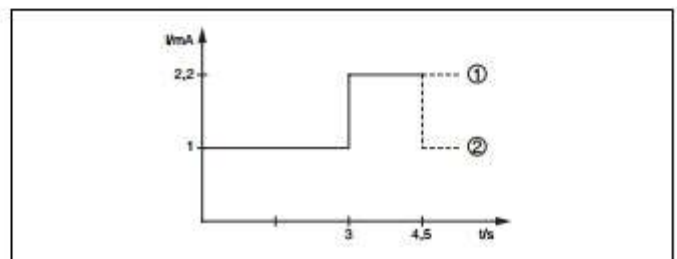

Fig. 17: Flow chart of the function test

- 1 Full signal
- 2 Empty signal

Check if all the switching conditions occur in the correct sequence and the stated time period. If this is not the case, there is a fault in the measuring system. Keep in mind that connected instruments are activated during the function test. This allows you to check the correct function of the measuring system.

5.3 Recurring function test - Two-wire electronics

According to IEC 61508.

SIL

OPTISWITCH in conjunction with a suitable signal conditioning instruments is qualified in mode A (overflow protection) for use in measuring chains of stage SIL2 according to IEC 61508 (redundant, stage SIL3).

You find the "Safety Manual" with detailed specification on SIL on our website.

Recurring function test

The recurring test according to IEC 61508 can be carried out by pushing the test key on the signal conditioning instrument or by briefly (>2 seconds) interrupting the supply to the sensor. The correct sequence of the switching conditions must be monitored via the two LEDs on the signal conditioning instrument as well as the connected systems. The sensor must neither be removed nor a response triggered by filling the vessel.

You can carry out the function test with the outputted current values also directly via a safety PLC or a process control system. The implementation and switching sequence of the function test is described also in the operating instructions manual of the appropriate signal conditioning instrument.

Test key on the signal conditioning instrument

The signal conditioning instrument has an integrated test key. The test key is lowered in the front plate of the signal conditioning instrument. Push the test key with a suitable object (e.g. screwdriver, pen etc.) for >2 seconds.

If OPTISWITCH is connected to an SPLC, you have to interrupt the connection cable to the sensor for >2 seconds.

After releasing the test key or interrupting the connection cable to the sensor, the complete measuring system can be checked on correct function. The following operating conditions are simulated during the test:

- Fault signal
- Empty signal
- Full signal

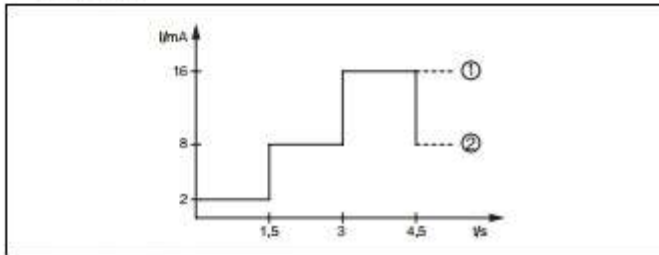

Fig. 18: Flow chart of the function test

- 1 Full signal
- 2 Empty signal

Check if all the switching conditions occur in the correct sequence and the stated time period. If this is not the case, there is a fault in the measuring system. Keep in mind that connected instruments are activated during the function test. This allows you to check the correct function of the measuring system.

6 Technical data

General data

Material 316L corresponds to 1.4404 or 1.4435

OPTISWITCH 3000 C

Materials, wetted parts

- Process fitting - thread
- vibrating element

PBT

316L/318S13 (1.4462)

Materials, non-wetted parts

- Housing
- Seal ring between housing and housing cover
- Ground terminal

plastic PBT (Polyester)

Silicone

316Ti/316L

Weight

1150 g (40 oz)

Max. lateral load

600 N (135 lbf)

OPTISWITCH 3100 C

Materials, wetted parts

- Process fitting - thread
- Process fitting - flange
- Seal
- vibrating element
- Extension tube (OPTISWITCH 3300 C) \varnothing 43 mm (1.7 in)

316L

316L

Klingsersil C-4400

316L

316L

Materials, non-wetted parts

- Housing
- Seal ring between housing and housing cover
- Ground terminal

Plastic PBT (Polyester), Alu die-casting powder-coated, 316L

NBR (stainless steel housing), silicone (Alu/plastic housing)

316Ti/316L

Weights

- OPTISWITCH 3100 C with plastic housing
- OPTISWITCH 3100 C with Aluminium housing
- OPTISWITCH 3100 C with stainless steel housing

1500 g (53 oz)

1950 g (69 oz)

2300 g (81 oz)

Max. lateral load

600 N (135 lbf)

OPTISWITCH 3200 C

Materials, wetted parts

- Process fitting - thread
- Process fitting - flange
- Seal
- vibrating element
- Suspension cable

316L

316L

CR, CSM

316L

PUR

Materials, non-wetted parts

- Housing
- Seal ring between housing and housing cover
- Ground terminal

Plastic PBT (Polyester), Alu die-casting powder-coated, 316L

NBR (stainless steel housing), silicone (Alu/plastic housing)

316Ti/316L

Weights

- OPTISWITCH 3200 C with plastic housing
- OPTISWITCH 3200 C with Aluminium housing
- OPTISWITCH 3200 C with stainless steel
- Suspension cable

1500 g (53 oz)

1950 g (69 oz)

2300 g (81 oz)

Max. permissible tensile load

approx. 165 g/m (1.8 oz/ft)

3000 N (675 lbs)

Sensor length

0,3 ... 80 m (1 ... 262 ft)

OPTISWITCH 3300 C

Materials, wetted parts

- Process fitting - thread
- Process fitting - flange
- Seal
- vibrating element
- Extension tube (OPTISWITCH 3300 C) \varnothing 43 mm (1.7 in)

316L

316L

Klingsersil C-4400

316L

316L

Materials, non-wetted parts

- Housing
- Seal ring between housing and housing cover
- Ground terminal

Plastic PBT (Polyester), Alu die-casting powder-coated, 316L

NBR (stainless steel housing), silicone (Alu/plastic housing)

316Ti/316L

Weights

- OPTISWITCH 3300 C with plastic housing	1500 g (53 oz)
- OPTISWITCH 3300 C with Aluminium housing	1950 g (69 oz)
- OPTISWITCH 3300 C with stainless steel housing	2300 g (81 oz)
- Extension tube (OPTISWITCH 3300 C) ø 43 mm (1.7 in)	approx. 2000 g/m (21.5 oz/ft)
Sensor length	0.3 ... 6 m (1 ... 20 ft)
Max. lateral load	290 Nm (214 lbf ft), max. 600 N (135 lbf)
Max. lateral load	
- OPTISWITCH 3300 C	290 Nm (214 lbf ft), max. 600 N (135 lbf)

Output variable

Relay output

Output	relay output (DPDT), 2 floating spdts
Turn-on voltage	
- min.	10 mV
- max.	253 V AC, 253 V DC
Switching current	
- min.	10 µA
- max.	5 A AC, 1 A DC
Breaking capacity	
- max.	1250 VA, 50 W
Contact material (relay contacts)	AgCdO and Au plated
Modes (adjustable)	min./max.
Delay time	
- when immersed	approx. 0.5 s
- when laid bare	approx. 1 s

Transistor output

Output	floating transistor output, overload and permanently shortcircuit proof
Load current	max. 400 mA
Turn-on voltage	max. 55 V DC
Blocking current	<100 µA
Modes (adjustable)	min./max.
Delay time	
- when immersed	approx. 0.5 s
- when laid bare	approx. 1 s

Contactless electronic switch

Output	Contactless electronic switch
Modes (adjustable)	min./max.
Delay time	
- when immersed	approx. 0.5 s
- when laid bare	approx. 1 s

Two-wire output

Output	Two-wire output
Suitable signal conditioning instruments	SU 501
Output signal	
- Mode min.	Vibrating element uncovered: 16 mA ± 1 mA, vibrating element covered: 8 mA ± 1 mA
- Mode max.	Vibrating element uncovered: 8 mA ± 1 mA, vibrating element covered: 16 mA ± 1 mA
- Fault signal	<2 mA
Modes (adjustable)	min./max.
Delay time	
- when immersed	approx. 0.5 s
- when laid bare	approx. 1 s

NAMUR output

Output	Two-wire NAMUR output
--------	-----------------------

Current consumption	
- Falling characteristics (max.)	≥2.2 mA uncovered/≤1 mA covered
- Rising characteristics (min.)	≤1 mA uncovered/≥2.2 mA covered
- Fault signal	≤1 mA
Necessary processing system	NAMUR processing system according to IEC 60947-5-6 (EN 50227/ DIN 19234)
Modes (NAMUR output adjustable to falling or rising characteristics)	
- min.	rising characteristics (High current when immersed)
- max.	falling characteristics (Low current when immersed)

Ambient conditions

Ambient temperature on the housing	-40 ... +70 °C (-40 ... +158 °F)
Storage and transport temperature	-40 ... +80 °C (-40 ... +176 °F)

Process conditions

OPTISWITCH 3000 C

Parameter	Limit level of solids
Process pressure	-1 ... 6 bar/-100 ... 600 kPa (-14.5 ... 87 psi) with PN 40
Process temperature OPTISWITCH of 316L	-50 ... 100 °C (-58 ... +212 °F)
Density	>0.08 g/cm ³ (0.003 lbs/in ³)
Granular size	ø max. 15 mm (0.6 in)

OPTISWITCH 3100 C, 3300 C

Parameter	Limit level of solids
Process pressure	-1 ... 25 bar/-100 ... 2500 kPa (-14.5 ... 363 psi) with PN 40
Process temperature OPTISWITCH of 316L	-50 ... 150 °C (-58 ... 302 °F)
Process temperature (thread or flange temperature) with temperature adapter (option)	-50 ... 250 °C (-58 ... 482 °F)

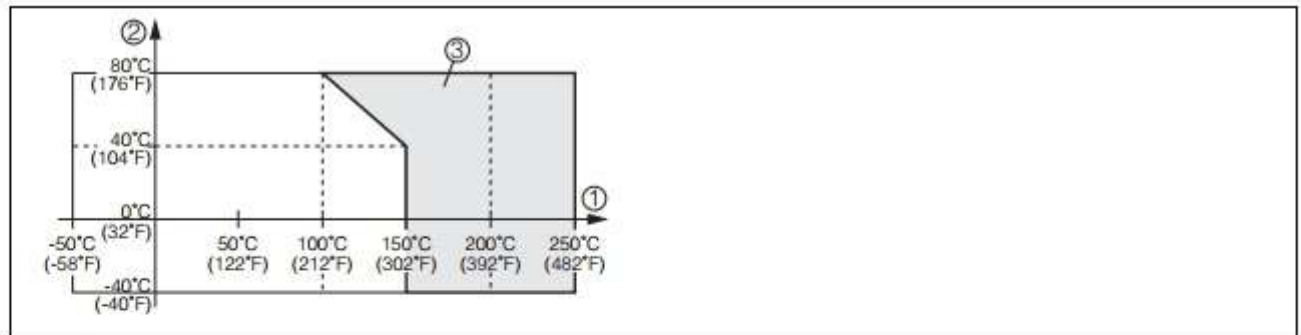

Fig. 19: Ambient temperature - Product temperature

- 1 Product temperature
- 2 Ambient temperature
- 3 Temperature range with temperature adapter

Density	>0.008 g/cm ³ (0.0003 lbs/in ³)
Granular size	ø max. 15 mm (0.6 in)

OPTISWITCH 3200 C

Parameter	Limit level of solids
Process pressure	-1 ... 6 bar/-100 ... 600 kPa (-14.5 ... 87 psi) with PN 40
Process temperature OPTISWITCH of 316L	-20 ... +80 °C (-4 ... +176 °F)
Density	>0.008 g/cm ³ (0.0003 lbs/in ³)
Granular size	ø max. 15 mm (0.6 in)

Electromechanical data

Cable entry/plug (dependent on the version)	
- Single chamber housing	• 1x cable entry M20x1.5 (cable-ø 5 ... 9 mm), 1x blind stopper M20x1.5; attached 1x cable entry M20x1.5

Spring-loaded terminals

or:

- 1x cable entry ½ NPT, 1x blind stopper ½ NPT, 1x cable entry ½ NPT

or:

- 1x plug M12x1, 1x blind stopper M20x1.5

for wire cross-section up to 1.5 mm²

Adjustment elements

Electronics versions - relay, transistor output, contactless electronic switch

Mode switch

- min.
- max.

Min. detection or dry run protection

Max. detection or overflow protection

Electronics version - two-wire output

Mode switch

- min.
- max.

Vibrating element uncovered: 16 mA ±1 mA
Vibrating element covered: 8 mA ±1 mAVibrating element uncovered: 8 mA ±1 mA
Vibrating element covered: 16 mA ±1 mA

Electronics version - NAMUR output

Mode switch

- min.
- max.

rising characteristics (High current when immersed)

falling characteristics (Low current when immersed)

Voltage supply

Relay output

Supply voltage

20 ... 253 V AC, 50/60 Hz, 20 ... 72 V DC (at U >60 V DC, the ambient temperature can be max. 50 °C/122 °F)

Power consumption

1 ... 8 VA (AC), approx. 1.3 W (DC)

Transistor output

Supply voltage

10 ... 55 V DC

Power consumption

max. 0.5 W

Contactless electronic switch

Supply voltage

20 ... 253 V AC, 50/60 Hz, 20 ... 253 V DC

Domestic current requirement

approx. 3 mA (via load circuit)

Load current

- min.
- max.

10 mA

400 mA (at I >300 mA the ambient temperature can be max. 60 °C/140 °F)
max. 4 A up to 40 ms

Two-wire output

Supply voltage

10 ... 36 V DC (via the signal conditioning instrument)

NAMUR output

Supply voltage (standard characteristics)

for connection to amplifier according to NAMUR IEC 60947-5-6, approx. 8.2 V

Open-circuit voltage

U_o approx. 8.2 V

Shortcircuit current

I_U approx. 8.2 mA

Electrical protective measures

Electronics versions - relay output, contactless electronic switch

Protection

IP 66/IP 67

Overvoltage category

III

Protection class

I

Electronics versions - Transistor, two-wire, NAMUR output

Protection

IP 66/IP 67

Overvoltage category

III

Protection class

II

Approvals**OPTISWITCH 3000 C**

OPTISWITCH 3000 C has no approvals.

OPTISWITCH 3100 C, 3200 C, 3300 C, electronics versions - relay output, transistor output, contactless electronic switch

ATEX II 1/2G, 2G EEx d IIC T6

ATEX II 1/2 D IP66 T

OPTISWITCH 3100 C, 3200 C, 3300 C, electronics version - two-wire output

ATEX II 1G, 1/2G, 2G EEx ia IIC T6

ATEX II 1G, 1/2G, 2G EEx ia IIC T6 + ATEX II 1/2 D IP66 T6

ATEX II 1/2G, 2G EEx d IIC T6

ATEX II 1/2 D IP66 T

CE conformity**Electronics versions - Relay, transistor, two-wire, NAMUR output**

EMVG (89/336/EWG), Emission: EN 61326: 1997 (class B),

Susceptibility: EN 61326: 1997/A1: 1998

NSR (73/23/EWG), EN 61010-1: 2001

Electronics version - contactless electronic switch

EMVG (89/336/EWG), Emission: EN 61326/A1: 1998 (class B),

Susceptibility: EN 61326: 1997/A1: 1998

NSR (73/23/EWG), EN 61010-1: 2001

SIL conformity

OPTISWITCH fulfills the requirements of functional safety according to IEC 61508. You can find further information in the "*Safety Manual OPTISWITCH*".

7 Dimensions

Housing

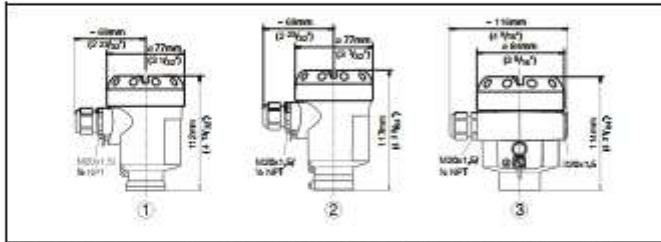

Fig. 20: Housing versions (OPTISWITCH 3000 C only with plastic housing)

- 1 Plastic housing
- 2 Stainless steel housing
- 3 Aluminium housing

OPTISWITCH 3000 C

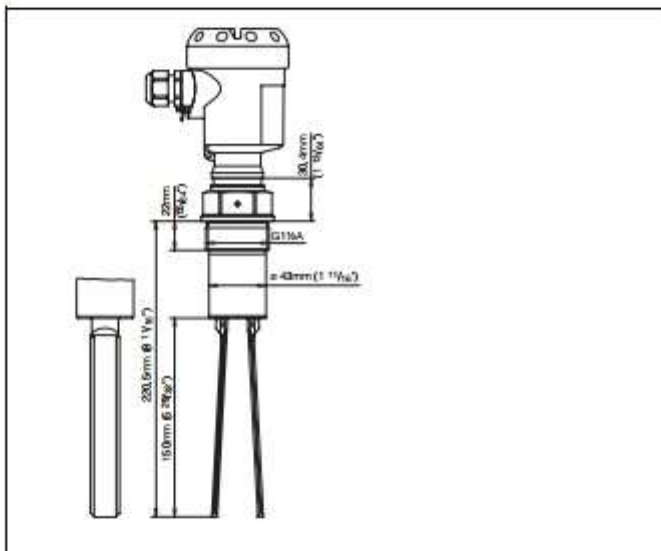
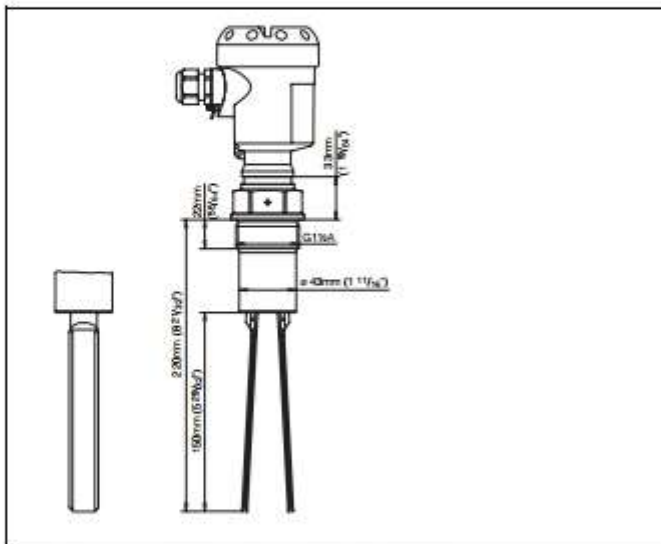

Fig. 21: OPTISWITCH 3000 C, threaded version G1½

OPTISWITCH 3100 C



OPTISWITCH 3300 C

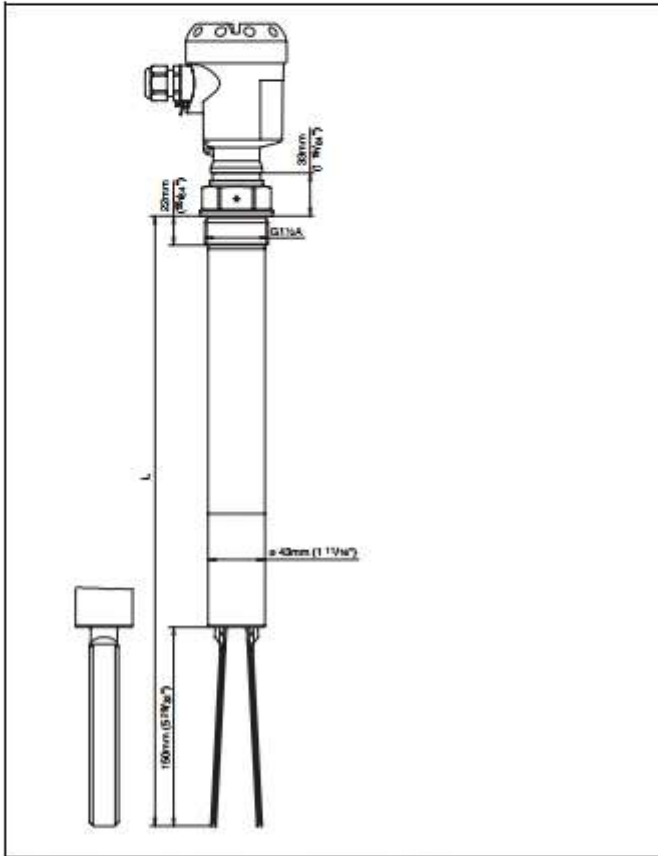

Fig. 24: OPTISWITCH 3300 C, threaded version G1½

Temperature adapter

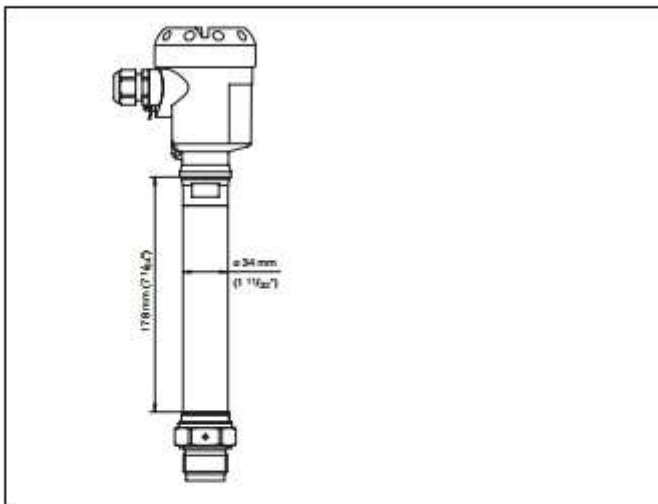

Fig. 25: Temperature adapter (only for OPTISWITCH 3100 C and 3200 C)