



## BM 26 F Technical Datasheet

### Bypass Chamber with integrated Guided Radar (TDR) Level Meter

- Ideal for tanks with obstructed environments
- Measures level, interface, and level and interface
- Optional remote housing provides the user with an unrestricted view of the display screen



## The solution for tanks with obstructed environments

BM 26 F is based on proven bypass measurement technology. It is capable of high precision measurement and is unaffected by foam, agitated product surface and obstructed tank environments. BM 26 F integrates the OPTIFLEX 1300 C Guided Radar (TDR) Level Meter for distance, level and volume measurement of liquids and liquid/liquid interface. It can also optionally indicate level using a permanent, IP68 local indication without power supply.

For pressures 40...120 bar / 580...1740 psig and temperatures 200...300°C / 390...570°F, we recommend using our BM 26A bypass level indicator. For pressures more than 120 bar / 1740 psig and temperatures higher than 300°C / 570°F, we recommend using our BW 25 displacer-type level indicator.

For further information on the integrated Guided Radar (TDR) level meter, please refer to the Technical Datasheet for the OPTIFLEX 1300 C.



- 1 2-wire guided-radar (TDR) level meter
- 2 Option: vent
- 3 Option: side or inline process connection at bottom of chamber
- 4 Option: drain
- 5 Option: magnetically-coupled level indicator
- 6 Accessory: limit switches

### Highlights

- Configured system - easy to measure
- Measurement independent of density
- Ideal for tanks with obstructed environments
- PACTware and DTMs included as standard
- Measures down to dielectric constant of 1.4
- Display in 9 languages: even in Chinese, Japanese and Russian
- Housing is removable under process conditions

### Industries

- Oil & Gas
- Petrochemicals
- Power
- Water

### Applications

- Process and storage tanks
- Steam crackers
- Boilers
- Separators

## Applications

### 1. Measurement of liquids in tanks with obstructed environments



If the tank is full of obstructions such as agitators and reinforcements, we recommend using the BM 26 F. It can also measure accurately in agitated conditions and in the presence of foam.

### 2. Remote display on high or inaccessible tanks

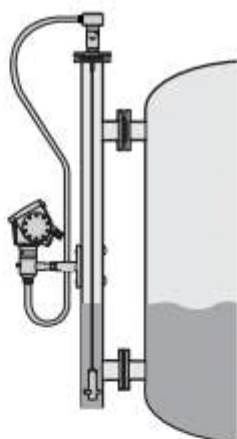

If it is difficult or impossible to read BM 26 F's integrated display at the top of the tank, KROHNE recommends the remote display option. It is provided with a cable up to 14.5 m / 47.5 ft. long and a bracket for mounting in an accessible position.

### 3. Autonomous local indication

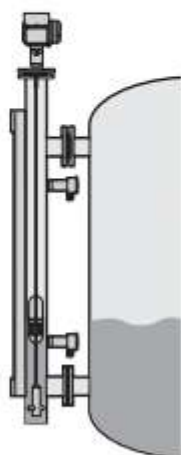

The BM 26 F has a float and indicating tube option for indicating level on a highly visible column of yellow/black rotating flaps. No power is needed. This option is not for the US market. It is also possible to fit limit switches, with optional Ex approval, if you choose the float system option.

## Technical Data: general information

	BM 26 F standard	BM 26 F with float system
--	------------------	---------------------------

### Input

Device	TDR level transmitter mounted on a bypass chamber	TDR level transmitter mounted on a bypass chamber with magnetic level indicator ❶
Function 1	Time Domain Reflectometry (TDR)	
Function 2	-	Float magnetically coupled to mechanical level indicator
Parameter	Level, distance, volume and/or interface	
Max. measuring range		
Single Rod probe Ø8 mm / 0.3"	0.8...4 m / 2.5...13 ft	
Single Cable probe Ø4 mm / 0.15"	4...6 m / 13...20 ft ❷	
Coaxial probe Ø21 mm / 0.8"	0.8...6 m / 2.5...20 ft ❸	

### Output

Output signal (Output 1)	4...20 mA HART® or 3.8...20.5 mA acc. to NAMUR NE 43	
Output signal (Output 2) ❹	4...20 mA (no HART® signal) or 3.8...20.5 mA acc. to NAMUR NE 43	
Resolution	±3 µA	
Temperature drift	Typically 50 ppm/K	
Error signal	High: 22 mA; Low: 3.6 mA acc. to NAMUR NE 43	

### Reference conditions acc. to EN 60770

Temperature	+20°C ±5°C / +70°F ±10°F
Pressure	1013 mbar abs. ±20 mbar / 14.69 psig ±0.29 psig
Relative air humidity	60% ±15%

### Accuracy

Repeatability	±1 mm / ±0.04"	±10 mm / ±0.4"
Accuracy (in direct mode)		
Liquids	±3 mm / ±0.12"	±10 mm / ±0.4"
Interface	±10 mm / ±0.4" (εr constant)	±10 mm / ±0.4"
Minimum layer (interface)	50 mm / 2"	

### Process conditions

Ambient temperature	-40...+80°C / -40...+175°F (EEx i: see supplementary operating instructions or approval certificates)	
Storage temperature	-40...+85°C / -40...+185°F	
Flange temperature	-40...+200°C / -40...+390°F (EEx i: see supplementary operating instructions or approval certificates)	
Thermal shock resistance	100°C/min	
Operating pressure	-1...40 bar / -14.5...580 psig; subject to process connection used and flange temperature	
Product density	-	0.5...3 kg/l / 31...187 lb/ft³
Product viscosity	-	≤5000 mPas / ≤3.360 lb/fts
Dielectric constant (εr)		
Level in direct mode	≥1.4	
Interface in direct mode	εr(interface) >> εr(level)²	
Vibration resistance	IEC 68-2-6 and EN 50178 (10...57 Hz: 0.075 mm / 57...150 Hz: 1g)	
Protection category	IP 66/67 equivalent to NEMA 6-6X	

	BM 26 F standard	BM 26 F with float system
--	------------------	---------------------------

**Material**

Transmitter		
Housing	Aluminium; Stainless steel (1.4404 / 316 L) ④	
Probe: single rod	Stainless steel (1.4404 / 316 L); other materials on request	
Probe: single cable	Stainless steel (1.4401 / 316); other materials on request	
Probe: coaxial probe	Stainless steel (1.4404 / 316 L); other materials on request	
Process fitting	Stainless steel (1.4404 / 316 L)	
Gaskets	FKM/FPM [-40...+200°C / -40...+390°F]; Kalrez® 6375 [-20...+200°C / -5...+390°F]	
Weather protection (Option)	Stainless steel (1.4301 / 304)	
Conduit for remote housing (Option)	Zinc-coated steel in a PVC sheath [-40...+105°C / -40...+220°F]	
Bypass chamber		
Chamber	Stainless steel (1.4404 / 316 L)	
Float (option)	-	Stainless steel (1.4404 / 316 L); Titanium
Indicator tube (option)	-	Pyrex glass
Scale (option)	-	Stainless steel (1.4404 / 316 L)
Gaskets	Klingerit [-196...+400°C / -320...+750°F] ⑤	

**Process connections**

Flange	DN15...50 (PN40); 1/2" ... 2" (150 lb / 300 lb)
--------	---

**Drain and vent connections**

Drain	G 3/8; options: G 1/2; NPT 3/8, 1/2, 3/4; DN15, 25 (PN40) 1/2" ... 1" (150 lb / 300 lb)
Vent	DN25 (PN40); 1" (150 lb / 300 lb) ④

**Electrical connections**

Instrument terminal 1 - Non-Ex / EEx i	14...30 VDC ⑥
Instrument terminal 1 - EEx d	20...36 VDC ⑥
Instrument terminal 2 - Non-Ex / EEx i / EEx d	10...30 VDC ⑦
Cable entry	M20x1.5; NPT 1/2; G 1/2
Cable tightening capacity	0.5...1.5 mm <sup>2</sup>

**User interface**

Display1	9 lines, 160 x 160 pixels in 8-step greyscale with 4-button keypad	
Operating languages	English and a 2nd language: German, French, Italian, Spanish, Portuguese, Japanese, Chinese (Mandarin) or Russian	
Display 2	-	Indicator column - yellow/black rotating flaps, magnetically-coupled to float - with scale
Optional scale markings	-	m+cm; ft+in; %; volume units on request



	BM 26 F standard	BM 26 F with float system
--	------------------	---------------------------

### Design codes

Conformity to pressure equipment directives	PED 97/23/EC
Pressure vessel construction code	CODAP® 2000
Options	NACE MRO175 / ISO 15156

### Approvals

ATEX	ATEX II 1, 1/2, 2 G EEx ia IIC T6...T3; ATEX II 1/2, 2 G EEx d[ia] IIC T6...T3
------	--

### Variants, options and accessories

Variants	C: two side connections;	
	F: top side connection and bottom inline connection	
Options	Integrated LCD display with sun cover;	
	2nd current output;	
	Remote housing connected to the probe via a flexible conduit with a standard length of 2180 mm / 7 ft, 4720 mm / 15.5 ft, 9800 mm / 32 ft or 4880 mm / 48.5 ft ③	
	-	IP68 local indication ④
	-	Limit switches
Accessories	Weather protection	

① supplied on request. Contact KROHNE for price information.

② longer on request

③ for clean liquids and interface applications

④ optional

⑤ subject to process conditions

⑥ min./max. value for an output of 22 mA at the terminal

⑦ optional. Min./max. value for an output of 22 mA at the terminal (additional power supply needed - output only)

⑧ ATEX approval pending

⑨ column of rotating flaps magnetically coupled to float sliding on rod or cable probe. Contact KROHNE for price information. Not for the U.S. market.

## Technical data: optional level switches

	Standard (Non-Ex) switches					
Type code	MS20 STD/LC/PC/NN/BT	MS15 STD/LC/PC/NO/BT	MS15 STD/LC/AL/NN/HT	MS15 STD/LC/AL/NO/HT	MS15 STD/HC/PC/NN/BT	MS15 STD/HC/AL/NN/HT
Version	Low price, standard	NAMUR	High-temperature	NAMUR, high-temperature	High-power cut-out	High-power cut-out, high temperature

### Input

Device	Level switch mounted on the side of the BM 26 bypass chamber					
Function	Reed switch that is magnetically actuated by float in BM 26 bypass chamber					
Parameter	Level detection					
Switching capacity	30 VA; 0.5 A; 230 VAC	①	20 VA; 1.5 A; 250 VAC	①	3...100VA; 1.5 A; 250 VAC	3...100VA; 1.5 A; 250 VAC

### Accuracy

Hysteresis	Not applicable
------------	----------------

### Process conditions

Ambient temperature	-20...+120°C / -4...+250°F ②					
Process temperature	-40...+250°C / -40...+480°F	-40...+250°C / -40...+480°F	-40...+300°C / -40...+570°F	-40...+300°C / -40...+570°F	-40...+250°C / -40...+480°F	-40...+300°C / -40...+570°F
Protection category	IP 65 equivalent to NEMA 4-4X					

### Material

Switch housing	Polycarbonate	Polycarbonate	Aluminium	Aluminium	Polycarbonate	Aluminium
Bracket	Stainless steel					
Clamp	Stainless steel					

### Electrical connections

Cable entry	PG 9	PG 13.5	M20 x 1.5 ③	M20 x 1.5 ③	PG 13.5	M20 x 1.5 ③
-------------	------	---------	-------------	-------------	---------	-------------

① according to NAMUR 19234. Connect to a NAMUR amplifier.

② specify temperature if an insulation jacket is used

③ Optional: M25 x 1.5 or NPT $\frac{1}{4}$ . Cable fitting not supplied.

## Technical data: optional level switches

	Exi-approved switches			
Type code	MS20 EXI/LC/PC/NN/BT	MS15 EXI/LC/PC/NO/BT	MS15 EXI/LC/AL/NN/HT	MS15 EXI/LC/AL/NO/HT
Version	low price, standard	NAMUR	high-temperature	NAMUR, high-temperature

### Input

Device	Level switch mounted on the side of the BM 26 bypass chamber			
Function	Reed switch that is magnetically actuated by float in BM 26 bypass chamber			
Parameter	Level detection			
Switching capacity	0.5 A ①	②	1.5 A ①	②

### Accuracy

Hysteresis	Not applicable
------------	----------------

### Process conditions

Ambient temperature	④			
Process temperature	③	③	③	③
Protection category	IP 65 equivalent to NEMA 4-4X			

### Material

Switch housing	Polycarbonate	Polycarbonate	Aluminium	Aluminium
Bracket	Stainless steel			
Clamp	Stainless steel			

### Electrical connections

Power supply characteristics	See supplementary operating instructions or approval certificates.			
Cable entry	PG 9	PG 13.5	M20 x 1.5 ④	M20 x 1.5 ④

### Approvals

ATEX	ATEX II 1 G EEx ia IIC T3...T6
------	--------------------------------

- ① Only connect to a certified intrinsically-safe power supply. Safety values: see supplementary operating instructions or approval certificates.
- ② according to NAMUR 19234. Connect a NAMUR amplifier.
- ③ Dependant on temperature class: see supplementary operating instructions or approval certificates.
- ④ Optional: M25 x 1.5 or NPT $\frac{1}{4}$ . Cable fitting not supplied.



## Technical data: optional level switches

	Exd-approved switches		
Type code	MS15 EXD/LC/AL/NN/HT	MS15 EXD/LC/AL/NO/HT	MS15 EXD/HC/AL/NN/HT
Version	high-temperature	NAMUR, high-temperature	high-power cut-out, high-temperature

### Input

Device	Level switch mounted on the side of the BM 26 bypass chamber		
Function	Reed switch that is magnetically actuated by float in BM 26 bypass chamber		
Parameter	Level detection		
Switching capacity	20 VA; 1.5 A; 250 VAC	①	1.5 A ②

### Accuracy

Hysteresis	Not applicable		
------------	----------------	--	--

### Process conditions

Ambient temperature	③		
Process temperature	③	③	③
Protection category	IP 65 equivalent to NEMA 4-4X		

### Material

Switch housing	Aluminium	Aluminium	Aluminium
Bracket	Stainless steel		
Clamp	Stainless steel		

### Electrical connections

Cable entry	M20 x 1.5 ④	M20 x 1.5 ④	M20 x 1.5 ④
-------------	-------------	-------------	-------------

### Approvals

ATEX	ATEX II 1/2 G EEx d ia IIC T3...T6		
------	------------------------------------	--	--

- ① according to NAMUR 19234. Connect a NAMUR amplifier.
- ② Only connect to a certified intrinsically-safe power supply. Safety values: see supplementary operating instructions or approval certificates.
- ③ Dependant on temperature class: see supplementary operating instructions or approval certificates.
- ④ Optional: M25 x 1.5 or NPT $\frac{1}{4}$ . Cable fitting not supplied.

## Dimensions and Weights

Variant C: two side process connections

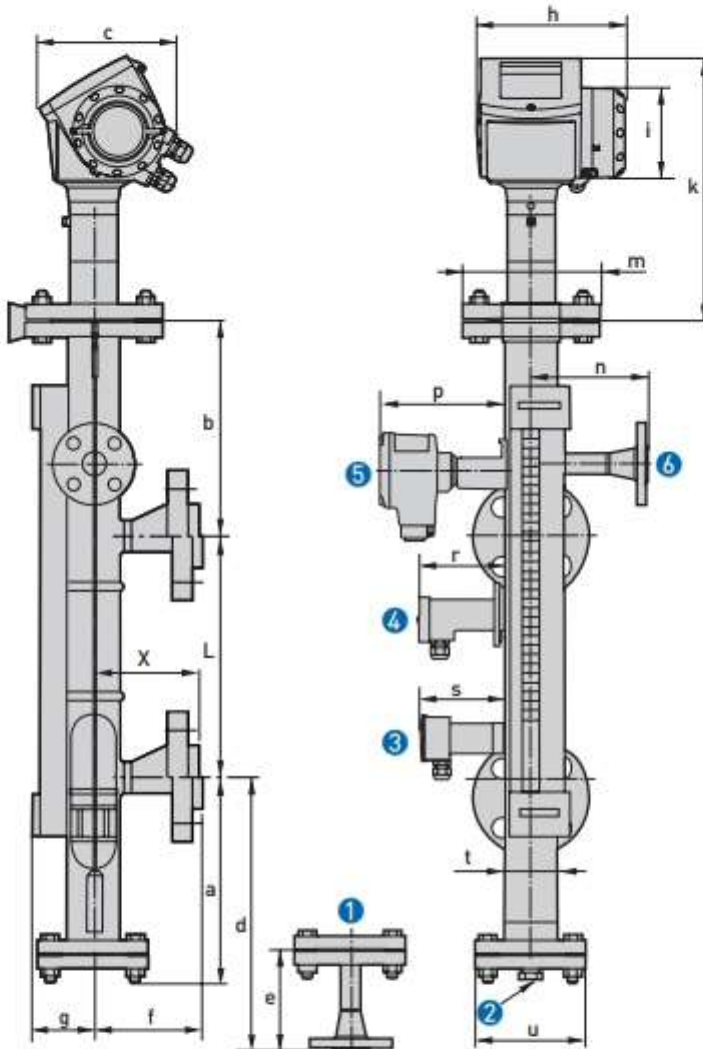

- ① Optional drain with welding neck flange connection
- ② Optional drain with G or NPT plug
- ③ Optional MS20 limit switch
- ④ Optional MS15 limit switch for low-temperature applications
- ⑤ Optional MS15 Exd limit switch for high-temperature and Ex d applications
- ⑥ Optional vent with welding neck flange connection

### Note:

- Cable glands are delivered on demand with non-Ex, EEx i- and EEx d-approved devices.
- Non-Ex and EEx i fittings are plastic and EEx d fittings are metallic. Non-Ex fittings are black and EEx i fittings are blue.
- The diameter of the outer sheath of the cable must be 6...12 mm or 0.2...0.5".
- Floats and local indication (column of rotating flaps) are optional. Limit switches are only available if the float option is chosen.

Dimensions in mm

	Dimensions [mm]																		
	a	b	c	d	e	f	X	g	h	i	k	L	m	n	p	r	s	t	u
Bypass chamber C ①	165	260	217	295 ②	116	115	③	72	180	∅ 109	305	500 ... 6000	∅16 5	140 ④	146 ⑤	100 ⑥	98 ⑦	∅72 x 2.3	∅ 130

- ① with two side process connections
- ② with optional drain (welding neck flange)
- ③ welding neck flanges: refer to "Process connection length, X" table at the end of this section
- ④ with optional vent
- ⑤ with optional MS15 limit switch for high-temperature and Ex d applications
- ⑥ with optional MS15 limit switch for low-temperature applications
- ⑦ with optional MS20 limit switch

Dimensions in inches

	Dimensions [inches]																		
	a	b	c	d	e	f	X	g	h	i	k	L	m	n	p	r	s	t	u
Bypass chamber C ①	6.5	10.2	8.5	11.6 ②	4.6	4.5	③	2.8	7.0	∅4. 3	12.0	20 ... 236	∅6. 5	5.5 ④	5.7 ⑤	4.0 ⑥	3.9 ⑦	∅2. 8 x 0.09	∅5. 1

- ① with two side process connections
- ② with optional drain (welding neck flange)
- ③ welding neck flanges: refer to "Process connection length, X" table at the end of this section
- ④ with optional vent
- ⑤ with optional MS15 limit switch for high-temperature applications
- ⑥ with optional MS15 limit switch for low-temperature applications
- ⑦ with optional MS20 limit switch

Weight in kg and lbs

Converter and chamber	Weight when L=1000 mm	Weight when L=40 inches	Weight for every additional 100 mm	Weight for every additional 4 inches
Chamber type	[kg]	[lbs]	[kg]	[lbs]
Bypass chamber	23.9	52.7	0.5	1.1
MS15 BT limit switch ①	0.13	0.3	-	-
MS15 HT limit switch ②	1.2	2.6	-	-
MS20 limit switch	0.086	0.2	-	-

- ① for low-temperature applications
- ② for high-temperature applications

Variant F: top side and bottom inline process connections

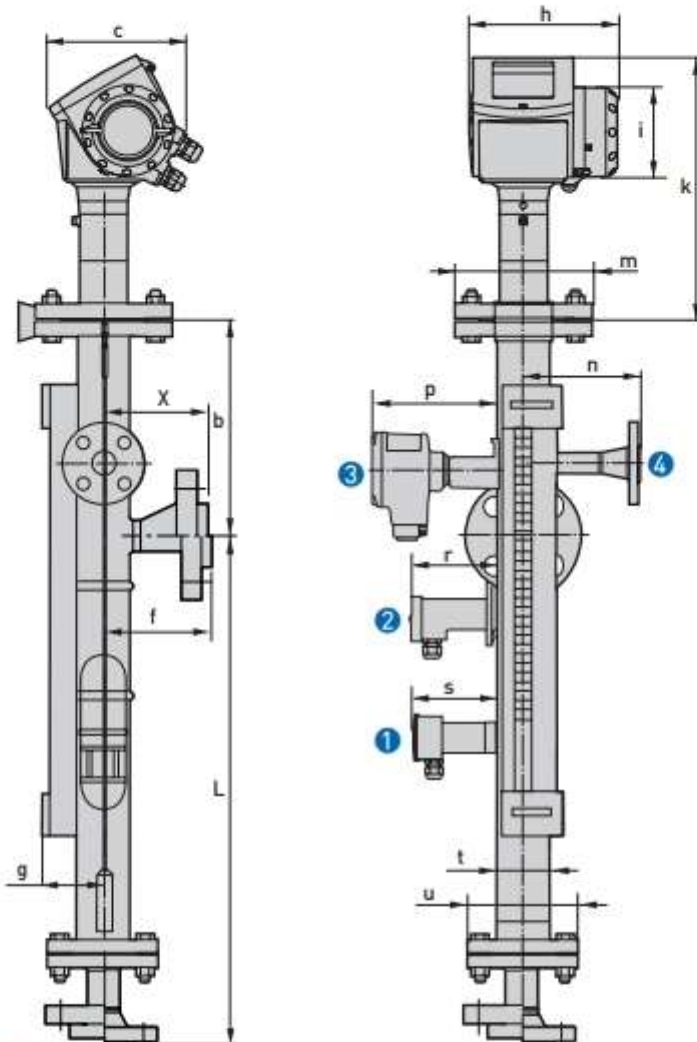

- ❶ Optional MS20 limit switch
- ❷ Optional MS15 limit switch for low-temperature applications
- ❸ Optional MS15 limit switch for high-temperature or Ex d applications
- ❹ Optional vent with welding neck flange connection

Note:

- Cable glands are delivered on demand with non-Ex, EEx i- and EEx d-approved devices.
- Non-Ex and EEx i fittings are plastic and EEx d fittings are metallic. Non-Ex fittings are black and EEx i fittings are blue.
- The diameter of the outer sheath of the cable must be 6...12 mm or 0.2...0.5".
- Floats and local indication are optional. Limit switches are only available if float option is chosen.

Dimensions in mm

	Dimensions [mm]															
	b	c	f	X	g	h	i	k	L	m	n	p	r	s	t	u
Bypass chamber F ①	260	165	115	②	72	180	∅ 109	305	500 ... 6000	∅165	140 ③	146 ④	100 ⑤	98 ⑥	∅72 x 2.3	∅ 130

- ① with top side and bottom in-line process connections
- ② welding neck flanges: refer to "Process connection length, X" table at the end of this section
- ③ with optional vent (welding neck flange)
- ④ with optional MS15 limit switch for high-temperature and Ex d applications
- ⑤ with optional MS15 limit switch for low-temperature applications
- ⑥ with optional MS20 limit switch

Dimensions in inches

	Dimensions [inches]															
	b	c	f	X	g	h	i	k	L	m	n	p	r	s	t	u
Bypass chamber F ①	10.2	6.5	4.5	②	2.8	7.0	∅4.3	12.0	20 ... 236	∅6.5	5.5 ③	5.7 ④	4.0 ⑤	3.9 ⑥	∅2.8 x 0.09	∅5.1

- ① with top side and bottom in-line process connections
- ② welding neck flanges: refer to "Process connection length, X" table at the end of this section
- ③ with optional vent (welding neck flange)
- ④ with optional MS15 limit switch for high-temperature and Ex d applications
- ⑤ with optional MS15 limit switch for low-temperature applications
- ⑥ with optional MS20 limit switch

Weight in kg and lbs

Converter and chamber	Weight when L=1000 mm	Weight when L=40 inches	Weight for every additional 100 mm	Weight for every additional 4 inches
Chamber type	[kg]	[lbs]	[kg]	[lbs]
Bypass chamber	23.9	52.7	0.5	1.1
MS15 BT limit switch ①	0.13	0.3	-	-
MS15 HT limit switch ②	1.2	2.6	-	-
MS20 limit switch	0.086	0.2	-	-

- ① for low-temperature applications
- ② for high-temperature applications



Remote housing

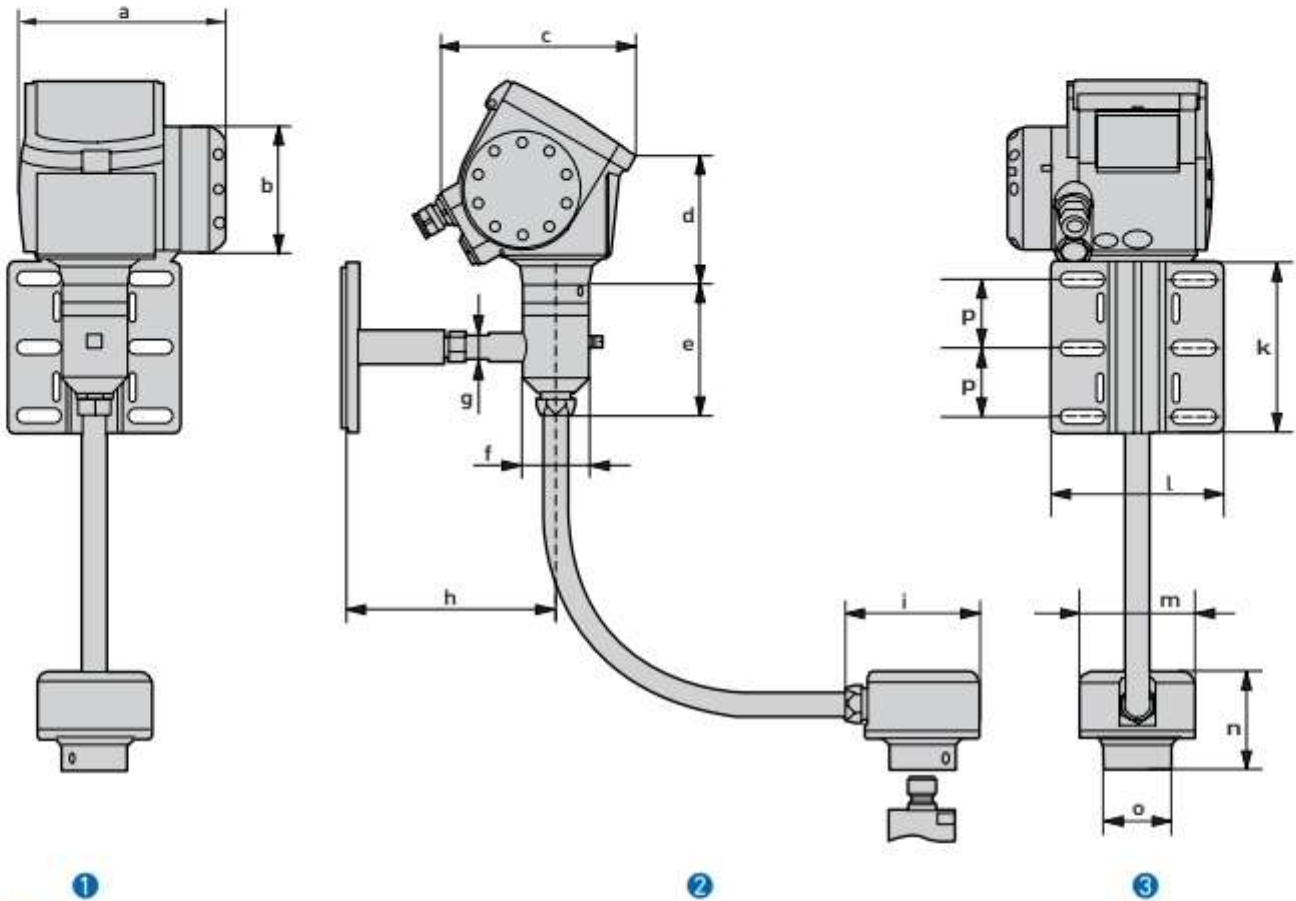

- 1 Front view
- 2 Left side
- 3 Rear view

Dimensions and Weights in mm and kg

	Dimensions [mm]															Weight [kg]
	a	b	c	d	e	f	g	h	i	k	l	m	n	o	p	
Remote version	180	109	165	193	98.5	58	21	183	117	150	150.4	100	86	58	60	6.6...12.85

1 wall bracket (1.4 kg) + housing support (1.5 kg) + remote probe housing (2.7 kg) + flexible conduit (2 m: 1 kg; 4.5 m: 2.25 kg; 9.5 m: 4.75 kg; 14.5 m: 7.25 kg)

Dimensions and Weights in inches and lbs

	Dimensions [inches]															Weight [lbs]
	a	b	c	d	e	f	g	h	i	k	l	m	n	o	p	
Remote version	7.09	4.29	6.50	7.60	3.88	2.28	0.83	7.20	4.60	5.91	5.92	3.94	3.39	2.28	2.36	14.6...28.3

1 wall bracket (3.1 lbs) + housing support (3.3 lbs) + remote probe housing (6.0 lbs) + flexible conduit (6.6 ft: 2.2 lbs; 14.8 ft: 5.0 lbs; 31.2 ft: 10.5 lbs; 47.6 ft: 16.0 lbs)

### Remote version limits

- For interface applications the maximum the max. extension length is 4.5 m / 14.8 ft.
- For liquid level applications, the maximum measuring range is reduced according to the length of the electric cable between the flange and the converter (extension length).

Max. measuring range		Extension length options	
[m]	[ft]	[m]	[ft]
5	16.4	14.5	47.6
6	19.7	9.5	31.2
		4.5	14.8
		2	6.6

### Applications

- Tank with a lot of vibration
- Limited space on the top of the tank or limited access (due to the size of the compact converter)
- Remote display on the bottom of the tank

Tables for process connection length, X

Process connection length, X, in mm [EN welding neck flanges]

Nominal size	Pressure rating	Process connection length, X
DN	PN	[mm]
15	40	79.5
20	40	81.5
25	40	81.5
40	40	86.5
50	40	89.5

Process connection length, X, in inches [EN welding neck flanges]

Nominal size	Pressure rating	Process connection length, X
DN	PN	[inches]
15	40	3.13
20	40	3.21
25	40	3.21
40	40	3.41
50	40	3.52

Process connection length, X, in mm (ASME welding neck flanges flanges)

Nominal size	Pressure rating	Process connection length, X
ASME		[mm]
½"	150LB	89.5
¾"	150LB	93.5
1"	150LB	97.5
1 ¼"	150LB	103.5
2"	150LB	104.5
½"	300LB	93.5
¾"	300LB	98.5
1"	300LB	103.5
1 ¼"	300LB	109.5
2"	300LB	111.5

Process connection length, X, in inches (ASME welding neck flanges)

Nominal size	Pressure rating	Process connection length, X
ASME		[inches]
½"	150LB	3.52
¾"	150LB	3.84
1"	150LB	4.07
1 ¼"	150LB	4.11
2"	150LB	3.68
½"	300LB	3.68
¾"	300LB	3.88
1"	300LB	4.07
1 ¼"	300LB	4.31
2"	300LB	4.39

## Guidelines for maximum operating pressure

**Note:**

Ensure that meters are used within their operating limits. Observe the following requirements.

Flanged connections for BM 26 chamber according to EN 1092-1:

Pressure / temperature de-rating for 316 L (1.4404) stainless steel meters

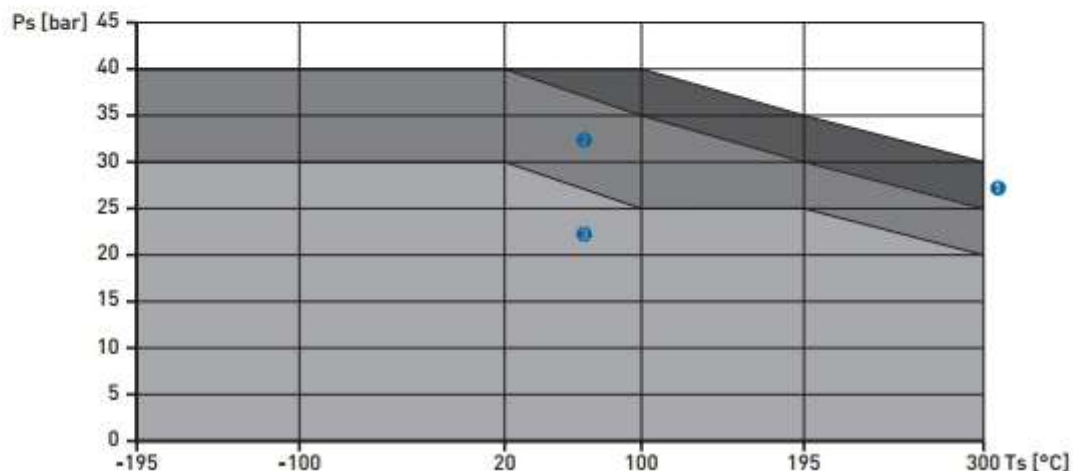

- ① Loose and Welding Neck PN40 flanges for sizes DN15 and DN20
- ② Loose and Welding Neck PN40 flange for size DN25
- ③ Loose and Welding Neck PN40 flanges for sizes DN40 and DN50

Flanged connections for BM 26 chamber according to ASME:

Pressure / temperature de-rating for 316 L (1.4404) stainless steel meters

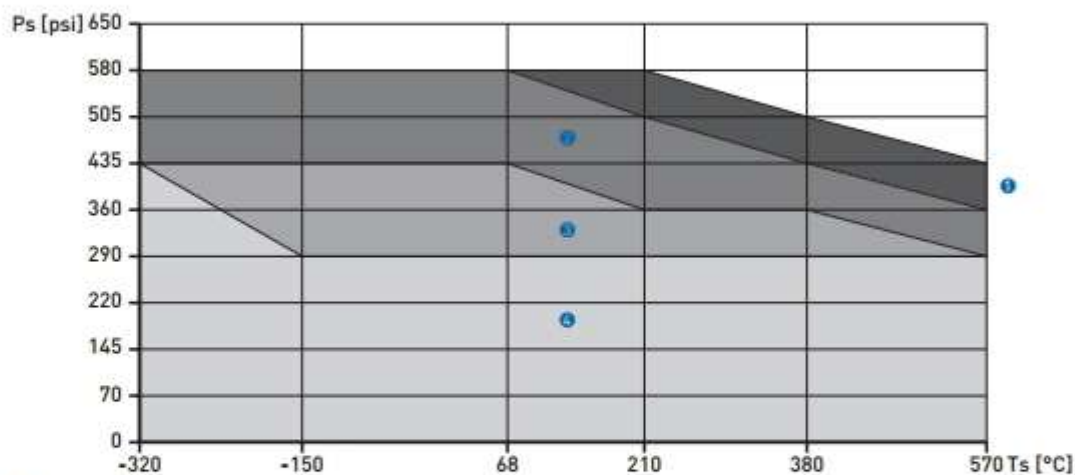

- ① ASME 300 lb flanges for sizes ½" and ¾"
- ② ASME 300 lb flange for size 1"
- ③ ASME 300 lb flanges for sizes 1½" and 2"
- ④ ASME 150 lb flanges for sizes ½", ¾", 1, 1½", and 2"



## Notes

## KROHNE Product Overview

- Electromagnetic flowmeters
- Variable area flowmeters
- Mass flowmeters
- Ultrasonic flowmeters
- Vortex flowmeters
- Flow controllers
- Level measuring instruments
- Pressure gauges
- Temperature measuring instruments
- Water solutions & analysis
- Oil and gas turnkey solutions

### Addresses:

#### Germany

##### Northern sales office

KROHNE Messtechnik GmbH & Co. KG  
Bremer Str. 133  
D-21073 Hamburg  
Phone: +49 (0)40 767 3360  
Fax: +49 (0)40 767 33612  
nor@krohne.de  
ZIP code: 10000 - 29999, 49000 - 49999

##### Western and middle sales office

KROHNE Messtechnik GmbH & Co. KG  
Ludwig-Krohne-Straße  
D-47058 Duisburg  
Phone: +49 (0)203 301 416  
Fax: +49 (0)203 301 10416  
west@krohne.de  
ZIP code: 30000 - 34999, 37000 - 48000, 50000 - 53999, 57000 - 59999, 98000 - 99999

##### Southern sales office

KROHNE Messtechnik GmbH & Co. KG  
Landsberger Str. 392  
D-81241 Munich  
Phone: +49 (0)89 121 5620  
Fax: +49 (0)89 129 6190  
sued@krohne.de  
ZIP code: 0 - 9999, 80000 - 89999, 90000 - 99999

##### Southwestern sales office

KROHNE Messtechnik GmbH & Co. KG  
Rüdesheimer Str. 40  
D-65239 Hochheim/Main  
Phone: +49(0)6146 827 30  
Fax: +49 (0)6146 827 312  
rhein-main@krohne.de  
ZIP code: 35000 - 36999, 54000 - 56999, 60000 - 79999

##### Instrumentation and control equipment catalog

TABLAR Messtechnik GmbH  
Ludwig-Krohne-Straße 5  
D-47058 Duisburg  
Phone: +49 (0)203 305 880  
Fax: +49 (0)203 305 888  
kontakt@tablar.de www.tablar.de

#### KROHNE sales companies

##### International

**Australia**  
KROHNE Australia Pty Ltd  
Quantum Business Park 10/287  
Victoria Rd Rydalmere NSW 2116  
Phone: +61 2 8846 1700  
Fax: +61 2 8846 1755  
krohne@krohne.com.au

**Austria**  
KROHNE Austria Ges.m.b.H.  
Medecenterstraße 14  
A-1030 Vienna  
Phone: +43 (0)1/203 45 32  
Fax: +43 (0)1/203 47 78  
info@krohne.at

**Belgium**  
KROHNE Belgium N.V.  
Brusselstraat 320  
B-1702 Groot Bijgaarden  
Phone: +32 (0)2 4 66 00 10  
Fax: +32 (0)2 4 66 08 00  
krohne@krohne.be

**Brazil**  
KROHNE Conaut Controles  
Automaticos Ltda.  
Estrada Das Águas Espraiadas, 230  
C.P. 56 06835 - 080 EMBU - SP  
Phone: +55 (0)11-4785-2700  
Fax: +55 (0)11-4785-2768  
conaut@conaut.com.br

**China**  
KROHNE Measurement Instruments  
(Shanghai) Co. Ltd., (KMIC)  
Room 1501  
1033 Zhaojiabang Road  
Shanghai 200030  
Phone: +86 21 4687 9611  
Fax: +86 21 6438 7110  
info@krohne-asia.com

**Czech Republic**  
Selsaická 156  
63800 Brno  
Phone: +420 (0)545 242 577  
Fax: +420 (0)545 220 093  
brno@krohne.cz

**France**  
KROHNE S.A.S.  
Les Ors BP 98  
F-26103 ROMANS Cedex  
Phone: +33 (0)4 75 05 44 00  
Fax: +33 (0)4 75 05 00 48  
info@krohne.fr

**Great Britain**  
KROHNE Ltd.  
Rutherford Drive  
Park Farm Industrial Estate  
Wellingborough  
Northants NN8 6AE  
Phone: +44 (0)19 33 408 500  
Fax: +44 (0)19 33 408 501  
info@krohne.co.uk

**CIS**  
Janex KROHNE Engineering AG  
Business-Centre Planeta  
Office 404 ul.  
Marxistakaja 3  
109147 Moscow/Russia  
Phone: +7 (0)095 911 7145  
Fax: +7 (0)095 742 8873  
krohne@do.ru

**India**  
Krohne Marshall Ltd.  
A-34/35, M.L.D.C. Industrial Area,  
H-Block  
Pimpri Poona 411018  
Phone: +91 (0)202 744 2020  
Fax: +91 (0)202 744 2020  
pcu@krnl.net

**Iran**  
KROHNE Liaison Office  
North Sahravard Ave. 26,  
Sarmad St. Apt. #9  
Tehran 15537  
Phone: +9821 8874 5973  
Fax: +9821 8850 1268  
krohne@krohneiran.com

**Italy**  
KROHNE Italia Srl.  
Via V. Monti 75  
I-20145 Milan  
Phone: +39 02 4300 661  
Fax: +39 02 4300 6666  
info@krohne.it

**Korea**  
KROHNE Korea  
Room 508 Miron Bldg 43  
Yoido-Dong Youngdeungpo-Ku  
Seoul, Korea  
Phone: 00-82-2-782-1900  
Fax: 00-82-2-780-1749  
krohnekorea@krohnekorea.com

**Netherlands**  
KROHNE Nederland B.V.  
Kerkpleat 14  
NL-3313 LC Dordrecht  
Phone: +31 (0)78 630 6200  
Fax: +31 (0)78 630 6405  
Service Direct: +31 (0)78 630 6222  
info@krohne.nl

**Norway**  
KROHNE Norway A.S.  
Eikholtsveien 114  
NO-1521 Moss  
Phone: +47 (0)69 264 860  
Fax: +47 (0)69 267 333  
postmaster@krohne.no

**Poland**  
KROHNE Polska Sp.z o.o.  
ul. Stary Rynek Olivski 8a  
80-324 Gdansk  
Phone: +48 (0)58 520 9211  
Fax: +48 (0)58 520 9212  
info@krohne.pl

**Switzerland**  
KROHNE AG  
Uferstr. 90  
CH-4019 Basel  
Phone: +41 (0)61 638 30 30  
Fax: +41 (0)61 638 30 40  
info@krohne.ch

**Singapore**  
Tokyo Keiso - KROHNE (Singapore)  
Pte. Ltd.  
14, International Business Park,  
Jurong East  
Chiyoda Building, #01-01/02  
Singapore 609922  
Phone: (65) 6567 4548  
Fax: (65) 6567 9874  
tk@tokyokeiso-krohne.com.sg

**Republic of South Africa**  
KROHNE Pty. Ltd.  
Bushbuck Close  
Corporate Park South  
Midrand, Gauteng  
P.O. Box 2069  
Midrand, 1685  
Phone: +27 (0)11 314 1391  
Fax: +27 (0)11 314 1661  
midrand@krohne.co.za

**Spain**  
LL KROHNE IBERIA, S.r.l.  
Poligono Industrial Nike  
Calle Brasil, nº. 5  
28806 Alcalá de Henares Madrid  
Phone: +34 (0)91 883 2152  
Fax: +34 (0)91 883 4854  
krohne@krohne.es

**USA**  
KROHNE, Inc.  
7 Dearborn Road  
Peabody, MA 01960  
Phone: +1 (800) FLOWING  
Phone: +1 (978) 535 6040 (in MA)  
info@krohne.com

#### Representatives

Algeria  
Argentina  
Cameroon  
Canada  
Chile  
Colombia  
Croatia  
Denmark  
Ecuador  
Egypt  
Finland  
Gabon  
Ghana  
Greece  
Hong Kong  
Hungary  
Indonesia  
Iran  
Ireland  
Israel  
Ivory Coast  
Japan  
Jordan  
Kuwait  
Libya  
Lithuania  
Malaysia  
Mauritius  
Mexico  
Morocco  
New Zealand  
Peru  
Portugal  
Romania  
Saudi Arabia  
Senegal  
Slovakia  
Slovenia  
Sweden  
Taiwan  
Thailand  
Tunisia  
Turkey  
Venezuela  
Yugoslavia

#### Other countries

KROHNE Messtechnik GmbH & Co. KG  
Ludwig-Krohne-Str. 5  
D-47058 Duisburg  
Phone: +49 (0)203 301 0  
Fax: +49 (0)203 301 389  
expert@krohne.de

