

# AUTROL®



## Smart Pressure Transmitter

for Differential / High Static / Gauge / Absolute Pressure Measurement



MODEL

# APT3500

- ... Best performance 0.04%
- ... High Accuracy
- ... Five-year stability under Actual process conditions

Duon System Co.,Ltd.  
[www.autrol.com](http://www.autrol.com)



# APT3500



Standard



SST Housing



High Static Pressure

## Description of Product

The APT3500 Smart Pressure Transmitter is a micro processor-based high performance transmitter, which has flexible pressure calibration and output, automatic compensation of ambient temperature and process variable, configuration of various parameters, communication with HART protocol. The application is very various, as measuring liquid, gas or steam flow as well as pressure and liquid level by application method. All data of sensor is to be input, modified and stored in EEPROM.

## Function

- » Flexible Sensor Input : DP, HS, GP, AP
- » Various Output : 4~20mA, Digital Signals
- » Setting Various Parameters : Zero/Span, Trim, Unit, Fail-mode, etc.
- » Self Diagnostic Function : Sensor, Memory A/D Converter, Power, etc.
- » Digital Communication with HART protocol
- » Explosion-proof Approval & Intrinsic Safety Approval : ATEX, FM, FMCanada, KC's, etc.
- » Marine Certificate: ABS, LR, BR, DNV

## Features

- » **Superior Performance**
  - High Reference Accuracy:  $\pm 0.04\%$  of Calibrated Span
  - for range 1 (DP & GP)
    - $\pm 0.10\%$  of Span
    - For spans less than 4:1, accuracy =  $\pm [0.025 \times (\text{URL}/\text{span})] \%$  of span
  - for range 2 (DP & GP)
    - $\pm 0.10\%$  of Span
    - For spans less than 10:1, accuracy =  $\pm [0.05 + 0.005 \times (\text{URL}/\text{span})] \%$
  - for ranges 3 ~ 5 (DP & GP & HS)
    - $\pm 0.040\%$  of Span
    - For spans less than 5:1, accuracy =  $\pm [0.015 + 0.005 \times (\text{URL}/\text{span})] \%$
  - for DP6 & GP6 & HS7 & AP 3~5
    - $\pm 0.075\%$  of Span
    - For spans less than 10:1, accuracy =  $\pm [0.025 + 0.005 \times (\text{URL}/\text{span})] \%$
  - Long-Term Stability (0.125% URL for 5year)
  - High Rangeability (100:1) (for the range 3~6)
- » **Flexibility**
  - Data Configuration with HART Configurator
  - Zero Point Adjustment
- » **Reliability**
  - Continuous Self-Diagnostic Function
  - Automatic Ambient Temperature Compensation
  - Fail-mode Process Function
  - EEPROM Write Protection
  - CE EMC Conformity Standards (IEC 61000-4 Series)

- Transfer Function
- Self-Compensation
- » **Self-Diagnosis and Others**
  - CPU & Analog Module Fault Detection
  - Communication Error
  - Fail-mode Handling
  - LCD Indication
  - Temperature Measurement of Sensor Module

## Function

- » **Range and Sensor Limits**
  - Refer to Table 1.
- » **Zero and Span Adjustment Limits**
  - Zero and span values can be set anywhere within the range limits stated in Table 1.(Page 9)
  - Span must be greater than or equal to the minimum span stated in Table 1.(Page 9)
- » **Output (Analog Current and Digital Data)**
  - LCD Display & ENG Mode
  - Two wire 4~20mA user-configurable for linear or square root output, digital process value superimposed on 4~20mA signal, available to any host that conforms to the HART protocol
- » **Power Supply & Load Requirement**
  - External power supply required.
    - \* 250 ohm load - 17.5 Vdc
    - \* up to a 550 ohm load - 24 Vdc
  - Max. Loop Resistance =  $(E - 12) / 0.022$  (E = Power Supply Voltage)
  - Voltage Range : 12 to 45 Vdc
  - Voltage Rating : 24 Vdc  $\pm 30\%$
  - Loop Load
    - 0 ~ 1500 ohm - Operation
    - 250 ~ 550 ohm - HART Communications

## Transmitter Description

APT3500 Pressure transmitter can be easily configured from any host that support the HART protocol.

- » **Basic Setup**
  - Operational Parameters.
  - 4~20mA Points (Zero/Span)
  - Engineering Units
  - Damping Time : 0.25 ~ 60 sec
  - Tag : 8 alphanumeric characters
  - Descriptor : 16 characters
  - Message : 32 characters.
  - Date : day/month/year
- » **Calibration and Trimming**
  - Lower/Upper Range (zero/span)
  - Sensor Zero Trimming
  - Zero Point Adjustment
  - DAC Output Trimming

- » **EMC Conformity Standards**
  - IEC 61000-4 Series
- » **Failure Mode**
  - Fail High : Current  $\geq 21.1$  mA
  - Fail Low : Current  $\leq 3.78$  mA
- » **Storage Temperature**
  - $-40^{\circ}\text{C}$  to  $85^{\circ}\text{C}$  (without condensing)
- » **Process Temperature Limits**
  - (Range codes and approval codes may effect limits)
  - $-40^{\circ}\text{C}$  to  $120^{\circ}\text{C}$  ( $-104$  to  $248^{\circ}\text{F}$ )

## Functional Block Diagram

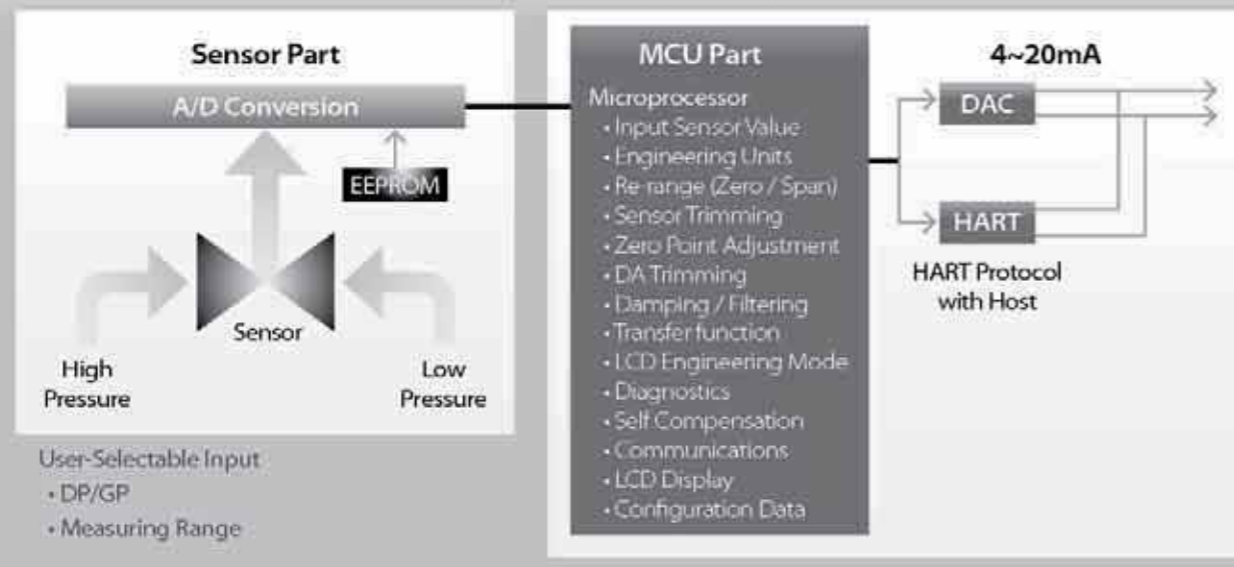

\* Subject to change without notice



## Function

- » **Isolation**
  - Input/output isolated to 500Vrms (707Vdc)
- » **Working Pressure Limits (silicone oil)**
  - Model D & G
    - 0 ~ 5 MPa - # 1
    - 0 ~ 13 MPa - # 2
    - 0 ~ 25 MPa - # 3~6
  - Model HS
    - 0 ~ 32 MPa - # 3~5
    - 0 ~ 75 MPa - # 7
  - Model AP
    - 0 ~ 0.25 MPa - # 3
    - 0 ~ 1.5 MPa - # 4
    - 0 ~ 2.5 MPa - # 5

- » **Hydrostatic Test Pressure**
  - Model D & G
    - 8 MPa - # 1
    - 20 MPa - # 2
    - 38 MPa - # 3~6
  - Model HS
    - 48 MPa - # 3~5
    - 60 MPa - # 7
  - Model AP
    - 0 ~ 0.38 MPa - # 3
    - 0 ~ 2.25 MPa - # 4
    - 0 ~ 3.75 MPa - # 5

- » **Burst Pressure**
  - Model D & G
    - 69 MPa - # 1~6
  - Model HS
    - 132 MPa - # 3~5
    - 80 MPa - # 7
  - Model AP
    - 1.05 MPa - # 3
    - 4 MPa - # 4
    - 7 MPa - # 5

- » **5 Digit LCD**
  - Express all pressure unit and flow unit.
  - Use 5 digit.
  - Select decimal place (0 to 4)
  - PV, % and mA value indicate on LCD rotationally & automatically.

### » User define unit function



### » Change main parameter by Button

- Change Unit
- Change Upper range value
- Change Lower range value
- Change the Damping Second
- Select the Decimal Place
- Zero Trim
- Zero Adjustment



Moving within Menu : Zero  
 Moving to below Menu : Span  
 Moving Top Menu : Zero+Span

## Button Menu tree

### » Button Menu tree

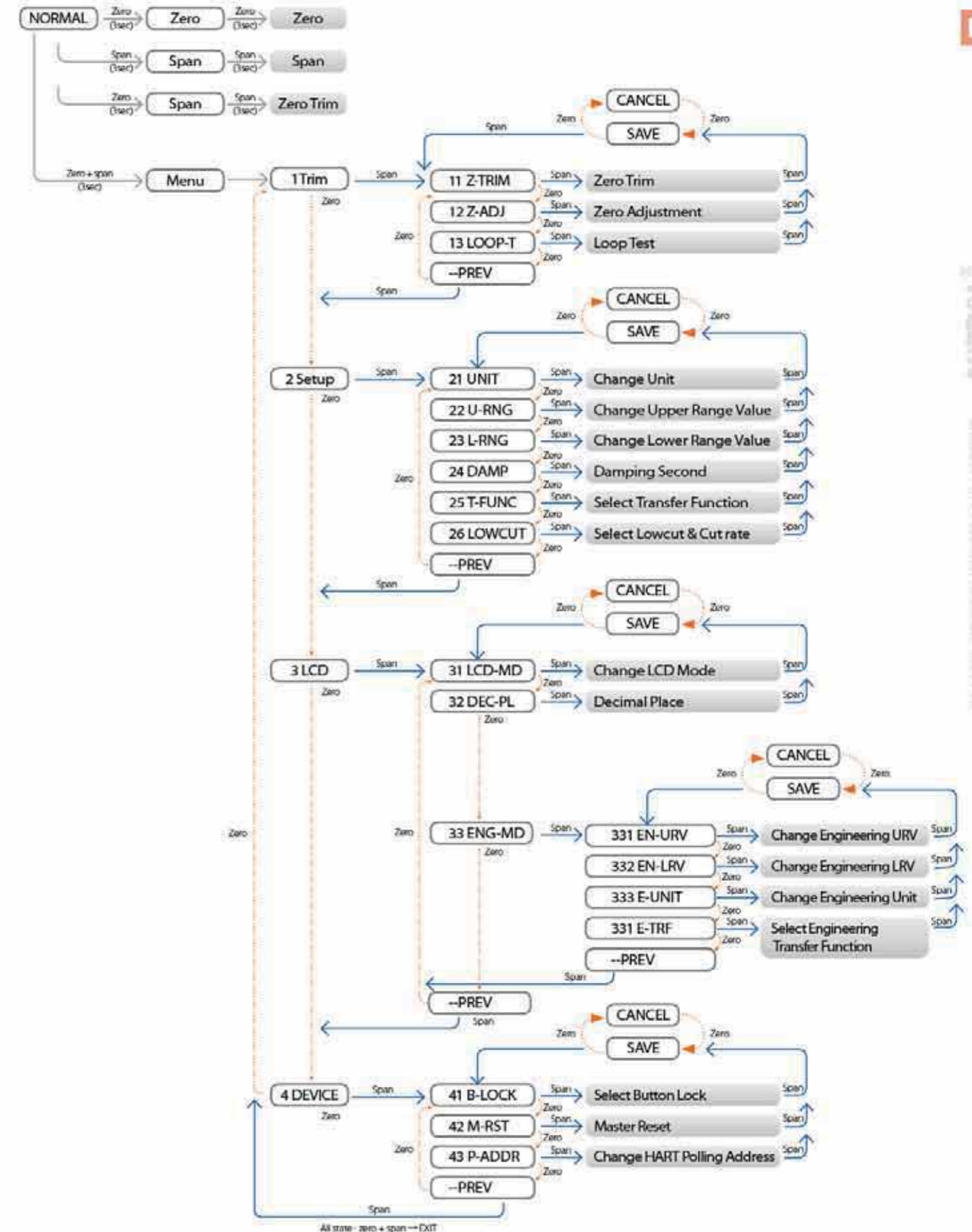

All state zero + span → EXIT





## Physical Specifications

### » Wetted Materials

- Isolating Diaphragms: 316L SST, Monel, Tantalum, HAST-C
- Drain/Vent Valves: 316 SST, HAST-C
- Flanges and Adapters: 316 SST (ASTMCF8M), HAST-C
- O-ring: Viton, PTFE

### » Non-wetted materials

- Fill Fluid: Silicone oil or Inert fill
- Bolts: 304 SST
- Electronics Housing: Aluminum or 316L SST (Option) Flameproof and Waterproof (IP67)
- Cover O-ring: Buna-N
- Paint: Epoxy Polyester or Polyureth
- Mounting Bracket: 304SST with U-bolt (304SST) for 2-inch pipe
- Nameplate: 304 SST

### » Electrical connections

- 1/2-14 NPT conduit with M4 Screw Terminals

### » Process Connections

- 1/4-18 NPT on 2.126 inch (54.0 mm) centers on flanges for Standard
- 1/2-14 NPT on Process Adapter (option)
- \* Refer to drawing in the last page

### » Weight

- 3.51 kg ( Standard - excluding options )
- 5kg (SST Housing- excluding options)

## Hazardous Location Certifications (option)

### » Explosive-proof Certification :

- KCs (Korea Certification)
- Type : Flameproof (Ex d IIC T6, IP67 (-200°C ≤ Tamb ≤ +600°C))
- Certificate No. : 12-AV2BO-0741
- Power Supply : 12.5 ~ 45Vdc, 4 ~ 20mA, Process Temperature : +800°C

### » ATEX Approvals E1 Code :

- Type : ATEX Explosion-proof Certification
- Certification No. : DNV 14 ATEX 5433X
- Ex II 2 G Ex d IIC T6..T4, IP66/67
- Vcd = 12.5 ~ 45Vdc, 4~20mA.

### » KCs Intrinsic Safety Certification K2 Code :

### » FM and FMc Certification F1 & F2 Code :

### » ATEX Intrinsic Safety Approvals E2 Code :

\* Some certificates are on pending for approval. Please ask us before order.

## Exploded drawing of APT3500

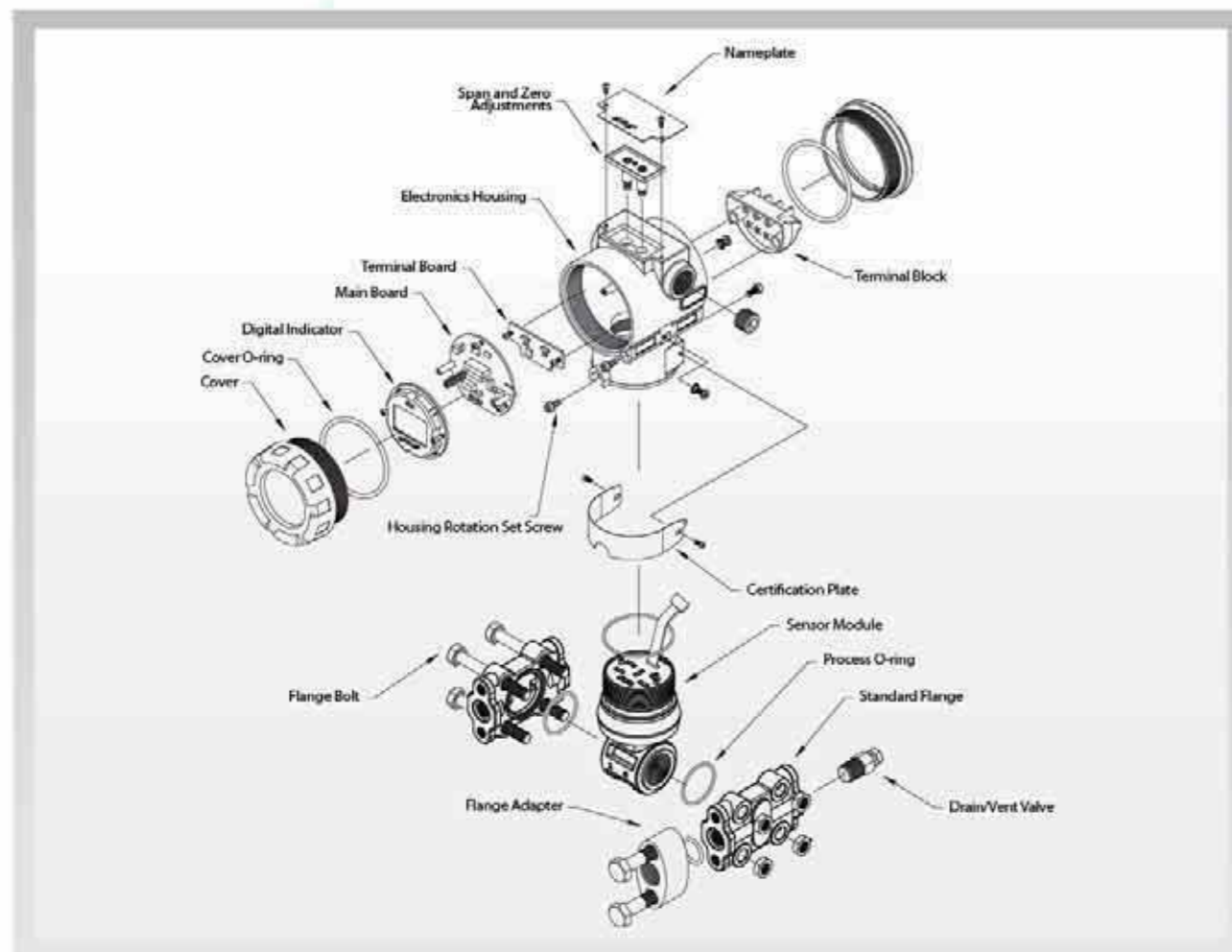

## Connection Diagram of Signal, Power, HHT for Transmitter

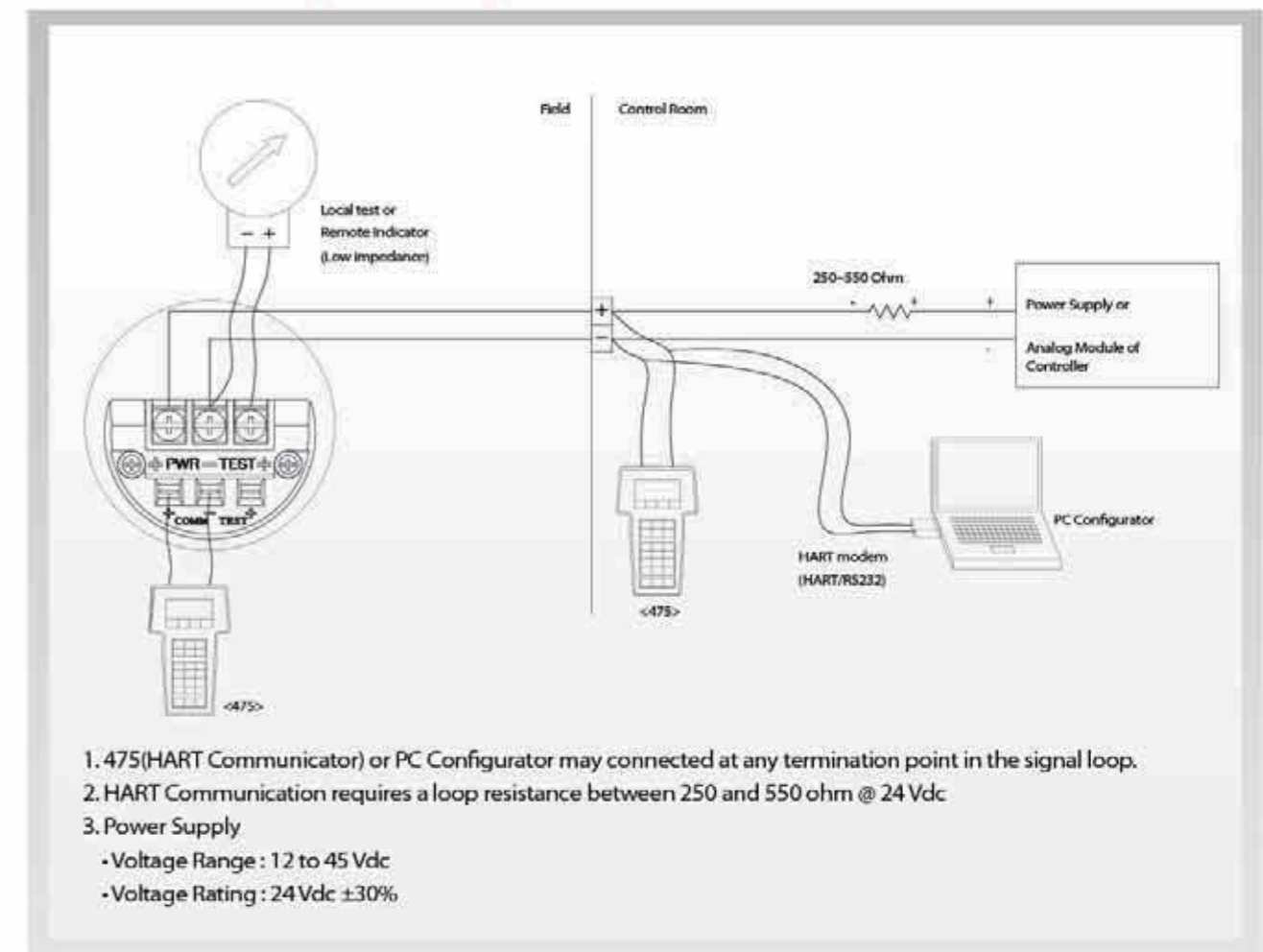



# APT3500

## Bottom Connection for Vertical Process Line

*Easy Installation,  
Vertical Process line.  
Industrial standard connection.  
Not require additional  
retrofitted Flanges or Adapters.*

### Background

Traditionally, some of applications require vertical installation such as flow application, orifice assemble line, special location and etc. The traditional connections may require additional flanges or adapters, which is inconvenience and additional charge. (Except changing size of process connection).

### Advantage

Direct connection from vertical process line with manifold. And it is not required additional retrofitted flanged or adapter to connect vertical process line or assemble manifold because it has industrial standard size 54 mm between L & H process connection in the transmitter. Moreover, Manifold can be connected directly.

### Dimension

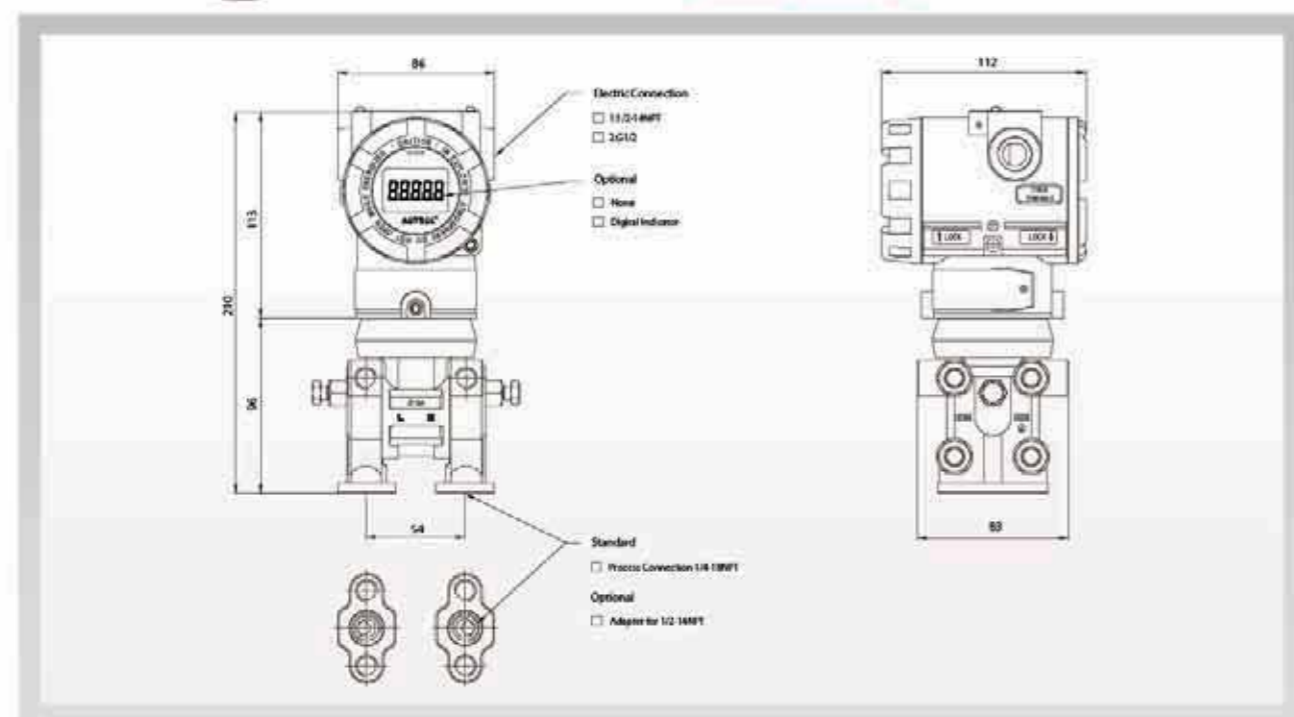

## General Specifications

(Rangeability: #1=20:1 / #2=50:1 / 4=6=100:1)

### 1. APT3500 Pressure Sensor Range

<Table 1>

Range Code	DP		GP		AP		HS	
	Calibrated Span(KPa)	Lower Range(KPa)	Calibrated Span(KPa)	Lower Range(KPa)	Calibrated Span(KPa)	Lower Range(KPa)	Calibrated Span(KPa)	Lower Range(KPa)
1	0.0625 ~ 1.25	-1.25	0.0625 ~ 1.25	-1.25				
2	0.15 ~ 7.5	-7.5	0.15 ~ 7.5	-7.5				
3	0.65 ~ 65	-65	0.65 ~ 65	-65	2.5 ~ 250	0	0.65 ~ 65	-65
4	2.5 ~ 250	-250	2.5 ~ 250	-100	15 ~ 1500	0	2.5 ~ 250	-250
5	21 ~ 2100	-2100	21 ~ 2100	-100	25 ~ 2500	0	21 ~ 2100	-2100
6	140 ~ 14000	-14000	140 ~ 14000	-100				
7							400 ~ 40000 (Gauge Only)	0

Code	KPa	Kgf/cm <sup>2</sup>	bar	psi	inH <sub>2</sub> O@4°C	mmH <sub>2</sub> O@4°C	inHg@0°C
1	1.25	0.012	0.0125	0.181	5.018	127.464	0.369
2	7.5	0.076	0.075	1.087	30.11	764.787	2.214
3	65	0.662	0.65	9.427	260.958	6628.154	19.194
4	250	2.549	2.5	36.259	1003.685	25492.9	73.825
5	2100	21.414	21	304.579	8430.958	214140.359	620.129
6	14000	142.76	140	2030.527	56206.38	1427602	4134.197

### 2. Electrical Specifications

Power Supply	12 to 45 Vdc	Output Signal	4 ~ 20 mA dc / HART
HART loop resistance	250 ~ 550 ohm	Isolation	500 Vrms (707 Vdc)

### 3. Performance Specifications

Reference Accuracy	±0.04% of Span *See the specification feature on 3page	Ambient Temperature	-40 ~ +85°C		
		LCD Meter Ambient Temp	-30 ~ +80°C		
Ambient Temp. Effect	Range 1(DP&GP) ±[0.2% URL+0.08% Span] / 28°C Range 2(DP&GP) ±[0.13% URL+0.12% Span] / 28°C Range 3-6(DP,GP,HS) ±[0.024% URL+0.045% Span] / 28°C HS7, AP3-5 ±[0.019% URL+0.125% Span]	Humidity Limits	5% ~ 100% RH		
		Process Temperature Limits	-40°C ~ +120°C		
		Power Supply Effects	±0.005% of Span per Volt		
Static Pressure Effects	Stability	Position Effect (90degree)	Zero Shift up to ±0.4 KPa		
				Mounting Position Effects	Zero Shift up to 400Pa No Span Effect
	Range 2	±0.25% of URL per 7MPa			
	Span	Range 3-6	±0.05% of URL per 7MPa		
		Range 1	±0.15% of reading per 0.7MPa		
Range 2		±0.4% of reading per 7MPa			
Range 3-6	±0.1% of reading per 7MPa				

### 4. Physical Specifications

Isolating Diaphragm	316L SST	Process Connection Size	1/4 - 18 NPT
Drain & Vent Valve	316 SST	(Adapter - Option)	1/2 - 14 NPT
Flange & Adapter	316 SST	Electrical Connections	1/2 - 14 NPT with M4
O-ring	Viton, PTFE	Weight (excluding Option Items)	3.51 Kg (Standard) 5 Kg(SST Housing)
Electronic Housing	Aluminum (Option:316L SST)	2" Pipe Stanchion Type bracket	Angle or Flat type
Bolts & Bolting Flange	304 SST	Housing Class	Waterproof (IP67), 4X





### Ordering Information

MODEL	Code	Description							
<b>APT3500 /APT3500N (Nuclear)</b>	-D	Differential Pressure Transmitter (Static Pressure 25MPa)							
	-HS	Differential Pressure Transmitter for High Line Pressure (Static Pressure 32MPa)							
	-G	Gauge Pressure Transmitter							
	-A	Absolute Pressure Transmitter							
<b>Ranges</b>		DP		GP		AP		HS	
		Calibrated Span(KPa)	Lower Range(KPa)	Calibrated Span(KPa)	Lower Range(KPa)	Calibrated Span(KPa)	Lower Range(KPa)	Calibrated Span(KPa)	Lower Range(KPa)
	1	0.0625 ~ 1.25	-1.25	0.0625 ~ 1.25	-1.25				
	2	0.15 ~ 7.5	-7.5	0.15 ~ 7.5	-7.5				
	3	0.65 ~ 65	-65	0.65 ~ 65	-65	2.5 ~ 250	0	0.65 ~ 65	-65
	4	2.5 ~ 250	-250	2.5 ~ 250	-100	15 ~ 1500	0	2.5 ~ 250	-250
	5	21 ~ 2100	-2100	21 ~ 2100	-100	25 ~ 2500	0	21 ~ 2100	-2100
	6	140 ~ 14000	-14000	140 ~ 14000	-100				
7							400 ~ 40000 (Gauge Only)	0	
X	Special								
<b>Mounting Flange /Material</b>		Body	Flange & Adapter	Vent Plug	Diaphragm				
	M11	316 SST	316 SST	316 SST	316L SST				
	M12	316 SST	316 SST	316 SST	HAST - C				
	M13	316 SST	316 SST	316 SST	Monel				
	M14	316 SST	316 SST	316 SST	Tantalum				
	*M21	316 SST	HAST - C	HAST - C	HAST - C				
	*M22	316 SST	HAST - C	HAST - C	Monel				
	*M23	316 SST	HAST - C	HAST - C	Tantalum				
<b>Hazardous Location Certifications</b>	K0	Maker Standard (Waterproof IP67)							
	K1	KCS Flameproof Approval			*K2	KCS Intrinsic Safety Approval			
	E1	ATEX(KEMA) Flameproof			*E2	ATEX(KEMA) Intrinsic Safety			
	*I1	IECEX Flameproof			*I2	IECEX Intrinsic safety			
	*F1	FM&FM Canada Explosion proof			*F2	FM&FM Canada Intrinsic Safety			
<b>Fill Fluid</b>	1	Silicone (DC200)			2	Inert fill fluid (Halocarbon oil)			
<b>Process Connection</b>	S	1/4 - 18 NPT (Standard)			O	1/2-14 NPT Female(Adapter)	X	Special	
<b>Electrical Connection</b>	1	1/2-14NPT Epoxy Polyester Painted Aluminum			2	G1/2-14 Epoxy-Polyester Painted Aluminum(Adapter)	X	Special	
<b>Option</b>	M1	LCD Indicator(5digit)							
	BC	Bottom Process Connection							
	LPI	Lightning Protector (Internal)			LPE	Lightning Protector (External)			
	K	Oil Free Finish							
	F1	Side Vent / Drain Top							
	F2	Side Vent / Drain Bottom							
	2W	2Way Manifold (SST) : Remote type			2WF	Flange type			
	3W	3 Way Manifold (SST) : Remote type			3WF	Flange type			
	5W	5Way Manifold (SST) : Remote type			5WF	Flange type			
	BA	Stainless Steel Bracket (Angle type) with SST Bolts							
	BF	Stainless Steel Bracket (Flat type) with SST Bolts							
	ST	Stainless Steel Housing							
T	Teflon O-Ring (Wetted Part)								
X	Special								

### Installation With Mounting Bracket

#### 2" Pipe Mounting Bracket Model Angle Type

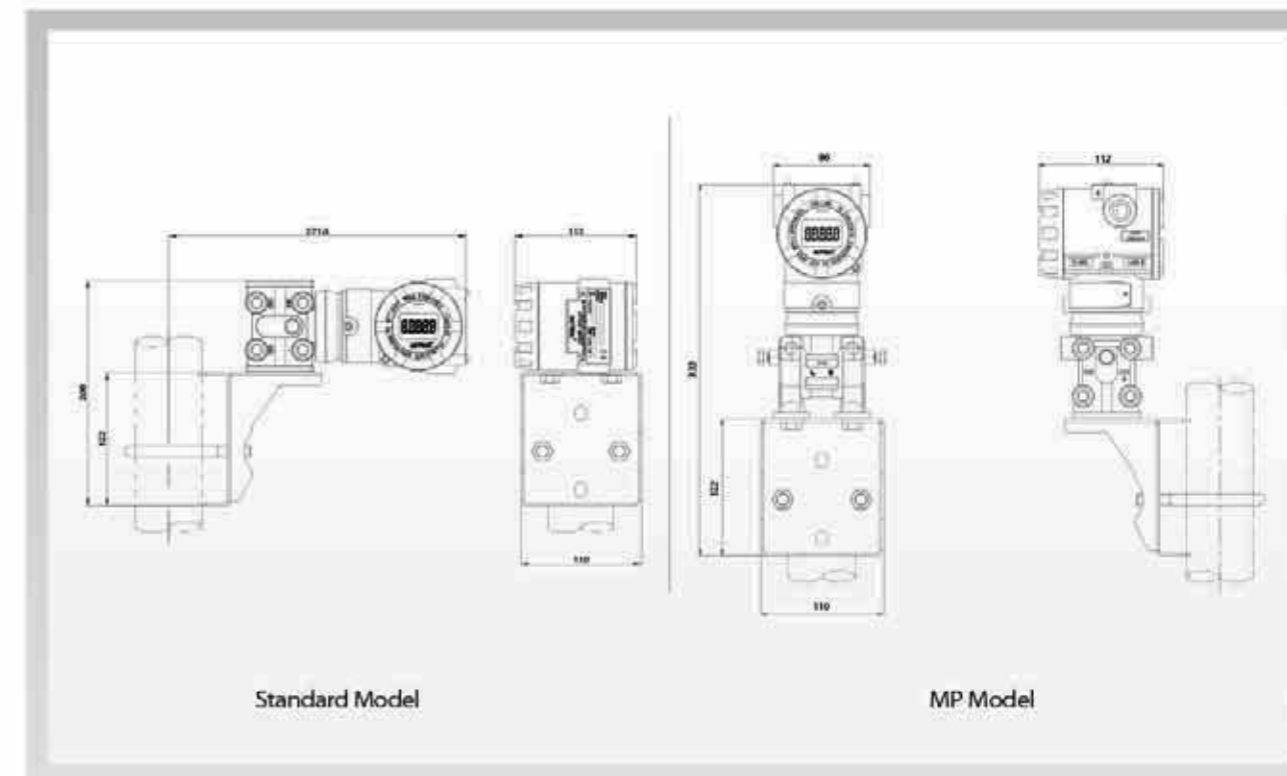

#### 2" Pipe Mounting Bracket Model Flat Type

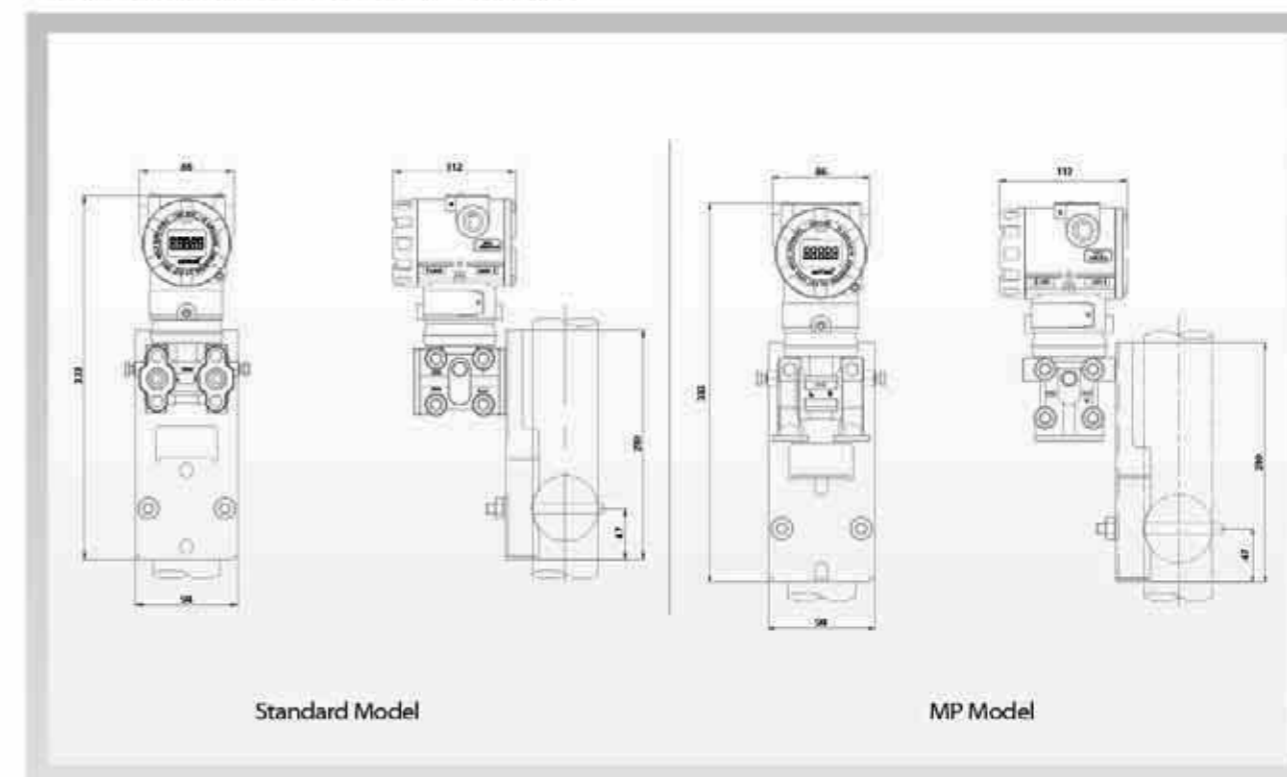

Example : APT3500-D5-M11-E1-1-S-1-M1-BA  
 Note 1 : Request to manufacturer for Draft Range, Absolute (small pressure and vacuum) and Items marked "\*" before order.

# Dimensions of Transmitter (mm)

# AUTROL®

## Standard Model

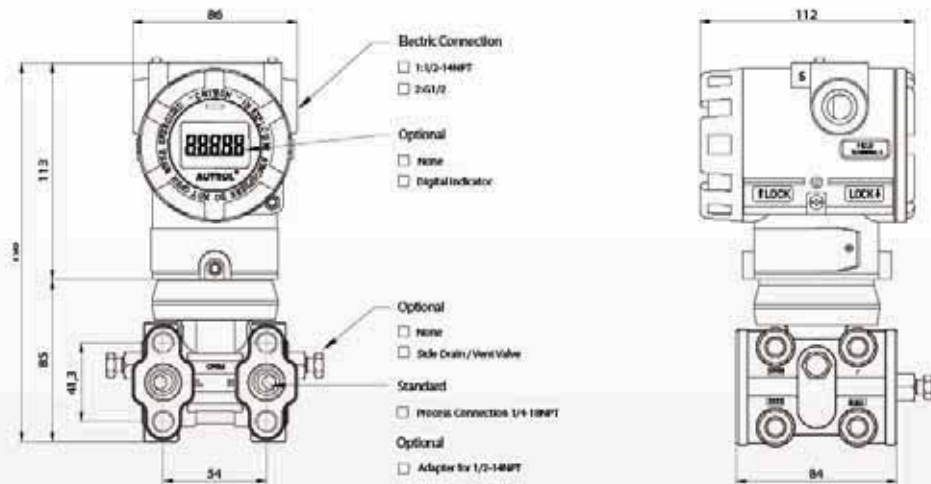

## High Static Pressure Model

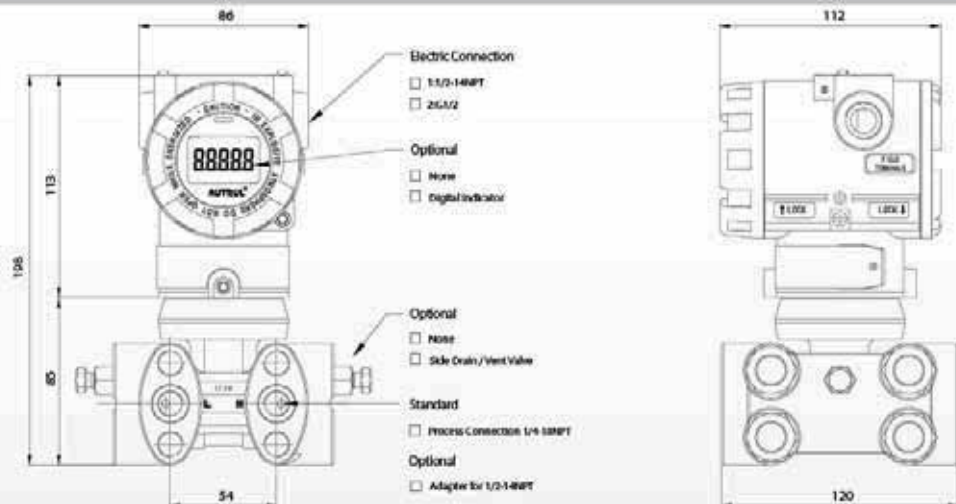

## Intrinsically safe Model

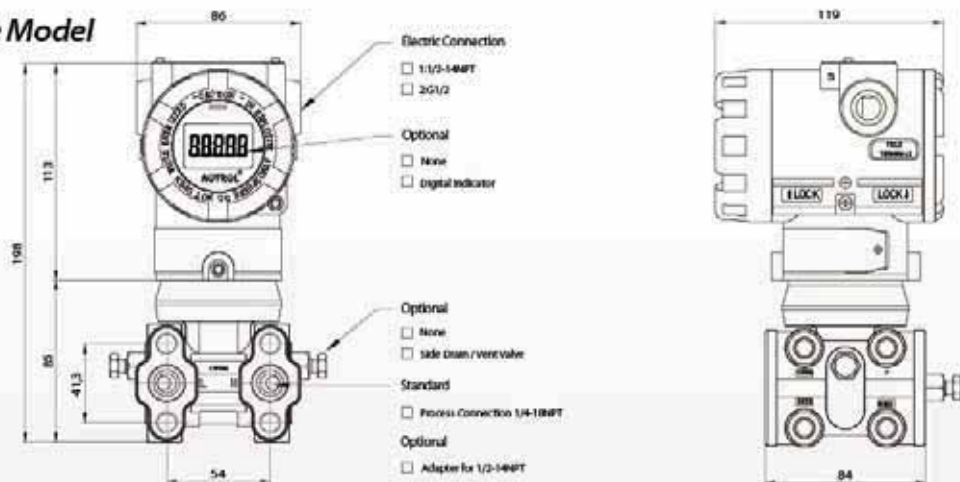

Duon System Co.,Ltd.

298-29, GONGDAN-RO, GUNPO-SI, GYEONGGI-DO, KOREA 15809  
 Tel: +82-31-389-6100 Fax: +82-31-429-7200 Web: www.autrol.com