

Remote reading thermometer

Model : T210

Spec. sheet no. TD02-01

Service intended

This thermometer is used for measuring temperature of corrosive and non-corrosive fluid in all industries. It operates in aggressive and non-aggressive environment. Linear dials and temperature compensate line assure an accurate temperature indication at varying ambient conditions.



Nominal diameter

100 and 150 mm

Accuracy

±2.0 % of full scale

Measuring system (SAMA class IIIB)

Organic gas : 0 ~ 200 °C

Inert gas : -200 ~ 700 °C

Working range

Maximum scale value



Standard features

Location of stem and mounting

Bottom connection, surface, case mounting
lower back connection, flush, case center mounting

Case

304SS

Cover

304SS

Capillary

Capillary : 1.6/0.2 mm, 316SS

Armored tube : 7.5/5.5 mm, 304SS

Window

Tempered safety glass

Dial

White aluminium with black graduation

Pointer

304SS, Black painted

Stem

8.0, 10.0 and 12.0 mm

316SS and 316L SS

Zero adjustment

Internal

Stem, process connection

3/8", 1/2", 3/4" PT, NPT and PF

Option

±1.0 % of full scale

WISE[®]

I T210_01

1. Base model**T210** Remote reading thermometer**2. Nominal diameter (mm)**

- 4** 100
6 150

3. Type of mounting

- B** Bottom connection, surface, case mounting plate
M Lower back connection, flush, case center mounting plate

4. Stem material

- 1** 316SS
2 316L SS

5. Stem, process connection

- A** None
D 3/8"
E 1/2"
F 3/4"

6. Stem connection type (CF: Compression fitting)

- A** None
E CF + PT
F CF + NPT
G CF + PF
H MT + PT (Movable thread)
I MT + NPT (Movable thread)
J MT + PF (Movable thread)

7. Stem outer diameter (mm)

- 2** 8.0
3 10.0
4 12.0
Z Other

8. Range**XXX** Refer to scale range table**9. Capillary length (m)**

- P** 2
Q 3
S 5
V 8
X 10
Z Other

10. Accessories

- 0** None
1 Thermowell
S Special accuracy (± 1.0 % of full scale)
T Thermowell and special accuracy

1	2	3	4	5	6	7	8	9	10
T210	4	B	1	E	C	2	XXX	P	1

Sample
ordering code

T210 : Type of mounting

Code B

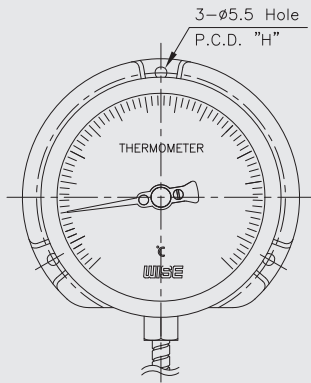

Code M

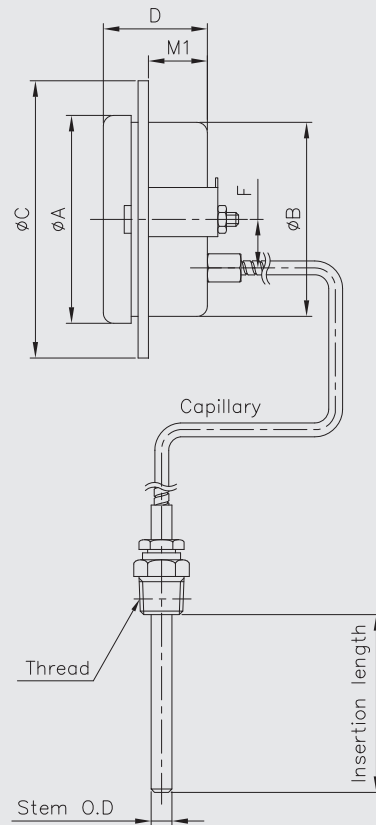
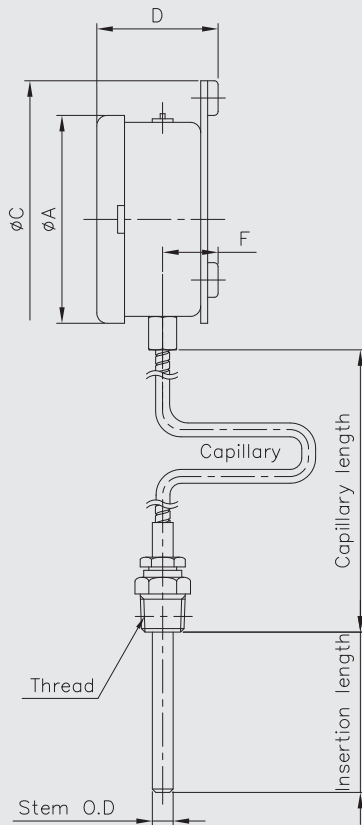
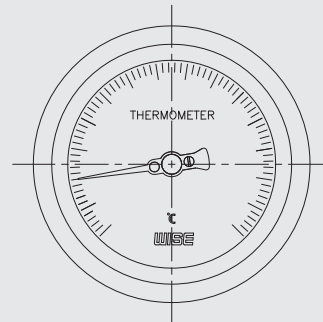

Dimensions (mm)

Dial Size	Available code	A	B	C	D±2	F±1	H	M1
100	B	111		128	53.5	18	115	
	M	111	99.5	128	50.5	30		28.5
150	B	169.5		178	66.5	25.5	165	
	M	169.5	153	178	63	55		38.5

Scale ranges

Code	Scale range (°C)	Scale spacing(°C)	Minimum stem length (mm)			Standard stem length (mm)		
			8.0	10.0	12.0	8.0	10.0	12.0
031	-200 ~ 100	5	100	85	65	200	130	100
032	-50 ~ 50	2	100	85	65	200	130	100
037	-50 ~ 100	2	100	88	65	200	130	100
054	-30 ~ 50	2	100	85	65	200	130	100
059	-30 ~ 100	2	100	85	65	200	130	100
061	-30 ~ 120	2	100	85	65	200	130	100
069	-20 ~ 50	2	100	85	65	200	130	100
074	-20 ~ 100	2	100	85	65	200	130	100
079	-20 ~ 150	5	100	85	65	200	130	100
084	-10 ~ 50	1	100	85	65	200	130	100
099	0 ~ 50	1	100	85	65	200	130	100
100	0 ~ 60	1	100	85	65	200	130	100
101	0 ~ 70	2	100	85	65	200	130	100
102	0 ~ 80	2	100	85	65	200	130	100
104	0 ~ 100	2	100	85	65	200	130	100
106	0 ~ 120	2	100	85	65	200	130	100
109	0 ~ 150	2	100	85	65	200	130	100
114	0 ~ 200	5	100	85	65	200	130	100
119	0 ~ 250	5	100	85	65	200	130	100
124	0 ~ 300	5	100	85	65	200	130	100
129	0 ~ 350	5	100	85	65	200	130	100
134	0 ~ 400	10	100	85	65	200	130	100
144	0 ~ 500	10	100	85	65	200	130	100
154	0 ~ 600	10	100	85	65	200	130	100
164	0 ~ 700	10	100	85	65	200	130	100

* 0 ~ 700 °C/Special range

* -200 ~ 100 °C/Special range

Insertion length

Code	1	2	3	4	5	6	7	8	9	A	B	C
Length (mm)	50	60	70	80	100	120	130	150	175	200	225	250

Code	D	E	F	G	H	J	K	L	M	N	P
Length (mm)	275	300	350	375	400	450	500	550	1,000	1,500	2,000