



ENVIROMAG 2000 Technical Datasheet

Electromagnetic Flow Sensor

- Engineered and manufactured for the North American water and wastewater industry
- NSF Approved for potable water
- Proven and unsurpassed lifetime performance
- Long-term reliability and durability
- Available IP68 rating
- Available for direct burial installation



KROHNE

Solution for the water & wastewater Industry

The **ENVIROMAG 2000** magmeter is the optimum solution for North American water and wastewater measurement applications. Its design and performance makes it the choice for flow measurement throughout the process.



1. Flanged design
2. PP, Polyurethane and Hard Rubber liner
3. 3/8" to 80" diameter
4. ANSI or AWWA flanges

Highlights

- Short inlet and outlet runs
- Unaffected by contamination, solids, fibers, slurries
- No maintenance
- Wet calibrated - includes calibration report
- Suitable for potable, chlorinated, fluorinated water, etc.
- Continuous self diagnostics
- NSF approved (Hard Rubber Liner)
- Available "virtual reference" eliminates grounding rings

Applications

- Wastewater processes
- Desalination processes
- Irrigation networks
- Clean water processes
- Water distribution
- Cooling stations - district heating

OPTIFLUX converters: All converters fit to all sensors



IFC 300 High-performance solution



IFC 100 Economical solution

Technical Data

Nominal diameter	VB14										VB15						VB16													
ASME [inch]	3/8"	1/2"	1"	1 1/4"	1 1/2"	2"	2 1/2"	3"	4"	5"	6"	8"	10"	12"	14"	16"	18"	20"	24"	28"	32"	36"	40"	48"	54"	56"	60"	64"	72"	80"
DN [mm]	10	15	25	32	40	50	65	80	100	125	150	200	250	300	350	400	450	500	600	700	800	900	1000	1200	1350	1400	1500	1600	1800	2000

Nominal Flange Pressure

ASME B16.5 - 150 lbs RF	[Standard Feature]																															
ASME B16.5 - 300 lbs RF	[Standard Feature]												[Optional Feature]																			
AWWA - class B FF	[Standard Feature]												[Optional Feature]																			
AWWA - class D FF	[Standard Feature]																															

> 8012000 mm on request (OPTIFLUX Series)

AWWA Class D flanges ≤ 150PSI

AWWA Class B flanges ≤ 50 PSI

Liner

Polypropylene	[Standard Feature]																															
Hardrubber	[Standard Feature]																															
Polyurethane	[Standard Feature]												[Optional Feature]																			

See pressure and temperature limits for various liners

Electrodes (Replaceable)

Stainless steel(AISI 316 L)	[Standard Feature]																															
Hastelloy C22	[Standard Feature]																															
Hastelloy C4	[Standard Feature]												[Optional Feature]																			

(Titanium, Tantalum, Platinum available on request)

Grounding rings

Virtual Reference [†]	[Standard Feature]																															
Hastelloy C4	[Standard Feature]												[Optional Feature]																			
Stainless steel 1,4571 (AISI 316 Ti)	[Standard Feature]																															

[†]Only with IFC300 Converter. Must specify option at time of order.

Materials

Measuring tube - austenitic stainless steel	[Standard Feature]																															
Housing	[Standard Feature]																															
Sheet steel (polyurethane coated)	[Standard Feature]																															
Stainless steel	[Standard Feature]												[Optional Feature]																			
Flanges	[Standard Feature]																															
Carbon Steel	[Standard Feature]																															
Stainless steel(AISI 316 L)	[Standard Feature]												[Optional Feature]																			
Stainless steel (AISI 304)	[Standard Feature]												[Optional Feature]																			
Connection box	[Standard Feature]																															
Die-cast aluminium (polyurethane coated)	[Standard Feature]																															
Stainless steel connection box	[Standard Feature]												[Optional Feature]																			

Protection category

IP 66 / 67 (NEMA 4/4X / 6)	[Standard Feature]																															
IP 68 (NEMA 6P [†])	[Standard Feature]												[Optional Feature]																			

Approvals

General Purpose	[Standard Feature]																															
CSA - Ordinary Locations	[Standard Feature]												[Optional Feature]																			

Please note the approvals are for flow sensors only.

Versions

Compact + IFC 300 C	[Standard Feature]																															
Separate + IFC 300 F, R, W	[Standard Feature]																															
Compact + IFC 100 C	[Standard Feature]																								[Optional Feature]							
Separate + IFC 100 W	[Standard Feature]																															

Conductivity

Min. conductivity	min. 20 µS/cm																															
-------------------	---------------	--	--	--	--	--	--	--	--	--	--	--	--	--	--	--	--	--	--	--	--	--	--	--	--	--	--	--	--	--	--	--

[†]Separate Only with Stainless Steel Junction Box

[Blue Box] Standard Feature

[Grey Box] Optional Feature

Temperature Range

Temperature range [°C]	Process [°C]		Ambient [°C]	
	min.	max.	min.	max.

Hardrubber

Separate flow sensor (2000 F)	-5	80	-40	65
Compact with IFC 300 (2300 C)	-5	80	-40	65
Compact with IFC 100 (2100 C)	-5	80	-25	60

* Hard Rubber available for sizes DN25 - 2000

Polyurethane

Separate flow sensor (2000 F)	-5	69	-40	65
Compact with IFC 300 (2300 C)	-5	69	-40	65
Compact with IFC 100 (2100 C)	-5	69	-25	60

* Polyurethane available for DN 50-1000

Polypropylene

Separate flow sensor (2000 F)	-5	90	-40	65
Compact with IFC 300 (2300 C)	-5	90	-40	65
Compact with IFC 100 (2100 C)	-5	90	-25	60

* Polypropylene available for DN 10-15

Temperature range [°F]	Process [°F]		Ambient [°F]	
	min.	max.	min.	max.

Hardrubber

Separate flow sensor (2000 F)	23	176	-40	149
Compact with IFC 300 (2300 C)	23	176	-40	149
Compact with IFC100 (2100 C)	23	176	-13	140

* Hard Rubber available for sizes 1" - 80"

Polyurethane

Separate flow sensor (2000 F)	23	156	-40	149
Compact with IFC 300 (2300 C)	23	156	-40	149
Compact with IFC 100 (2100 C)	23	156	-13	140

* Polyurethane available for sizes 2" - 40"

Polypropylene

Separate flow sensor (2000 F)	23	194	-40	149
Compact with IFC 300 (2300 C)	23	194	-40	149
Compact with IFC 100 (2100 C)	23	194	-13	140

* Polypropylene available for ASME 3/8" - 1/2"

Vacuum Load

Liner	Diameter [mm]	Minimum operating pressure absolute in mbar (abs) at process temperature			
		20°C	40°C	60°C	80°C
Polypropylene Hardrubber and Polyurethane	DN 10 - 15	250	250	400	400
	DN 25 - 300	250	250	400	400 ¹
	DN 350 - 1000	500	500	600	600 ¹
	DN 1200 - 2000	600	600	750	750 ¹

Liner	Diameter [inch]	Minimum operating pressure absolute in psia at process temperature			
		68°F	104°F	140°F	176°F
Polypropylene Hardrubber and Polyurethane	3/8" - 1/2"	3.6	3.6	5.8	5.8
	1" - 12"	3.6	3.6	5.8	5.8 ¹
	14" - 40"	7.3	7.3	8.7	8.7 ¹
	48" - 80"	8.7	8.7	10.9	10.9 ¹

¹Notes: Not applicable to Polyurethane liner, exceeds process temperature limit.

ENVIROMAG Flow Sensor Dimensions and Weights

Refer to diagrams on page 7

Nominal size [inch-mm]	Flange Type/ Rating	Dimensions [mm]			Dimensions [inch]			Approximate weight	
		L ¹	H	W	L ¹	H	W	[kg]	[lb]
3/8" - 10	ANSI 150	150	179	89	5.9	7.1	3.5	7	16.0
1/2" - 15	ANSI 150	150	179	89	5.9	7.1	3.5	7	16.0
1" - 25	ANSI 150	150	179	108	5.9	7.1	4.3	8	18.0
1½" - 40	ANSI 150	150	203	127	5.9	8.0	5.0	10	22.0
2" - 50	ANSI 150	200	191	152	7.9	7.5	6.0	13	29.0
3" - 80	ANSI 150	200	210	191	7.9	8.3	7.5	17	37.0
4" - 100	ANSI 150	250	256	229	9.8	10.1	9.0	23	51.0
5" - 125	ANSI 150	250	280	254	9.8	11.0	10.0	27	60.0
6" - 150	ANSI 150	300	304	279	11.8	12.0	11.0	34	75.0
8" - 200	ANSI 150	350	355	343	13.8	14.0	13.5	50	110.0
10" - 250	ANSI 150	400	433	406	15.8	17.1	16.0	73	160.0
12" - 300	ANSI 150	500	499	483	19.7	19.7	19.0	100	220.0
14" - 350	ANSI 150	500	552	533	19.7	21.7	21.0	114	250.0
16" - 400	ANSI 150	600	608	597	23.6	23.9	23.5	155	340.0
18" - 450	ANSI 150	600	672	635	23.6	26.5	25.0	170	375.0
20" - 500	ANSI 150	600	739	699	23.6	29.1	27.5	191	420.0
24" - 600	ANSI 150	600	852	813	23.6	33.5	32.0	250	550.0
28" - 700	AWWA CL D	700	918	927	27.6	36.1	36.5	320	704.0
30" - 750	AWWA CL D	750	974	984	29.5	38.3	38.8	358	787.6
32" - 800	AWWA CL D	800	1038	1060	31.5	40.9	41.8	395	869.0
36" - 900	AWWA CL D	900	1144	1168	35.4	45.0	46.0	450	990.0
40" - 1000	AWWA CL D	1000	1258	1289	39.4	49.5	50.8	665	1463.0
42" - 1050	AWWA CL D	1300	1313	1350	51.2	51.7	53.1	683	1502.6
48" - 1200	AWWA CL D	1300	1483	1511	51.2	58.4	59.5	970	2134.0
54" - 1350	AWWA CL D	1600	1635	1682	63.0	64.4	66.2	TBA	TBA
60" - 1500	AWWA CL D	1700	1782	1860	66.9	70.2	73.2	TBA	TBA
70" - 1750	AWWA CL D	1800	2139	2197	70.9	84.2	86.5	TBA	TBA

Nominal size [inch-mm]	Flange Type/ Rating	Dimensions [mm]			Dimensions [inch]			Approximate weight	
		L ¹	H	W	L ¹	H	W	[kg]	[lb]
1" - 25	ANSI 300	150	145	124	5.9	5.7	4.9	8	18.0
1½" - 40	ANSI 300	200	169	156	7.9	6.7	6.1	9	20.0
2" - 50	ANSI 300	250	186	165	9.8	7.3	6.5	13	29.0
3" - 80	ANSI 300	250	214	210	9.8	8.4	8.3	17	37.0
4" - 100	ANSI 300	300	275	254	11.8	10.8	10.0	23	51.0
6" - 150	ANSI 300	350	316	318	13.8	12.4	12.5	36	79.0
8" - 200	ANSI 300	400	382	381	15.8	15.0	15.0	71	157.0
10" - 250	ANSI 300	500	448	445	19.7	17.6	17.5	112	247.0
12" - 300	ANSI 300	600	519	521	23.6	20.4	20.5	170	375.0
14" - 350	ANSI 300	700	595	584	27.6	23.4	23.0	215	474.0
16" - 400	ANSI 300	800	646	648	31.5	25.4	25.5	290	639.0
18" - 450	ANSI 300	800	709	711	31.5	27.9	28.0	359	789.0
20" - 500	ANSI 300	800	777	775	31.5	30.6	30.5	426	937.0
24" - 600	ANSI 300	800	903	914	31.5	35.5	36.0	611	1345.0

Notes:

¹ If flowmeter is supplied with separate grounding rings, the total fitting length "L" is computed as follows: "L" + 2 x 3 mm (1/8") + 2 x gasket thickness

Add 2kg/4.5lb for compact IFC100 Converter

Add 4.2kg/9.3 lb for compact IFC300 converter

Dimensions and weight

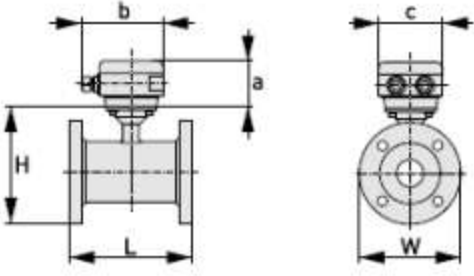
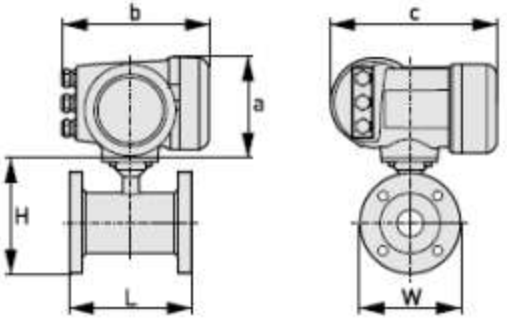
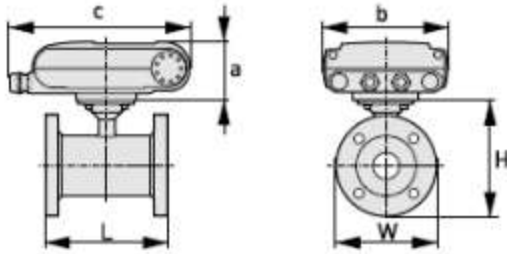
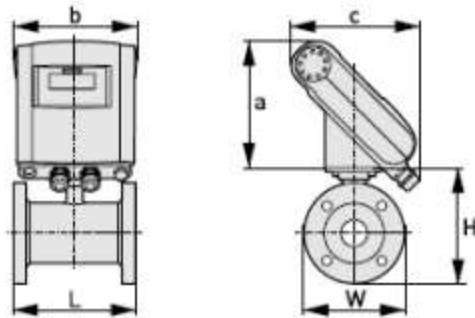
<p>Remote version</p>		<p>$a = 77 \text{ mm} / 3.1''$ $b = 139 \text{ mm} / 5.5''$ ① $c = 106 \text{ mm} / 4.2''$ Total height = $H + a$</p>
<p>Compact version with IFC 300</p>		<p>$a = 155 \text{ mm} / 6.1''$ $b = 230 \text{ mm} / 9.1''$ ① $c = 260 \text{ mm} / 10.2''$ Total height = $H + a$</p>
<p>Compact version with IFC 100 (0°)</p>		<p>$a = 82 \text{ mm} / 3.2''$ $b = 161 \text{ mm} / 6.3''$ $c = 257 \text{ mm} / 10.1''$ ① Total height = $H + a$</p>
<p>Compact version with IFC 100 (45°)</p>		<p>$a = 186 \text{ mm} / 7.3''$ $b = 161 \text{ mm} / 6.3''$ $c = 184 \text{ mm} / 7.3''$ ① Total height = $H + a$</p>

① The value may vary depending on the used cable glands.

- All data given in the following tables are based on standard versions of the sensor only.
- Especially for smaller nominal sizes of the sensor, the converter can be bigger than the sensor.
- Note that for other pressure ratings than mentioned, the dimensions may be different.
- For full information on converter dimensions see relevant documentation.

KROHNE Product Overview

- Electromagnetic flowmeters
- Variable area flowmeters
- Mass flowmeters
- Ultrasonic flowmeters
- Vortex flowmeters
- Flow controllers
- Level measuring instruments
- Pressure gauges
- Temperature measuring instruments
- Water solutions & analysis
- Oil and gas turnkey solutions

KROHNE, Inc.
7 Dearborn Road
Peabody, MA, 01960 (USA)
1-800-FLOWING (978 535-6060)
www.krohne.com/northamerica
info@krohne.com

KROHNE