



GA24 Technical Datasheet

Variable-area flowmeter

- Sturdy construction for several applications
- Local indication without auxiliary power
- Replaceable mounting parts



1	Product features	3
1.1	GA24 Variable area flowmeter	3
1.2	Operating principle	4
2	Technical data	5
2.1	Technical data	5
2.2	Dimensions and weights	8
2.3	Measuring ranges	9
3	Installation	11
3.1	Intended use	11
3.2	Installation conditions	11
4	Electrical connections	12
4.1	Limit switches GA24	12
4.1.1	MS14 limit switch connection	13
4.1.2	TG21 limit switch connection	13
5	Order form	14
6	Notes	15

1.1 GA24 Variable area flowmeter

The GA24 flowmeter is designed for measuring the volume or mass flow rate of liquids and gases and for measuring gases at low operating pressures.



Highlights

- Universal installation length concept
- Low pressure loss in gas applications
- Low maintenance
- Optional limit switch
- Quick and easy to install and operate
- Easy feeding of suspended solid particle (can also be installed at a later date)
- Fragment protection

Industries

Can be used in all industrial sectors,
for example

- Chemicals
- Heating, Ventilation & Air Conditioning (HVAC)
- Iron, Steel & Metals
- Oil and Gas
- Power plants
- Machinery
- Paper and Pulp
- Water
- Furnace construction

Applications

- Gas measurements
- Industrial burner controlling
- Compressor monitoring
- Water circuits

1.2 Operating principle

The flowmeter operates on the float measuring principle.

The measuring unit consists of a glass cone in which a float can move freely up and down.

The flow goes from bottom to top.

The float changes position so that the lifting force acting on it F_1 is in equilibrium with the form drag F_2 and its weight F_3 : $F_3 = F_1 + F_2$

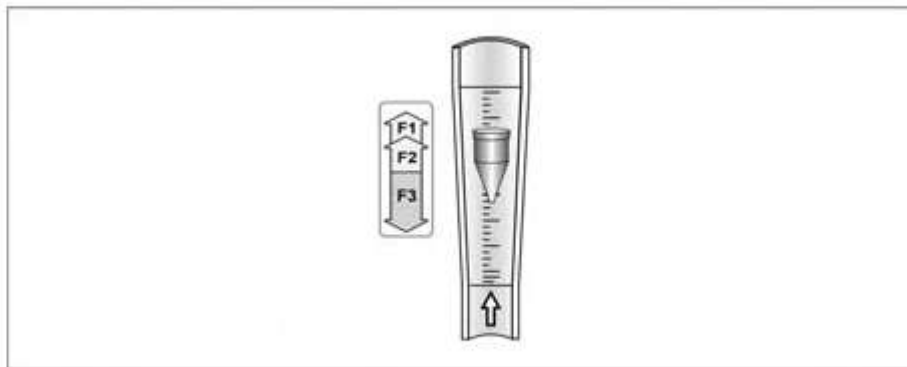

The height of the float is read on the scale of the measuring glass and indicates the flow rate.

The top edge of the float marks the reading line for flow values.

2.1 Technical data

- The following data is provided for general applications. If you require data that is more relevant to your specific application, please contact us or your local representative.
- Additional information (certificates, special tools, software,...) and complete product documentation can be downloaded free of charge from the website (Download Center).

Measuring system

Application range	Flow measurement of liquids, gases and vapors
Operating method / measuring principle	Variable area measuring principle
Measured value	
Primary measured value	Float position
Secondary measured value	Operating and standard volumetric flow
Measuring accuracy	
Directive	VDI / VDE 3513, sheet 2 (q _G =50%)
Measuring accuracy	1.0%

Operating conditions

Temperature	
Max. operating temperature TS	-40...+120°C / -40...+248°F
Pressure	
Max. permitted operating gauge pressure PS at TS = 100°C	Pressure equipment directive 97/23/EC
Test pressure PT	Pressure equipment directive 97/23/EC or AD 2000-HP30
DN15, DN25	10 bar ①
DN40	9 bar ①
DN50	7 bar ①

Installation conditions

Inlet condition, run	≥ 5 x DN
Outlet condition, run	≥ 3 x DN

① other pressures upon request

Materials

Flange connection GA24/R	Stainless steel 1.4404 (316 L)
Flange connection GA24/PTFE	Stainless steel 1.14404 (316 L) with a liner made of PTFE
Housing	Steel plate housing (zinc-plated with epoxy/polyester coating)
Measuring cone	Borosilicate glass
Suspended solid particle	Stainless steel 1.4571 (316 Ti) or Hastelloy C2000
	PTFE/insert or TFM (PTFE)
	Aluminum
	Polypropylen (PP)
Suspended solid particle and insert	PVDF (conforms to FDA)
Seals	Neoprene
	PTFE Scherring
	PTFE sleeve

Temperatures

For devices to be used in hazardous areas, special temperature ranges apply. These can be found in the separate instructions.

Max. measuring temperature T_m	-40...+120°C ①	-40...+248°F
Max. ambient temperature $T_{amb.}$	-20...+100°C	-4...+212°F

① higher temperatures on request

Types of limit switches

Type	Switching function	Connection	Shape	Note
MS 14/A	bistable	2-wire, floating	Reed contact	Float with magnet required
TG 21	bistable	2-wire NAMUR	Slotted proximity switch	Float with magnet required

Limit switch use

Size	Cone no.	Limit switch	Size	Cone no.	Limit switch	
DN15	N 18.07	MS14/A	DN25	N 21.09	MS14/A	TG21
	N 18.09	MS14/A		N 21.13	MS14/A	TG21
	N 18.13	MS14/A		N 21.18	MS14/A	TG21
	N 19.09	MS14/A		N 21.25	MS14/A	TG21
	N 19.13	MS14/A	DN40	N 41.09	MS14/A	TG21
	N 19.19	MS14/A		N 41.13	MS14/A	TG21
	N 19.26	MS14/A		N 41.19	MS14/A	TG21
			DN50	N 51.10	MS14/A	TG21
				N 51.15	MS14/A	TG21
				N 51.21	MS14/A	TG21

Technical Data Limit Switches

Technical data MS14

Contact type	Normally open or normally closed, can be reconnected
Switching reproducibility	< 2% of full-scale range
Contact rating	12VA
max. turn-on voltage	30VDC
Max. switching current	0,5A
Ambient temperature	-20...+85°C / -4...+185 °F
Protection category acc. to IEC 60529 / EN 529	IP44

Technical data TG21

Rated voltage	8VDC
Current consumption, active surface open	3mA
Current consumption, active surface covered	1mA
Ambient temperature	-25...+100°C / -13...+212 °F
Protection category acc. to IEC 60529 / EN 529	IP 67 (NEMA 6)

2.2 Dimensions and weights

Dimensions

Nominal size		a		b		c		d	
DN	Inch	mm	Inch	mm	Inch	mm	Inch	mm	Inch
15	1/2"	500	19.7	300	11.8	84	3.31	82	3.23
25	1"	500	19.7	300	11.8	105	4.13	102	4.02
40	1 1/2"	500	19.7	300	11.8	125	4.92	122	4.80
50	2"	500	19.7	300	11.8	165	6.50	147	5.74

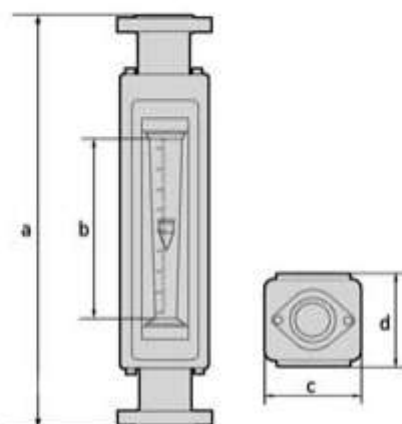

Weights

	approx. kg	approx. lb
DN15	6	13
DN25	10	22
DN40	13	29
DN50	18	40

Process connection

	Connection dimensions according to	Connection	Pressure class
Flanged connections	EN 1092	DN15, DN25	PN25
	EN 1092	DN40 DN50	PN10
	ASME B16.5	1/2" ...2"	Class 150 lb / RF
	ASME B16.5	1/2" ...2"	Class 300 lb / RF

2.3 Measuring ranges

Measuring span 10 : 1	Flow values 100%
Reference condition:	Water 20°C / Air 20°C - 1.013 bar abs.
Float materials:	1 Stainless Steel or Hastelloy® - 2 PTFE - 3 TFM - 4 Aluminium - 5 Polypropylen (PP)

Materials →		1	2	3	1	3	4	5	1	2	3	4	5
Cone ↓		Flow water [l/h]			Flow air [m ³ /h]				Max. pressure loss [mbar]				
N 18.07	DN15	40	25	13	1.5	0.6	0.8	0.5	9	6	2	3	1
N 18.09		63	40	22	2.2	0.95	1.2	0.7	9	7	3	3	2
N 18.13		100	63	35	3	1.5	1.8	1.2	9	8	3	4	2
N 19.09		160	100	55	5	2.2	2.8	1.8	13	9	4	5	2
N 19.13		250	160	85	8	3.3	4.5	2.8	16	11	4	5	2
N 19.19		400	250	140	-	-	-	-	21	14	5	-	-
N 19.26		630	400	230	-	-	-	-	27	17	6	-	-
N 21.09	DN25	630	400	230	18 ①	9	11	7	22	14	6	8	3
N 21.13		1000	630	350	28 ①	14	18	12	23	17	6	8	4
N 21.18		1600	1000	600	49 ①	-	28 ①	17 ①	26	25	7	10	6
N 21.25		2500	1600	950	70 ①	-	42 ①	26 ①	33	40	8	12	9
N 41.09	DN40	1600	1000	600	45 ①	22	28	18	32	18	9	11	5
N 41.13		2500	1600	900	70 ①	36	45 ①	28 ①	34	20	10	12	5
N 41.19		4000	2500	1500	128 ①	-	76 ①	46 ①	38	24	11	15	8
N 51.10	DN50	4000	2500	1500	120 ①	56	70	45	43	25	12	15	7
N 51.15		6300	4000	2400	190 ①	90	110 ①	70 ①	47	30	13	16	7
N 51.21		10000	6300	3500	310 ①	-	170 ①	118 ①	55	42	14	20	10

① only possible with guided float

The operating pressure should be at least double the pressure loss for liquids and five times for gases. The indicated pressure losses are valid for water and air at maximum flow rate. Conversion to other products or operating data is performed by KROHNE using the calculation method stipulated by VDI/VDE Directive 3513.

Measuring span 10 : 1	Flow values 100%
Reference condition:	Water 68°F / Air 68°F - 14.7 psi
Float materials:	1 Stainless Steel or Hastelloy® - 2 PTFE - 3 TFM - 4 Aluminium - 5 Polypropylen (PP)

Materials →		1	2	3	1	3	4	5	1	2	3	4	5
Cone ↓		Flow, water [gph]			Flow, air [scfm]				Max. pressure loss [psi]				
N 18.07	DN15	10.6	6.6	3.43	0.93	0.37	0.5	0.31	0.1	0.1	0.03	0.04	0.02
N 18.09		16.6	10.6	5.81	1.36	0.59	1.2	0.43	0.1	0.1	0.04	0.04	0.03
N 18.13		26.4	16.6	9.25	1.86	0.93	0.74	0.74	0.1	0.1	0.04	0.06	0.03
N 19.09		42.3	26.4	14.5	3.1	1.36	1.7	1.1	0.19	0.13	0.06	0.07	0.03
N 19.13		66.0	42.3	22.5	4.96	2.05	2.8	1.7	0.2	0.16	0.06	0.07	0.03
N 19.19		105	66.0	37	-	-	-	-	0.3	0.2	0.07	-	-
N 19.26		166	106	60.8	-	-	-	-	0.4	0.25	0.09	-	-
N 21.09	DN25	166	106	60.8	11.2 ①	5.58	6.8	4.3	0.3	0.2	0.09	0.1	0.06
N 21.13		264	166	92.5	17.4 ①	8.68	11	7.4	0.3	0.25	0.09	0.1	0.06
N 21.18		423	264	158	30.4 ①	-	17 ①	10.5 ①	0.3	0.3	0.1	0.15	0.9
N 21.25		660	423	251	43.4 ①	-	26 ①	16 ①	0.48	0.58	0.1	0.17	0.13
N 41.09	DN40	423	264	158	27.9 ①	13.6	17	11	0.48	0.26	0.1	0.16	0.07
N 41.13		660	423	238	43.4 ①	22.3	28 ①	17.4 ①	0.49	0.29	0.15	0.17	0.07
N 41.19		1057	660	396	79.4 ①	-	47 ①	28.5 ①	0.55	0.35	0.16	0.22	0.1
N 51.10	DN50	1057	660	396	74.4 ①	34.7	43.4	27.9	0.62	0.36	0.17	0.22	0.1
N 51.15		1664	1057	634	118 ①	55.8	68 ①	43.4 ①	0.68	0.44	0.19	0.23	0.1
N 51.21		2642	1664	925	192 ①	-	105 ①	73 ①	0.8	0.61	0.2	0.29	0.15

① only possible with guided float

The operating pressure should be at least double the pressure loss for liquids and five times for gases. The specified pressure losses are valid for water and air at maximum flow rate. Conversion to other products or operating data is performed by KROHNE using the calculation method stipulated in VDI/VDE Directive 3513.

3.1 Intended use

The variable area flowmeters are suitable for measuring gases and liquids.

The devices are particularly suitable for the measurement of:

- Liquids
- Hydrocarbons
- Water
- Chemicals with low corrosiveness
- Industrial gases

For devices used in hazardous areas, additional safety notes apply; please refer to the Ex documentation.

Responsibility for the use of the measurement devices with regard to suitability, intended use and corrosion resistance of the used materials against the measured fluid lies solely with the operator.

The manufacturer is not liable for any damage resulting from improper use or use for other than the intended purpose.

Do not use any abrasive or highly viscous media.

3.2 Installation conditions

When installing the device in the piping, the following points must be observed:

- *The variable area flowmeter must be installed vertically (measuring principle). Flow direction from bottom to top. For installation recommendations please refer also to VDI/VDE 3513 Sheet 3.*
- *Before connecting, blow or flush out the pipes leading to the device.*
- *Pipes for gas flow need to be dried before the device is installed.*
- *Use connectors suitable for the particular device version.*
- *Align the pipes centrically with the connection bores on the measuring device so they are free of stresses.*
- *If necessary, support the pipeline to reduce vibrations being transmitted to the measuring device.*
- *Do not lay signal cables directly next to cables for the power supply.*

4.1 Limit switches GA24

The flowmeters GA24 can be equipped with a maximum of two bistable limit switches.

Bistable function: Stable switching when passing through the switching point

Use, selection and function - see Technical Data

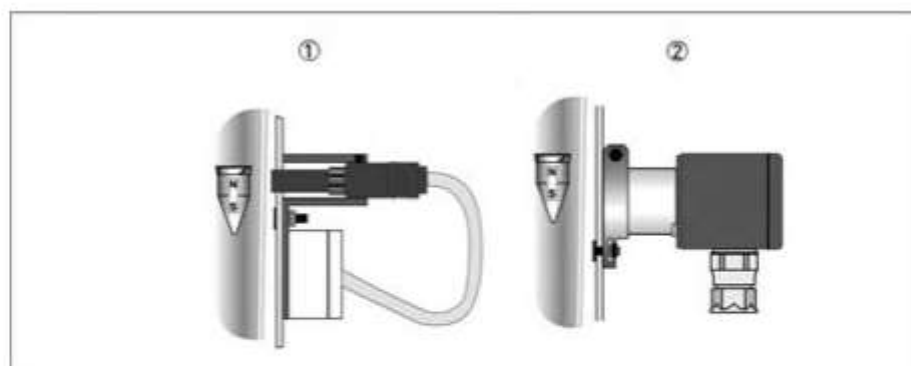

Figure 4-1: Types of limit switch

- ① MS 14/1 - floating, bistable reed contact
- ② TG21 - bistable, with integrated switching lug and slotted proximity switch

4.1.1 MS14 limit switch connection

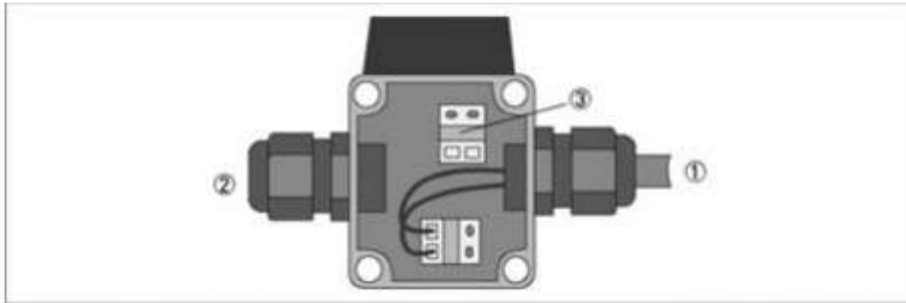

Figure 4-2: Connection limit switch type MS14

- ① Connection Reed-switch
- ② Connection Receiver device
- ③ Terminal connection (potential-free)

The switching function requires a float with integrated magnet.

4.1.2 TG21 limit switch connection

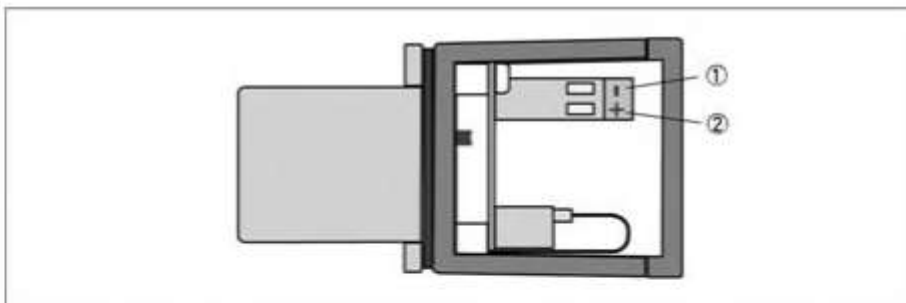

Figure 4-3: Connection limit switch type TG21

- ① Terminal -
- ② Terminal +

The TG 21 is adapted for switch amplifiers with an intrinsically safe circuit as per DIN EN 50227 NAMUR.

The TG 21 includes an inductive slotted proximity switch with bistable switching characteristics. The slotted proximity switch is activated by the immersion of an aluminum lug. The magnet of the immersion lug is moved by the magnet in the float.

The switching function requires a float with integrated magnet.

Please provide us with the missing information so that we can be of help to you as quickly as possible.

Then please fax this page to the appropriate sales associate. We will then contact you as soon as possible.

Device data

Connection type:	<input type="checkbox"/> EN 1092	<input type="checkbox"/> ASME B16.5
Pressure rating:		
Limit switch:	<input type="checkbox"/> K1 ① <input type="checkbox"/> K2 ②	
Approval:	<input type="checkbox"/> Disable	<input type="checkbox"/> ATEX

① 1 limit switch

② 2 limit switches

Rating data

Product:			
Operating pressure:		<input type="checkbox"/> Absolute pressure	<input type="checkbox"/> Overpressure
Rated pressure:			
Operating temperature:			
Rated temperature:			
Density:		<input type="checkbox"/> Standard density	<input type="checkbox"/> Operating density
Viscosity:			
Measuring range:			
Comments:			

Contact data

Company:	
Contact person:	
Telephone number:	
Fax number:	
E-mail:	

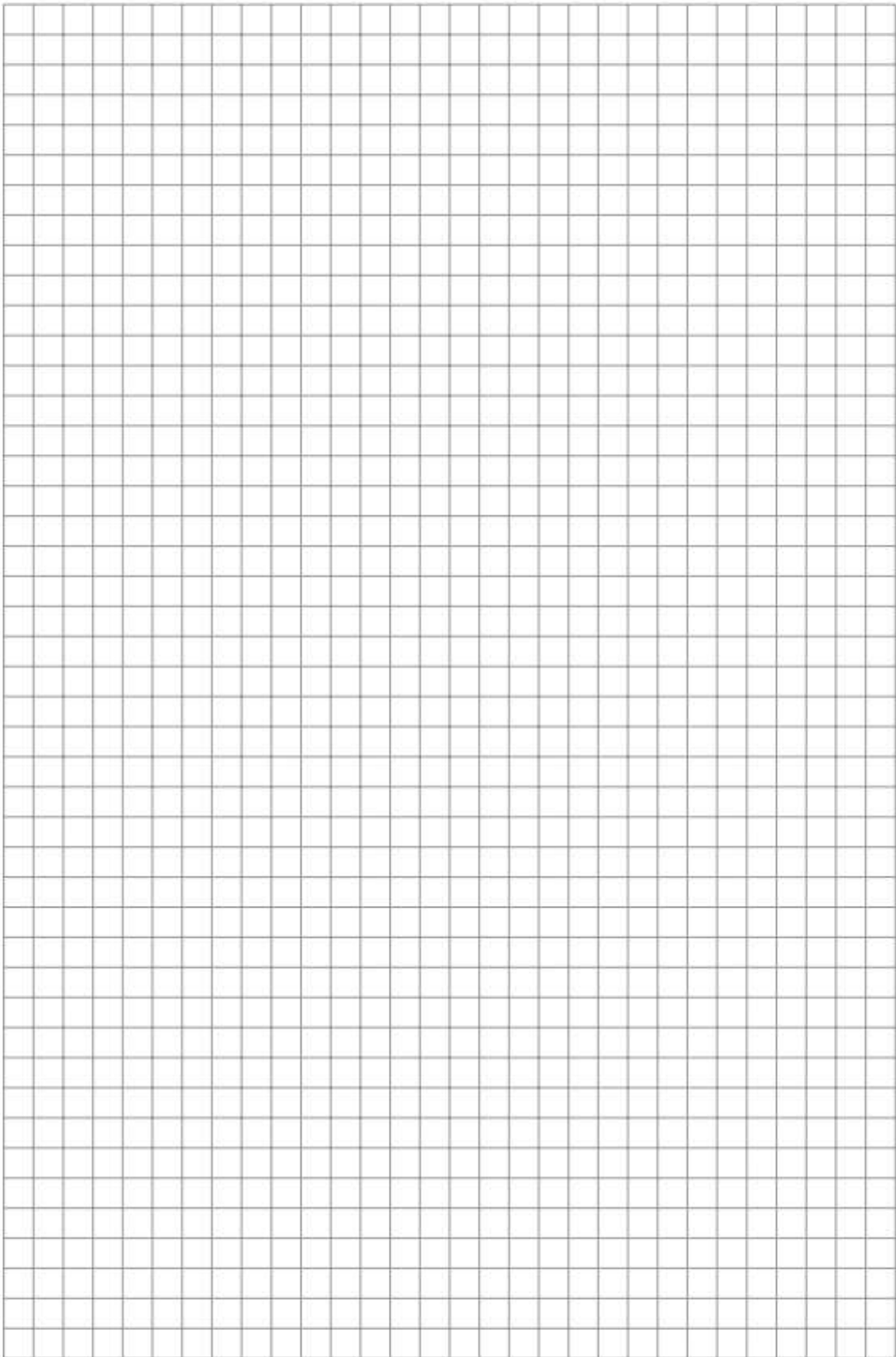



KROHNE product overview

- Electromagnetic flowmeters
- Variable area flowmeters
- Ultrasonic flowmeters
- Mass flowmeters
- Vortex flowmeters
- Flow controllers
- Level meters
- Temperature meters
- Pressure meters
- Analysis products
- Measuring systems for the oil and gas industry
- Measuring systems for sea-going tankers

Head Office KROHNE Messtechnik GmbH
Ludwig-Krohne-Str. 5
D-47058 Duisburg (Germany)
Tel.: +49 (0)203 301 0
Fax: +49 (0)203 301 10389
info@krohne.de

The current list of all KROHNE contacts and addresses can be found at:
www.krohne.com

KROHNE