

Electrical contact pressure gauge with aluminium case

Model: P531, P532, P533, P534, P537, P539 series

Spec. sheet no. PD05-05

Service intended

P530 series are designed for a local reading of measured pressure and equipped with the inductive contact block which allows all the combinations of contacts to be used. The contact block is mounted on the dial. The window is fitted with a knob for external adjustment of the setpoints.



Nominal diameter

100 and 150 mm

Accuracy

±1.5 % of full scale

Scale range (MPa, kPa, bar)

-0.1 ~ 0 to -0.1 ~ 2 MPa

0 ~ 0.1 to 0 ~ 100 MPa

Working pressure

Steady : 75 % of full scale

Over range protection : 130 % of full scale

Working temperature

Ambient : -40 ~ 65 °C

Fluid : Max. 100 °C

Temperature effect

Accuracy at temperature above and below the reference temperature (20 °C) will be effected by approximately ±0.4 % per 10 °C of full scale



Standard features

Pressure connection

Stainless steel (316SS)

Element

C type bourdon tube

Stainless steel (316SS)

Case

Black finished aluminium

Cover

Black finished aluminium

Screwed

Window

Acrylic resin

Safety glass (P539)

Movement

Stainless steel

Dial

White aluminium with black graduations

Pointer

BsT3 alloy, black painted pointer with golden plated

Contacts

Contact rating : AC 110 V, 0.5 A/AC 220 V 0.25 A

DC 110 V, 0.3 A/DC 220 V 0.15 A

Dielectric strength : AC 1,000 V/min

Insulation resistance : More than 100 MΩ at DC 500 V

Process connection

3/8", 1/2" PT, NPT and PF

Certificates

Pressure equipment directive (2014/68/EU) Annex III Module H

WISE[®]

| P530 Series_01

1. Base model

- P531** High alarm contact type pressure gauge
P532 High and low alarm contact type pressure gauge
P533 Low alarm contact type pressure gauge
P534 Two high alarm contact type pressure gauge
P537 Two low alarm contact type pressure gauge
P539 Multi-purpose contact type pressure gauge
 for transformer, only available with diameter 100 mm

2. Nominal diameter

- 4** 100 mm
6 150 mm, not available with model P539 series

3. Type of mounting

- A** Bottom connection, direct
B Bottom connection, surface, case mounting plate,
 not available with diameter 150 mm
G Lower back connection, direct, only available with
 diameter 150 mm and model P539
L Lower back connection, flush, case center mounting
 plate, not available with diameter 150 mm
M Lower back connection, flush, cover center mounting
 bracket, only available with diameter 150 mm

4. Accuracy

- 4** ±1.5 % of full scale

5. Process connection

- D** 3/8"
E 1/2", only lower back mounting type

6. Connection type

- B** PF
C PT
D NPT
Z Other

7. Unit

- H** bar
I MPa
J kPa

8. Range

XXX Refer to pressure unit and range table

9. Pressure connection material and dial color

- 3** 316SS and 2 colors
7 316SS and 3 colors

10. Option

- 0** None
1 Accessories

1	2	3	4	5	6	7	8	9	10
P531	4	A	4	D	D	H	XXX	3	0

Sample
ordering code

P53X : Type of mounting

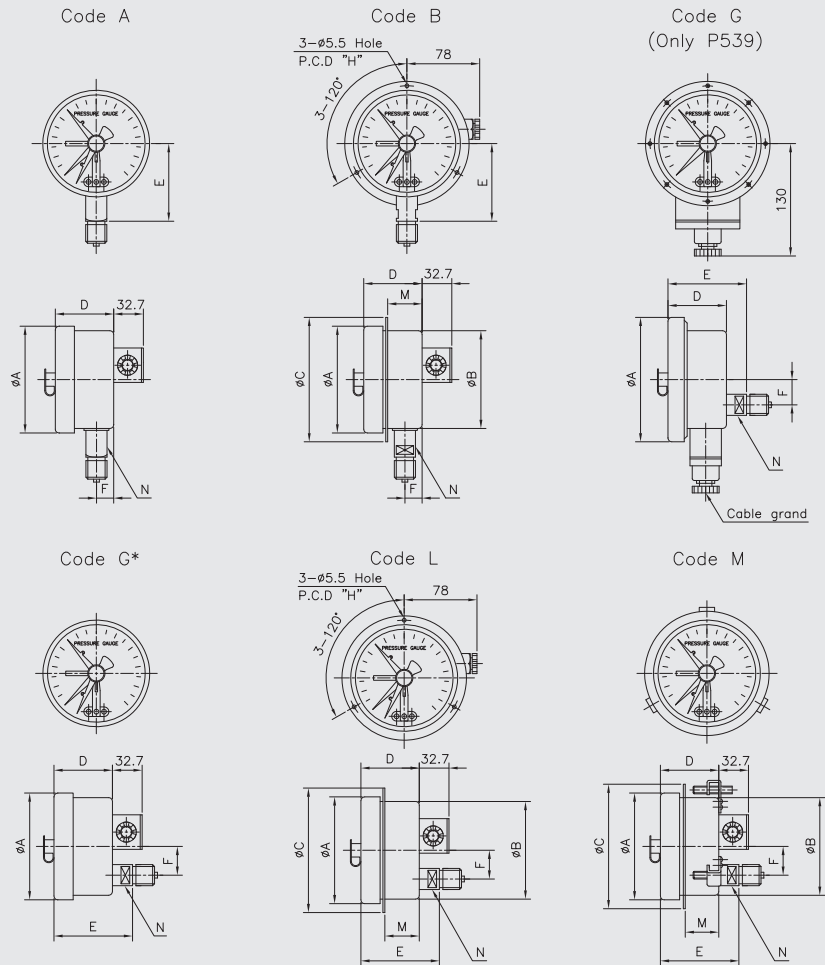

Dimensions (mm)

Dial size	Available code	A	B	C	D±2	E±2	F±1	H	M	N		
100	P531 P533	A	110			78.5	74	15		14		
		B	110	107	136	78.5	74	15	120	58.5	14	
		L	110	107	136	78.5	97.3	36	120	58.5	17	
	P532 P534	A	110			78.5	74	15			14	
		B	110	107	136	78.5	74	15	120	58.5	14	
		L	110	107	136	78.5	97.3	36	120	58.5	17	
	P537	A	110			78.5	74	15			14	
		B	110	107	136	78.5	74	15	120	58.5	14	
		L	110	107	136	78.5	97.3	36	120	58.5	17	
	P539	G	134			68	86	36			14	
	150	P531 P533	A	172			68.5	107	18.2			22
			G*	172			68.5	86.3	45			17
M			172	159	184	69	86.8	45		42	17	
P532 P534		A	172			68.5	107	18.2			22	
		G*	172			68.5	86.3	45			17	
		M	172	159	184	69	86.8	45		42	17	
P537		A	172			68.5	107	18.2			22	
		G*	172			68.5	86.3	45			17	
		M	172	159	184	69	86.8	45		42	17	

Snap - action contacts

General

Electromechanical limit switches in pointer type measuring instruments are auxiliary current switches which open or close electrical circuits at set limit values by means of a contact arm which is moved by the actual value pointer.

The snap action contact is a mechanical contact for switching capacities up to 30 W 50 VA max.

Contact making will be delayed and or advanced in relation to the movement of the actual value pointer.

To closed the circuit, the contact pin of the movable contact arm is attracted in a jump by the permanent magnet fastened to the supporting arm shortly before the set value has been reached.

Due to the retention force of the magnet, snap action contacts are more resistant against shock and vibration.

The switching safety is increased by the increased contact pressure.

When the circuit is opened, the magnet keeps the contact arm in its place until the restoring force of the measuring element exceeds the magnetic force, and the contact opens in a jump.

Specifications

Maximum contact rating with non-inductive (ohmic) load		Electrical contacts type pressure gauge model P530 series	
		Dry gauges	
Maximum voltage		250 V	
Current ratings	Make ratings	1.0 A	
	Break ratings	1.0 A	
	Continuos load	0.6 A	
Maximum load		30 W 50 VA	
Material of contact points		Silver-Nickel alloy (80 % Ag / 20 %Ni / 10 µm) gold-plated	
Ambient operating temperature		-20 °C...+70 °C	
Max. no. of contacts		2	
Voltage test		Circuit / protective earth conductor - 2,000 vac 1 minute	
		Circuit /circuit - 2,000 vac 1 minute	

Recommended contact ratings with ohmic and inductive load

Voltage (DIN IEC 38) DC / AC	Electrical contacts type pressure gauge model P530 series		
	Dry gauges		
	Ohmic load		Inductive load
	DC	AC	
			cosØ > 0.7
V	mA	mA	mA
220 / 230	100	120	65
110 / 110	200	240	130
48 / 48	300	450	200
24 / 24	400	600	250

In order to ensure a high switching reliability of the contacts the switching voltage should not be below 24 V, also taking environmental influences in the long term into account.

SPST switching element

Single-pole, single throw (SPST) has two connection : C-common, NO-normally open, which allows the switching element to be electrically to the circuit NO state.

One SPST

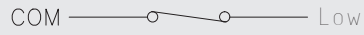
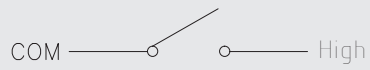

Two SPST

NO : Normal open
NC : Normal close

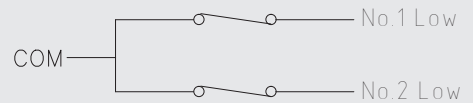
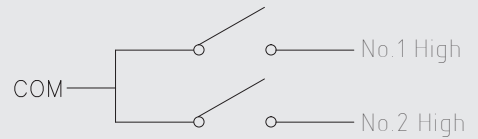
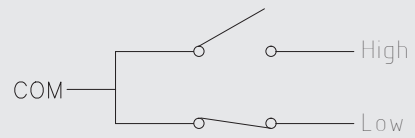

Pressure unit and range table

Range and code	Unit and code			P531, P532, P533, P534, P537		P539
	H : bar	I : MPa	J : kPa	100 mm	150 mm	100 mm
026	-1 ~ 0	-0.1 ~ 0	-100 ~ 0	O	O	O
040	0 ~ 0.5	0 ~ 0.05	0 ~ 50	O	X	O
041	0 ~ 1	0 ~ 0.1	0 ~ 100	O	O	O
042	0 ~ 2	0 ~ 0.2	0 ~ 200	O	O	O
043	0 ~ 3	0 ~ 0.3	0 ~ 300	O	O	O
044	0 ~ 4	0 ~ 0.4	0 ~ 400	O	O	O
045	0 ~ 6	0 ~ 0.6	0 ~ 600	O	O	O
047	0 ~ 10	0 ~ 1	0 ~ 1,000	O	O	O
050	0 ~ 15	0 ~ 1.5	X	O	O	O
051	0 ~ 20	0 ~ 2	X	O	O	O
052	0 ~ 25	0 ~ 2.5	X	O	O	O
054	0 ~ 35	0 ~ 3.5	X	O	O	O
055	0 ~ 50	0 ~ 5	X	O	O	O
057	0 ~ 70	0 ~ 7	X	O	O	O
058	0 ~ 100	0 ~ 10	X	O	O	O
059	0 ~ 150	0 ~ 15	X	O	O	O
062	0 ~ 250	0 ~ 25	X	O	O	O
064	0 ~ 350	0 ~ 35	X	O	O	O
066	0 ~ 500	0 ~ 50	X	O	O	O
068	0 ~ 700	0 ~ 70	X	O	O	O
070	0 ~ 1,000	0 ~ 100	X	O	O	O
027	-1 ~ 1	-0.1 ~ 0.1	-100 ~ 100	O	O	O
028	-1 ~ 2	-0.1 ~ 0.2	-100 ~ 200	O	O	O
029	-1 ~ 3	-0.1 ~ 0.3	-100 ~ 300	O	O	O
030	-1 ~ 4	-0.1 ~ 0.4	-100 ~ 400	O	O	O
031	-1 ~ 6	-0.1 ~ 0.6	-100 ~ 600	O	O	O
032	-1 ~ 10	-0.1 ~ 1	-100 ~ 1,000	O	O	O
033	-1 ~ 15	-0.1 ~ 1.5	-100 ~ 1.5 MPa	O	O	O
034	-1 ~ 20	-0.1 ~ 2	-100 ~ 2 MPa	O	O	O

O : Available X : Not available