

# Receiver gauge

## Model : P228 series

Spec. sheet no. PD02-03

### Service intended

P228 series are designed to meet the general requirements of a process industry, and it could provide a remote or a local indication.

EAC

### Nominal diameter

100 and 160 mm

### Accuracy

±1.0 % of full scale

### Scale range (MPa, kPa, bar)

0 ~ 10 % square root scale

0 ~ 100 % linear scale

### Working pressure

Steady : 75 % of full scale

Over range protection : 130 % of full scale

### Working temperature

Ambient : -40 ~ 65 °C

Fluid : Max. 200 °C

### Degree of protection

EN60529/IEC529/IP65

### Temperature effect

Accuracy at temperature above and below the reference temperature (20 °C) will be effected by approximately ±0.4 % per 10 °C of full scale



## Standard features

### Pressure connection

Stainless steel (316SS)

### Movement

Stainless steel

### Element

Stainless steel (316SS)

C type bourdon tube

### Dial

White aluminium with black graduations

### Case

Stainless steel (304SS)

### Pointer

Black painted aluminium alloy

### Cover

Stainless steel (304SS)

### Process connection

¼", ⅜", ½" PT, NPT and PF

¼" PT(F), ¼" NPT(F)

### Window

Safety glass

### Process input

0.02 ~ 0.1 MPa

**WISE**<sup>®</sup>

I P228\_01

**1. Base model**

**P228** Receiver gauge

**2. Nominal diameter (mm)**

**4** 100  
**6** 160

**3. Type of mounting**

**A** Bottom connection, direct  
**B** Bottom connection, surface, case mounting plate  
**G** Lower back connection, direct  
**L** Lower back connection, surface, case mounting plate  
**M** Lower back connection, flush, case center mounting bracket  
**N** Lower back connection, flush, cover mounting plate  
**W** Lower back connection, flush, cover mounting bracket

**4. Accuracy**

**3** ±1.0 % of full scale

**5. Process connection**

**C** 1/4"  
**D** 3/8"  
**E** 1/2"

**6. Connection type**

**B** PF  
**C** PT  
**D** NPT  
**Z** PT(F)  
**Y** NPT(F), only available with connection 1/4"

**7. Process input**

**X** 0.02 ~ 0.1MPa  
**W** 0.2 ~ 1 kgf/cm<sup>2</sup>  
**Y** 3 ~ 15 psi

**8. Range**

**398** 0 ~10, square root scale  
**399** 0 ~100, linear scale

**9. Dial color**

**3** 2 colors  
**7** 3 colors

**10. Option**

**0** None  
**1** Accessories

1	2	3	4	5	6	7	8	9	10
P228	4	A	3	E	D	W	398	3	0

Sample  
ordering code

## P228 : Type of mounting

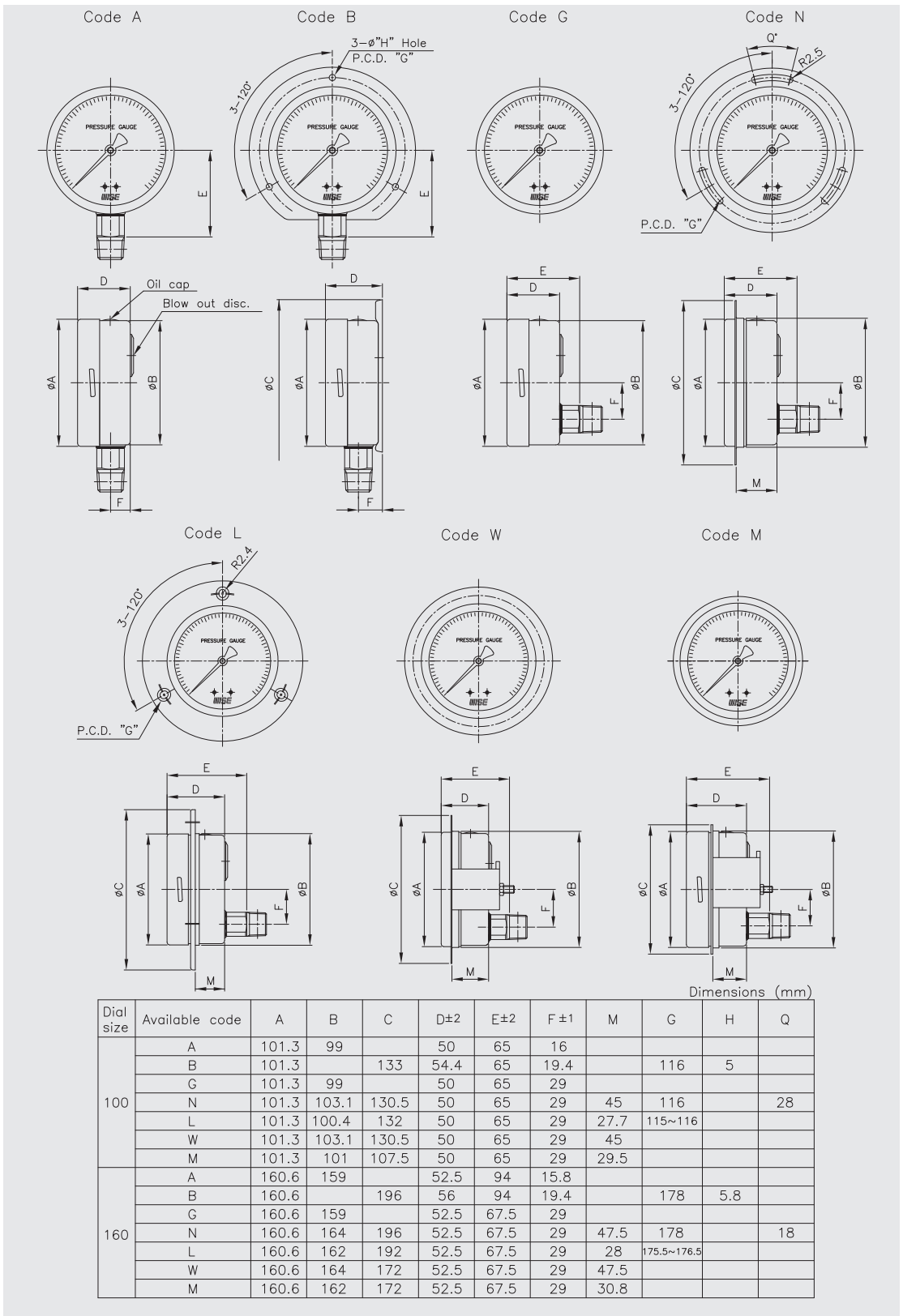

## Conversion table

Pressure conversion chart

psi	atm	kgf/cm <sup>2</sup>	inH <sub>2</sub> O	mmHg	inHg	kPa	bar	mmH <sub>2</sub> O
1	0.068046	0.070307	27.7276	51.715	2.03602	6.835	0.06895	704.28104
14.696	1	1.0332	407.484	760	29.921	101.325	1.01325	10,350.0936
14.2233	0.96784	1	394.38	735.559	28.959	98.096	0.98067	10,000
0.036092	0.002454	0.00253	1	1.8651	0.07343	0.249	0.00249	25.4
0.019336	0.001315	0.001359	0.53616	1	0.03937	0.1333	0.001333	13.618464
0.491154	0.0033421	0.03453	13.6185	25.4	1	3.3864	0.033864	345.9099
0.145	0.00987	0.010197	4.0186	7.5006	0.2953	1	0.01	102.07244
14.5038	0.98692	1.01972	402.156	750.062	29.53	100	1	10,214.7624
0.00142	0.000097	0.0001	0.03937	0.0734	0.0029	0.0098	0.000098	1

## Memo