

Ammonia service pressure gauge

Model : P111 series

Spec. sheet no. PD0-02

Service intended

P111 series are designed to withstand the shock, the vibration, and the pulsation which could be generated from the agricultural ammonia equipment.



Nominal diameter

60, 75 and 100 mm

Accuracy

±1.5 % of full scale

Scale range (MPa, kPa, bar)

-0.1 ~ 1, 1.5, 2 MPa

Working pressure

Steady : 75 % of full scale

Over range protection : 130 % of full scale

Working temperature

Ambient : -40 ~ 65 °C

Fluid : Max. 200 °C

Temperature effect

Accuracy at temperature above and below the reference temperature (20 °C) will be effected by approximately ±0.4 % per 10 °C of full scale



Standard features

Pressure connection

316SS

Movement

Brass

Element

316SS

C type bourdon tube

Dial

White aluminium with black graduations

Case

Black finished steel

Pointer

Black painted aluminium alloy

Cover

Black finished steel

Window

Glass

Process connection

1/4" PT, 3/8" PT and PF

WISE[®]

| P111_01

1. Base model

P111 Ammonia service pressure gauge

2. Nominal diameter (mm)

- 2 60
- 3 75
- 4 100

3. Type of mounting

- A** Bottom connection, direct
- B** Bottom connection, surface, case mounting plate
- M** Lower back connection, flush, case center mounting bracket, only available with diameter 100 mm

4. Accuracy

- 4 ±1.5 % of full scale

5. Process connection

- C** ¼"
- D** ⅜"

6. Connection type

- B** PF
- C** PT

7. Unit

- H** bar
- I** MPa
- J** kPa

8. Range

- 032** -0.1 ~ 1 MPa (-1 ~ 10 bar)
- 033** -0.1 ~ 1.5 MPa (-1 ~ 15 bar)
- 034** -0.1 ~ 2.0 MPa (-1 ~ 20 bar)

9. Dial color

- 6 3 colors

10. Option

- 0 None
- 1 Accessories

1	2	3	4	5	6	7	8	9	10
P111	2	A	4	C	C	H	033	6	0

Sample
ordering code

P111 : Type of mounting

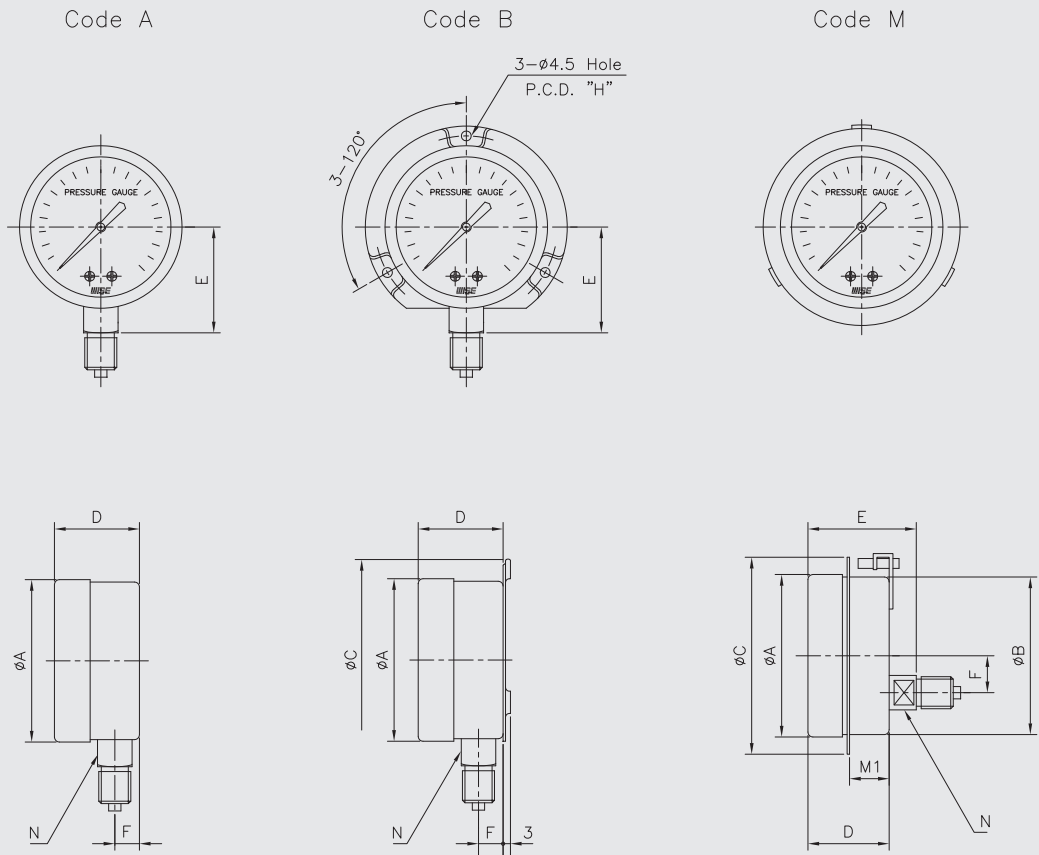

Dimensions (mm)

Dial size	Available code	A	B	C	D ± 2	E ± 2	F ± 1	H	M1	N
60	A,B	66		82	31.5	42	11	74		14
75	A,B	78		100	34.7	52	12.7	90		17
100	A,B	106		128	35	64.5	12.7	115		17
	M	103.5	102	128	40.5	61.5	36		14	17