

# Industrial service pressure gauge (125 mm)

## Model : P222 series

Spec. sheet no. PD02-02

### Service intended

P222 are suitable to be used in a corrosive environment, chemical, petro-chemical, refining facilities, power generation, marine and foods industry. Its stainless steel case and cover have a good appearance and an excellent protection against corrosion and chemical attack.

EAC

### Nominal diameter

125 mm (4½")

### Accuracy

±0.5 % of full scale

±1.0 % of full scale

### Scale range (MPa, kPa, bar)

-0.1 ~ 0 to 0 ~ 200 MPa

### Working pressure

Steady : 75 % of full scale

Over range protection : 130 % of full scale

### Working temperature

Ambient : -40 ~ 65 °C

-20 ~ 65 °C (With glycerin filling)

-40 ~ 65 °C (With silicone filling)

Fluid : Max. 200 °C

Max. 100 °C (With glycerin filling)

Max. 100 °C (With silicone filling)

### Degree of protection

EN60529/IEC529/IP67

### Temperature effect

Accuracy at temperature above and below the reference temperature (20 °C) will be effected by approximately ±0.4 % per 10 °C of full scale



## Standard features

### Pressure connection

Stainless steel (316SS)

### Element

316SS

< 10 MPa : C type bourdon tube

≥ 10 MPa : Helical type bourdon tube

### Case

Stainless steel (304SS)

### Cover

Stainless steel (304SS)

Bayonet type

### Window

Safety glass

### Blowout protection

Back, rubber disc

### Movement

Stainless steel

### Dial

White aluminium with black graduations

### Pointer

Black painted aluminium alloy

### Process connection

⅜", ½" PT, NPT and PF

### Zero adjustment

Internal : Micro zero adjustable pointer

**WISE**<sup>®</sup>

I P222\_01

**1. Base model**

**P222** Industrial service pressure gauge

**2. Nominal diameter**

**5** 125 mm (4½")

**3. Type of mounting**

**A** Bottom connection, direct

**4. Accuracy**

**2** ±0.5 % of full scale

**3** ±1.0 % of full scale

**5. Process connection**

**D** ⅜"

**E** ½"

**6. Connection type**

**B** PF

**C** PT

**D** NPT

**F** BSPT

**G** BSP

**Z** Other

**7. Unit**

**H** bar

**I** MPa

**J** kPa

**8. Range**

**XXX** Refer to pressure unit and range table

**9. Dial color**

**3** 2 colors

**7** 3 colors

**10. Option**

**0** None

**1** Accessories

**2** Glycerin filling

**3** Silicone filling

**4** Accessories and glycerin filling

**5** Accessories and silicone filling

1	2	3	4	5	6	7	8	9	10
<b>P222</b>	<b>5</b>	<b>A</b>	<b>3</b>	<b>E</b>	<b>D</b>	<b>H</b>	<b>XXX</b>	<b>3</b>	<b>2</b>

Sample  
ordering code

P222 : Type of mounting

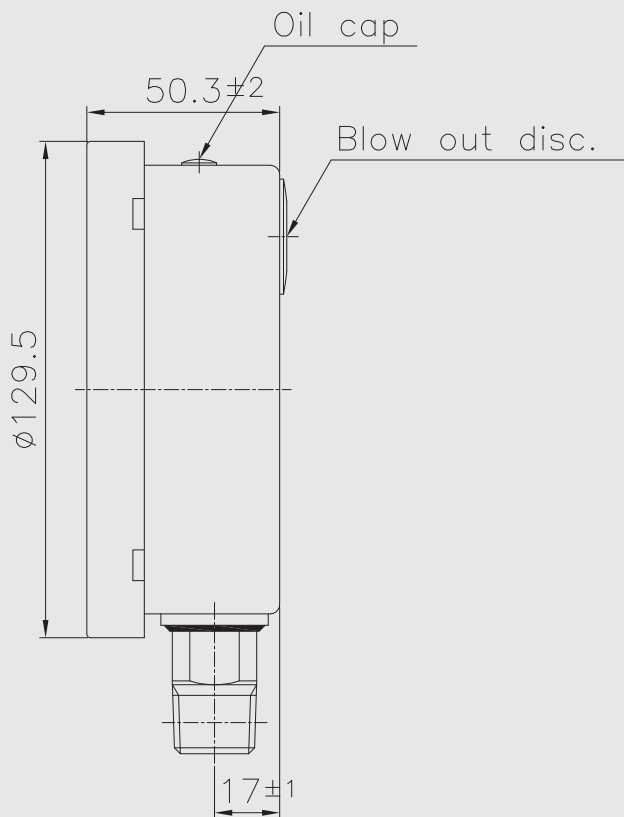
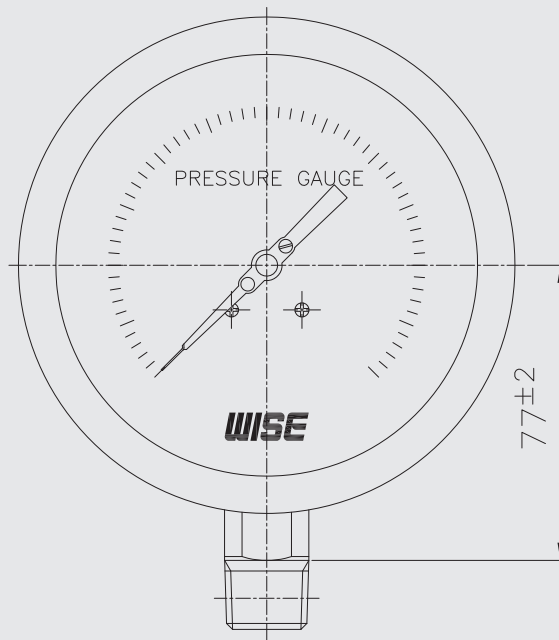

## Pressure unit and range table

Range and code	Unit and code			Nominal diameter
	H : bar	I : MPa	J : kPa	125 mm (4½")
026	-1 ~ 0	-0.1 ~ 0	-100 ~ 0	O
040	0 ~ 0.5	0 ~ 0.05	0 ~ 50	O
041	0 ~ 1	0 ~ 0.1	0 ~ 100	O
133	0 ~ 1.6	0 ~ 0.16	0 ~ 160	O
042	0 ~ 2	0 ~ 0.2	0 ~ 200	O
134	0 ~ 2.5	0 ~ 0.25	0 ~ 250	O
043	0 ~ 3	0 ~ 0.3	0 ~ 300	O
044	0 ~ 4	0 ~ 0.4	0 ~ 400	O
045	0 ~ 6	0 ~ 0.6	0 ~ 600	O
047	0 ~ 10	0 ~ 1	0 ~ 1,000	O
050	0 ~ 15	0 ~ 1.5	X	O
143	0 ~ 16	0 ~ 1.6	X	O
051	0 ~ 20	0 ~ 2	X	O
052	0 ~ 25	0 ~ 2.5	X	O
054	0 ~ 35	0 ~ 3.5	X	O
151	0 ~ 40	0 ~ 4	X	O
055	0 ~ 50	0 ~ 5	X	O
056	0 ~ 60	0 ~ 6	X	O
057	0 ~ 70	0 ~ 7	X	O
058	0 ~ 100	0 ~ 10	X	O
059	0 ~ 150	0 ~ 15	X	O
060	0 ~ 160	0 ~ 16	X	O
062	0 ~ 250	0 ~ 25	X	O
064	0 ~ 350	0 ~ 35	X	O
065	0 ~ 400	0 ~ 40	X	O
066	0 ~ 500	0 ~ 50	X	O
067	0 ~ 600	0 ~ 60	X	O
068	0 ~ 700	0 ~ 70	X	O
070	0 ~ 1,000	0 ~ 100	X	O
074	0 ~ 1,600	0 ~ 160	X	O
075	0 ~ 2,000	0 ~ 200	X	O
027	-1 ~ 1	-0.1 ~ 0.1	-100 ~ 100	O
007	-1 ~ 1.5	-1 ~ 0.15	-100 ~ 150	O
028	-1 ~ 2	-0.1 ~ 0.2	-100 ~ 200	O
029	-1 ~ 3	-0.1 ~ 0.3	-100 ~ 300	O
030	-1 ~ 4	-0.1 ~ 0.4	-100 ~ 400	O
010	-1 ~ 5	-0.1 ~ 0.5	-100 ~ 500	O
031	-1 ~ 6	-0.1 ~ 0.6	-100 ~ 600	O
014	-1 ~ 9	-0.1 ~ 0.9	-100 ~ 900	O
032	-1 ~ 10	-0.1 ~ 1	-100 ~ 1,000	O
033	-1 ~ 15	-0.1 ~ 1.5	-100 ~ 1.5 MPa	O
034	-1 ~ 20	-0.1 ~ 2	-100 ~ 2 MPa	O
017	-1 ~ 24	-0.1 ~ 2.4	-100 ~ 2.4 MPa	O
035	-1 ~ 25	-0.1 ~ 2.5	-100 ~ 2.5 MPa	O

O : Available X : Not available