

# Liquid filled remote reading thermometer

**Model : T219**

Spec. sheet no. TD02-04

## Service intended

Liquid filled thermometer is used for measuring temperature of corrosive and non-corrosive fluid in all industries. It operates in aggressive and non-aggressive environment. Linear dials and temperature compensate line assure an accurate temperature indication at varying ambient conditions.



## Nominal diameter

100 and 150 mm

## Accuracy

±2.0 % of full scale

## Measuring system (SAMA class IIIB)

Organic gas : 0 ~ 200 °C

Inert gas : -200 ~ 700 °C

## Working range

Maximum scale value



## Standard features

### Location of stem and mounting

Bottom connection, surface, case mounting  
lower back connection, flush,  
case center mounting bracket

### Case

304SS

### Cover

304SS

### Capillary

Capillary : 1.6/0.2 mm, 316SS

Armored tube : 7.5/5.5 mm, 304SS

### Window

Tempered safety glass

### Dial

White aluminium with black graduation

### Pointer

304SS, Black painted

### Stem

8.0, 10.0 and 12.0 mm

316SS and 316L SS

### Filling liquid

Glycerin or silicone

### Stem, process connection

3/8", 1/2", 3/4" PT, NPT and PF

### Option

±1.0 % of full scale

**WISE®**

I T219\_01

**1. Base model****T219** Liquid filled remote reading thermometer**2. Nominal diameter (mm)**

**4** 100  
**6** 150

**3. Type of mounting**

**B** Bottom connection, surface, case mounting plate  
**M** Lower back connection, flush, case center mounting bracket

**4. Stem material**

**1** 316SS  
**2** 316L SS

**5. Stem, process connection**

**A** None  
**D** 3/8"  
**E** 1/2"  
**F** 3/4"

**6. Stem connection type (CF: Compression fitting)**

**A** None  
**E** CF + PT  
**F** CF + NPT  
**G** CF + PF  
**H** MT + PT (Movable thread)  
**I** MT + NPT (Movable thread)  
**J** MT + PF (Movable thread)

**7. Stem outer diameter (mm)**

**2** 8.0  
**3** 10.0  
**4** 12.0  
**Z** Other

**8. Range****XXX** Refer to scale range table**9. Capillary length (m)**

**P** 2  
**Q** 3  
**S** 5  
**V** 8  
**X** 10  
**Z** Other

**10. Accessories**

**0** None  
**1** Thermowell  
**2** Special accuracy ( $\pm 1.0\%$  of full scale)  
**3** Thermowell and special accuracy

|             |          |          |          |          |          |          |            |          |          |
|-------------|----------|----------|----------|----------|----------|----------|------------|----------|----------|
| 1           | 2        | 3        | 4        | 5        | 6        | 7        | 8          | 9        | 10       |
| <b>T219</b> | <b>4</b> | <b>B</b> | <b>1</b> | <b>E</b> | <b>C</b> | <b>3</b> | <b>XXX</b> | <b>P</b> | <b>1</b> |

Sample  
ordering code

## T219 : Type of mounting

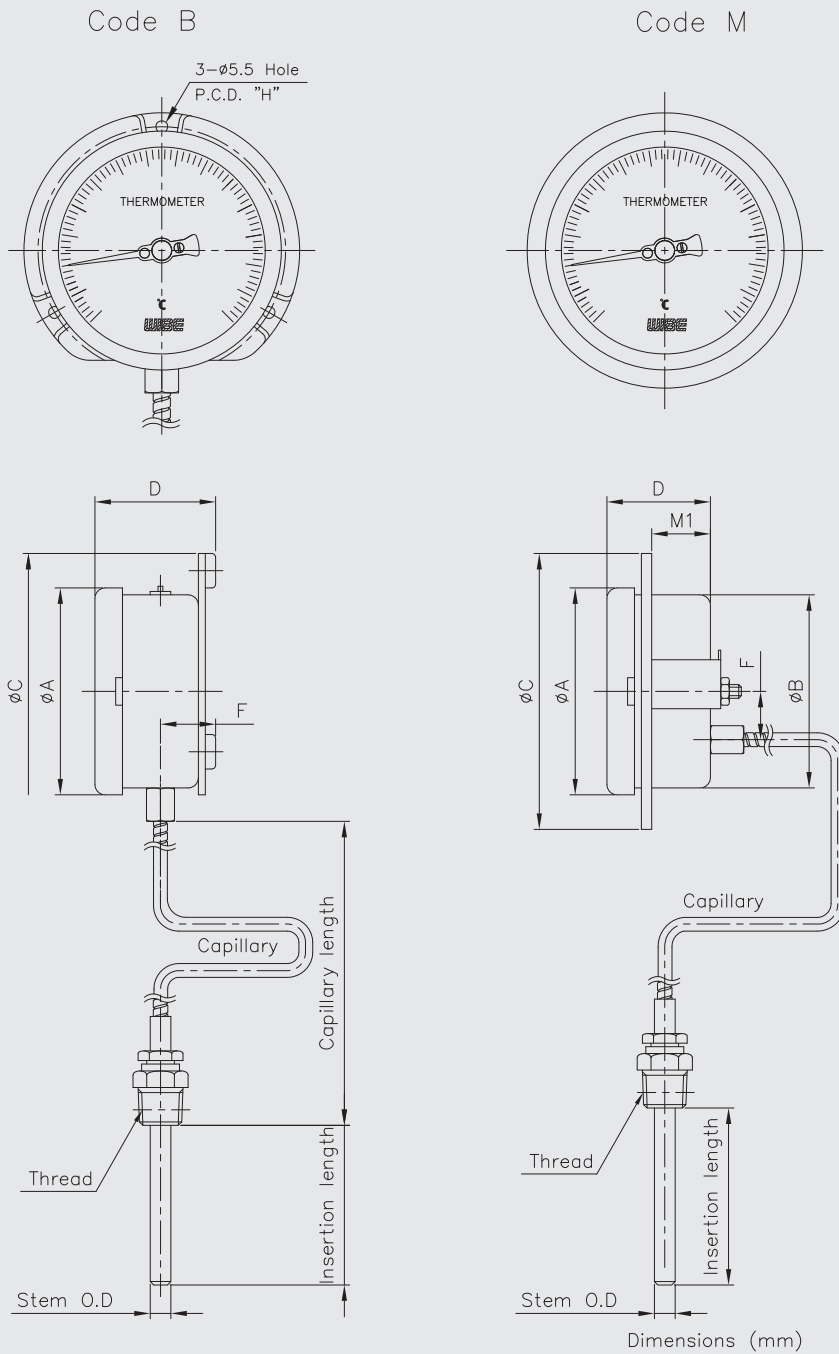

| Dial Size | Available code | A     | B    | C   | D $\pm$ 2 | F $\pm$ 1 | H   | M1   |
|-----------|----------------|-------|------|-----|-----------|-----------|-----|------|
| 100       | B              | 111   |      | 128 | 53.5      | 18        | 115 |      |
|           | M              | 111   | 99.5 | 128 | 50.5      | 30        |     | 28.5 |
| 150       | B              | 169.5 |      | 178 | 66.5      | 25.5      | 165 |      |
|           | M              | 169.5 | 153  | 178 | 63        | 55        |     | 38.5 |

## Scale ranges

| Code | Scale range (°C) | Scale spacing(°C) | Minimum stem length (mm) |      |      | Standard stem length (mm) |      |      |
|------|------------------|-------------------|--------------------------|------|------|---------------------------|------|------|
|      |                  |                   | 8.0                      | 10.0 | 12.0 | 8.0                       | 10.0 | 12.0 |
| 031  | -200 ~ 100       | 5                 | 100                      | 85   | 65   | 200                       | 130  | 100  |
| 032  | -50 ~ 50         | 2                 | 100                      | 85   | 65   | 200                       | 130  | 100  |
| 037  | -50 ~ 100        | 2                 | 100                      | 88   | 65   | 200                       | 130  | 100  |
| 054  | -30 ~ 50         | 2                 | 100                      | 85   | 65   | 200                       | 130  | 100  |
| 059  | -30 ~ 100        | 2                 | 100                      | 85   | 65   | 200                       | 130  | 100  |
| 061  | -30 ~ 120        | 2                 | 100                      | 85   | 65   | 200                       | 130  | 100  |
| 069  | -20 ~ 50         | 2                 | 100                      | 85   | 65   | 200                       | 130  | 100  |
| 074  | -20 ~ 100        | 2                 | 100                      | 85   | 65   | 200                       | 130  | 100  |
| 079  | -20 ~ 150        | 5                 | 100                      | 85   | 65   | 200                       | 130  | 100  |
| 084  | -10 ~ 50         | 1                 | 100                      | 85   | 65   | 200                       | 130  | 100  |
| 099  | 0 ~ 50           | 1                 | 100                      | 85   | 65   | 200                       | 130  | 100  |
| 100  | 0 ~ 60           | 1                 | 100                      | 85   | 65   | 200                       | 130  | 100  |
| 101  | 0 ~ 70           | 2                 | 100                      | 85   | 65   | 200                       | 130  | 100  |
| 102  | 0 ~ 80           | 2                 | 100                      | 85   | 65   | 200                       | 130  | 100  |
| 104  | 0 ~ 100          | 2                 | 100                      | 85   | 65   | 200                       | 130  | 100  |
| 106  | 0 ~ 120          | 2                 | 100                      | 85   | 65   | 200                       | 130  | 100  |
| 109  | 0 ~ 150          | 2                 | 100                      | 85   | 65   | 200                       | 130  | 100  |
| 114  | 0 ~ 200          | 5                 | 100                      | 85   | 65   | 200                       | 130  | 100  |
| 119  | 0 ~ 250          | 5                 | 100                      | 85   | 65   | 200                       | 130  | 100  |
| 124  | 0 ~ 300          | 5                 | 100                      | 85   | 65   | 200                       | 130  | 100  |
| 129  | 0 ~ 350          | 5                 | 100                      | 85   | 65   | 200                       | 130  | 100  |
| 134  | 0 ~ 400          | 10                | 100                      | 85   | 65   | 200                       | 130  | 100  |
| 144  | 0 ~ 500          | 10                | 100                      | 85   | 65   | 200                       | 130  | 100  |
| 154  | 0 ~ 600          | 10                | 100                      | 85   | 65   | 200                       | 130  | 100  |
| 164  | 0 ~ 700          | 10                | 100                      | 85   | 65   | 200                       | 130  | 100  |

\* 0 ~ 700 °C/Special range

\* -200 ~ 100 °C/Special range

## Insertion length

| Code        | 1  | 2  | 3  | 4  | 5   | 6   | 7   | 8   | 9   | A   | B   | C   |
|-------------|----|----|----|----|-----|-----|-----|-----|-----|-----|-----|-----|
| Length (mm) | 50 | 60 | 70 | 80 | 100 | 120 | 130 | 150 | 175 | 200 | 225 | 250 |

| Code        | D   | E   | F   | G   | H   | J   | K   | L   | M     | N     | P     |
|-------------|-----|-----|-----|-----|-----|-----|-----|-----|-------|-------|-------|
| Length (mm) | 275 | 300 | 350 | 375 | 400 | 450 | 500 | 550 | 1,000 | 1,500 | 2,000 |