



OPTISONIC 3400 Technical Datasheet

- Measurement of (non-) conductive, low and high viscous liquids, from -200°C to +250°C media temperature
- Accurate bi-directional measurement that starts from zero flow
- Advanced signal converter, covering all I/O 's and communication protocols



1	Product features	4
1.1	Multipurpose, all round ultrasonic flow meter in all process industries	4
1.2	Variants	6
1.3	Features	7
1.4	Measuring principle	8
2	Technical data	9
2.1	Technical data	9
2.2	Dimensions and weights	21
2.2.1	Variants	21
2.2.2	Standard flow sensor	22
2.2.3	Variant flow sensor; XXT - High Viscosity and Cryogenic (SS) versions	28
2.2.4	Signal converter housing	34
3	Installation	35
3.1	Intended use	35
3.2	General notes on installation	35
3.3	Vibration	35
3.4	Installation requirements signal converter	36
3.5	Installation conditions	36
3.5.1	Inlet and outlet	36
3.5.2	Bends in 2 or 3 dimensions	36
3.5.3	T-section	37
3.5.4	Bends	37
3.5.5	Open feed or discharge	38
3.5.6	Position of pump	38
3.5.7	Control valve	38
3.5.8	Down going pipeline over 5 m /16 ft length	39
3.5.9	Insulation	39
3.5.10	Mounting	40
3.5.11	Flange deviation	40
3.5.12	Mounting position	40
4	Electrical connections	41
4.1	Safety instructions	41
4.2	Signal cable (remote versions only)	41
4.3	Power supply	42
4.4	Inputs and outputs, overview	43
4.4.1	Combinations of the inputs/outputs (I/Os)	43
4.4.2	Description of the CG number	44
4.4.3	Fixed, non-alterable input/output versions	45
4.4.4	Alterable input/output versions	46
5	Applications	47

5.1 Device Configuration Form	47
6 Notes	49

1.1 Multipurpose, all round ultrasonic flow meter in all process industries

The **OPTISONIC 3400** flowmeter is an unique, 3-beam, inline, ultrasonic flowmeter, designed especially for measuring homogeneous conductive and non-conductive liquids, with high accuracy and reproducibility, over a long period of time. KROHNE is a main supplier for ultrasonic in-line process flowmeters for liquids with the largest installed base / proven record in terms of robustness and measurement accuracy.

Building on vast knowledge and expertise, KROHNE now introduces the **OPTISONIC 3400**. This flowmeter is able to measure:

- conductive and non-conductive liquids
- cryogenic - and high process temperatures
- standard and straightforward applications and applications that require high performance
- non-viscous aqueous liquids and extreme viscous liquids
- low pressure ratings and extreme pressure ratings



- ① High performance signal converter for all applications
- ② Robust body without moving parts

The **OPTISONIC 3400** ...features advanced meter diagnostics.

This provides extensive self-checking of internal circuits and information regarding the health of the measuring sensor, but just as importantly, vital information about the process and process conditions.

Fieldbuses are, HART[®]7, Foundation Fieldbus, Profibus PA/DP and Modbus, all with NAMUR NE 107. These advanced diagnostic features makes process life comfortable, reliable and accurate over a long period of time.

The **OPTISONIC 3400** ...features velocity of sound

Another unique feature of the **OPTISONIC 3400** is the free of charge measurement of velocity of sound per acoustic path. For instance, this can supply information about pollution in the liquid, or changes in the process conditions.

Highlights

- Advanced signal converter with full range of I/O 's and communication protocols
- Diagnostic functions according to NAMUR NE107
- Improved user interface: optical- and push buttons
- Completely welded construction, wear and maintenance free
- Full bore, unobstructed sensor tube, without pressure loss and without moving parts
- Accurate bi-directional flow measurement, with three beams to measure continuously, and starts measurement at nearly zero flow
- Multipurpose, all round, ultrasonic flowmeter for single phase liquids

Industries

- Chemicals
- Petrochemicals
- Oil & Gas
- Energy
- Water (utilities)

Applications

- Conductive and non-conductive liquids
- Cryogenic- and high process temperature, low and extreme high pressure range
- Expanded applicability; for standard and high performance applications
- Measuring aqueous liquids as well as extreme viscous oils
- High turn down ratio; e.g. transportation pipeline measurements
- Broad pressure and temperature range (e.g. midstream oil measurements)
- Multiple products; e.g. allocation measurements in on/off loading
- Water utilities in all process industries; make-up water, boiler feed water, demineralized water

1.2 Variants

An **OPTISONIC 3400** flowmeter consists of an OPTISONIC 3000 flow sensor and an UFC 400 signal converter. The standard version is available as a compact and remote version. Next to standard, also variants for demanding applications can be supplied.

OPTISONIC 3000

Flow sensor variants for demanding applications

A full range of flow sensors to cover simple to difficult applications, such as:

- For extended process temperatures up to 250°C / 482°F (remote version)
- Cryogenic version: for extreme low process temperatures, as low as -200°C / [-328°F (remote version, IP68)
- Flow sensor $\geq 14"$ and UFC 400 remote converter (aluminium or stainless steel housing)
- High viscous liquids: range from 100...1000 cSt



Variants available on request



Including heating jacket

- for steam or thermal oil tracing of the flowmeter
- suitable for standard and variant for extended process temperatures (remote)



Flangeless, weld-in connections

- greenfield
- flexibility in inner pipe diameters

1.3 Features

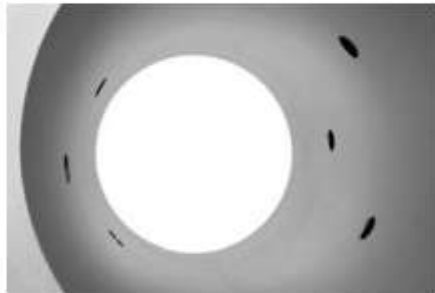

Engineers favorite flow meter

- All welded sensor construction
- Patented inert metal transducer technology
- No moving parts
- Full bore unobstructed sensor
- No need for auxiliary parts



UFC 400 signal converter - Compact and Remote/field

- Display with 4 optical -or push buttons
- Many I/O configurations available
- Fieldbuses HART®7 (and HART registration)
- Optional Foundation Fieldbus, ITK6, Modbus /RS485, Profibus PA/DP
- (all included with NAMUR NE107 diagnostics)
- One universal software for all applications



Failure
Output signal invalid



Check function
Output signal (temporarily) invalid



Out of specification
Unreliability of output signal



Maintenance required
Output signal still valid

UFC 400 diagnostic capabilities: NE107

- NE107 icons for status messages and error handling
- visible on UFC 400 display
 - via all communication protocols
 - Status messages are grouped by problem source
 - User can change group or priority

1.4 Measuring principle

- Like canoes crossing a river, acoustic signals are transmitted and received along a diagonal measuring path.
- A sound wave going downstream with the flow travels faster than a sound wave going upstream against the flow.
- The difference in transit time is directly proportional to the mean flow velocity of the medium.

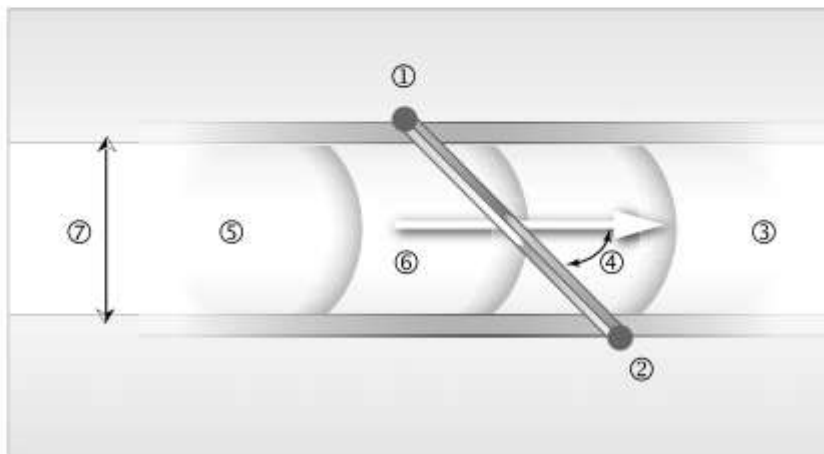

Figure 1-1: Measuring principle

- ① Transducer A
- ② Transducer B
- ③ Flow velocity
- ④ Angle of incidence
- ⑤ Velocity of sound of liquid
- ⑥ Path length
- ⑦ Inner diameter

2.1 Technical data

- *The following data is provided for general applications. If you require data that is more relevant to your specific application, please contact us or your local sales office.*
- *Additional information (certificates, special tools, software,...) and complete product documentation can be downloaded free of charge from the website (Download Center).*

Measuring system

Measuring principle	Ultrasonic transit time
Application range	Flow measurement of (non) conductive fluids
Measured value	
Primary measured value	Transit time
Secondary measured values	Volume flow, mass flow, flow speed, flow direction, velocity of sound, gain, signal to noise ratio, reliability of flow measurement, totalised volume or mass

Design

Features	3 parallel acoustic paths fully welded.
Modular construction	The measurement system consists of a measuring sensor and a signal converter.
Compact version	OPTISONIC 3400
Remote version	OPTISONIC 3000 F with UFC 400 signal converter
Nominal diameter	DN25...3000 / 1...120"
Measurement range	0.3...20 m/s / 0.98...65 ft/s
Signal converter	
Inputs / outputs	Current (incl. HART®), pulse, frequency and/or status output, limit switch and/or control input (depending on the I/O version)
Totaliser	2 (optional 3) internal totalisers with a max. of 8 digits (e.g. for totalising volume and/or mass units)
Verification and self-diagnostics	Integrated verification, diagnostic functions: measuring device, process, measured values, device configuration, etc.
Communication interfaces	Modbus RS485, HART® 7, Foundation Fieldbus ITK6, Profibus PA/DP Profile 3.02

Display and user interface	
Graphic display	LC display, backlit white
	Size: 128x64 pixels. Corresponds to 59x31 mm = 2.32"x1.22"
	Display turnable in 90° steps.
Operating elements	4 optical and push buttons for operator control of the signal converter without opening the housing.
	Option: Infrared interface [GDC]
Remote operation	PACTware™ including Device Type Manager [DTM]
	HART® handheld communicator (Emerson), AMS (Emerson), PDM (Siemens)
	All DTM's and drivers will be available at the internet homepage of the manufacturer.
Display functions	
Operating menu	Programming of parameters at 2 measured value pages, 1 status page, 1 graphic page (measured values and descriptions adjustable as required)
Language of display texts (as language package)	Standard: English, French, German, Dutch
	Russia: English, German, Russian
Measurement functions	Units: Metric, British and US units selectable as desired from lists for volume/mass flow and counting, velocity, temperature.
	Measured values: volume flow, mass flow, flow speed, velocity of sound, gain, signal to noise ratio, flow direction, diagnostics
Diagnostic functions	Standards: VDI/NAMUR NE 107
	Status messages: Output of status messages via display, current and/or status output, HART® or via other bus interface
	Sensor diagnostics: per acoustic path velocity of sound, flow speed, gain, signal to noise ratio
	Process diagnostics: empty pipe, signal integrity, cabling, flow conditions
	Signal converter diagnostics: data bus monitoring, I/O connections, electronics temperature, parameter and data integrity

Measuring accuracy

Reference conditions	
Medium	Water
Temperature	20°C / 68°F
Pressure	1 bar / 14.5 psi
Inlet section	10 DN
Maximum measuring error	
Standard:	±0.3% +2 mm/s of actual measured flow rate
Repeatability	±0.2%

Operating conditions

Temperature	
Process temperature	Compact version: -45...+140°C / -49...+284°F (for stainless steel housing at ambient temperature ≤ 45°C / +113°F)
	Remote version: -45...+180°C / -49...+356°F
	Extended temperature version: -45...+250°C / -49...+482°F (only remote version)
	Cryogenic version: -200...+180°C / -328...+356°F (only remote version, IP68, complete stainless steel)
	Carbon steel flanges; minimal process temperatures acc. to EN1092: -10°C / +14°F; ASME: -29°C / -20°F
Ambient temperature	Depending on the version and combination of outputs
	-40...+65°C / -40...+149°F
	Option (stainless steel converter housing): -40...+60°C / -40...+140°F
	Ambient temperatures below -25°C / -13°F may affect the readability of the display.
Protect inside electronics against self-heating (increasing of the electronics temperature will lead to a reduction of the corresponding service life by a factor 2 for each step of 10°C / 50°F increase). Protect the signal converter from external heat sources such as direct sunlight, as higher temperatures reduce the life cycle of all electronic components.	
Storage temperature	-50...+70°C / -58...+158°F
Pressure	
Atmospheric	
EN 1092-1	DN25...80: PN 40
	DN100...150: PN 16
	DN200...1000: PN 10
	DN1200...3000: PN 6
	Higher pressure ratings on request
ASME B16.5	1...24": 150 lb RF
	1...24": 300 lb RF
	1...24": 600 lb RF
	1...24": 900 lb RF
	Larger diameters on request.
JIS	DN25...40: 20K
	DN50...300: 10K
Properties of medium	
Physical condition	Liquid, single phase (well mixed, rather clean)
Permissible gas content	≤ 2% (volume)
Permissible solid content	≤ 5% (volume)
Viscosity	Standard: Up to 100 cSt (for all diameters)
	Option: High viscosity variant up to 1000 cSt

Installation conditions

Installation	For detailed information refer to <i>Installation</i> on page 35.
Inlet run	Minimal 5 DN (straight inlet)
	If no details are known, minimal 10 DN recommended
Outlet run	Minimal 3 DN (straight outlet)
	If no details are known, minimal 5 DN recommended
Dimensions and weights	For detailed information refer to <i>Dimensions and weights</i> on page 21.

Materials

Measuring sensor	
Flanges (wetted)	DN25...3000 / 1"..."120": Carbon steel
	Option: Stainless steel 1.4404 (AISI 316(L))
	Other materials on request.
Measuring Tube (wetted)	DN25...3000 / 1"..."120": Carbon steel
	Option: Stainless steel 1.4404 (AISI 316(L))
	Other materials on request.
Measuring sensor housing	DN25...300 / 1"..."12": Carbon steel
	Option: Stainless steel 1.4404 (AISI 316(L))
	For XXT, HV variant and DN25...3000 / 1"..."120": Carbon steel
	For Cryogenic variant and DN25...3000 / 1"..."120": Stainless steel 1.4404 (AISI 316(L))
Transducer	
Transducers (wetted)	Stainless steel 1.4404 (AISI 316L)
	Other materials on request.
Transducer holders incl. caps	DN350...3000 / 14"..."120"; Stainless steel 1.4404 (AISI 316L)
Tube transducer cabling	Stainless steel 1.4404 (AISI 316L)
Connection box and connection box support (remote version only)	Standard: Die-cast aluminium; polyurethane coated
	Option: Stainless steel 316 (1.4408)
Coating (measuring sensor)	Standard: Polyurethane
	Option: Offshore coating
NACE conformity	On request; wetted materials conform NACE MR 175/103
Signal converter	
Housing	Versions C and F: Die-cast aluminium
	Option: Stainless steel 316 (1.4408)
Coating	Standard: Polyurethane
	Option: Offshore coating

Electrical connections

Description of used abbreviations; $Q=xxx$; I_{max} = maximum current; $U_{i_n} = xxx$; U_{int} = internal voltage; U_{ext} = external voltage; $U_{int, max}$ = maximal internal voltage	
General	Electrical connection is carried out in conformity with the VDE 0100 directive "Regulations for electrical power installations with line voltages up to 1000 V" or equivalent national specifications.
Power supply	Standard: 100...230 VAC (-15% / +10%), 50/60 Hz
	Option: 24 VAC/DC (AC: -15% / +10%; DC: -25% / +30%)
Power consumption	AC: 22 VA
	DC: 12 W
Signal cable (remote version only)	MR06 (shielded cable with 6 coax cores): \varnothing 10.6 mm / 0.4"
	5 m / 16 ft
	Option: 10...30 m / 33...98 ft
Cable entries	Standard: M20 x 1.5 (8...12 mm)
	Option: 1/2" NPT, PF 1/2

Inputs and outputs

General	All outputs are electrically isolated from each other and from all other circuits.
	All operating data and output values can be adjusted.
Description of used abbreviations	U_{ext} = external voltage; R_L = load + resistance; U_0 = terminal voltage; I_{nom} = nominal current Safety limit values (Ex i): U_i = max. input voltage; I_i = max. input current; P_i = max. input power rating; C_i = max. input capacity; L_i = max. input inductivity

Current output			
Output data	Measurement of volume flow, mass flow, flow speed, velocity of sound, gain, SNR, diagnostics (flow speed, VoS, SNR, gain), NAMUR NE107, HART® communication.		
Temperature coefficient	Typically ± 30 ppm/K		
Settings	Without HART®		
	Q = 0%: 0...20 mA; Q = 100%: 10...20 mA		
	Error identification: 3...22 mA		
	With HART®		
	Q = 0%: 4...20 mA; Q = 100%: 10...20 mA		
	Error identification: 3...22 mA		
	Q = 100%: 10...20 mA		
Operating data	Basic I/Os	Modular I/Os	Ex i
	Active	$U_{\text{int, nom}} = 24$ VDC $I \leq 22$ mA $R_L \leq 1$ k Ω	$U_{\text{int, nom}} = 20$ VDC $I \leq 22$ mA $R_L \leq 450$ Ω $U_0 = 21$ V $I_0 = 90$ mA $P_0 = 0.5$ W $C_0 = 90$ nF / $L_0 = 2$ mH $C_0 = 110$ nF / $L_0 = 0.5$ mH
Passive	$U_{\text{ext}} \leq 32$ VDC $I \leq 22$ mA $U_0 \geq 1.8$ V $R_{L, \text{max}} = (U_{\text{ext}} - U_0) / I_{\text{max}}$	$U_{\text{ext}} \leq 32$ VDC $I \leq 22$ mA $U_0 \geq 4$ V $R_{L, \text{max}} = (U_{\text{ext}} - U_0) / I_{\text{max}}$ $U_i = 30$ V $I_i = 100$ mA $P_i = 1$ W $C_i = 10$ nF $L_i = 0$ mH	

HART®			
Description	HART® protocol via active and passive current output		
	HART® version: V7		
	Universal HART® parameter: completely integrated		
Load	≥ 250 Ω t HART® test point: Note maximum load for current output!		
Multidrop	Yes, current output = 10% e.g. 4 mA		
	Multidrop addresses adjustable in operation menu 0...63		
Device drivers	DD for FC 375/475, AMS, PDM, DTM for FDT		
Pulse or frequency output			
Output data	Volume flow, mass flow		
Function	Adjustable as pulse or frequency output		
Pulse rate/frequency	0.01...10000 pulses/s or Hz		
Settings	For Q = 100%: 0.01... 10000 pulses per second or pulses per unit volume.		
	Pulse width: adjustable as automatic, symmetric or fixed (0.05...2000 ms)		
Operating data	Basic I/Os	Modular I/Os	Ex i
Active	-	$U_{nom} = 24 \text{ VDC}$ f_{max} in operating menu set to: $f_{max} \leq 100 \text{ Hz}$: $I \leq 20 \text{ mA}$ $R_{L, max} = 47 \text{ k}\Omega$ open: $I \leq 0.05 \text{ mA}$ closed: $U_{0, nom} = 24 \text{ V}$ at $I = 20 \text{ mA}$	-
		F_{max} in operating menu set to: $100 \text{ Hz} < f_{max} \leq 10 \text{ kHz}$: $I \leq 20 \text{ mA}$ $R_L \leq 10 \text{ k}\Omega$ for $f \leq 1 \text{ kHz}$ $R_L \leq 1 \text{ k}\Omega$ for $f \leq 10 \text{ kHz}$ open: $I \leq 0.05 \text{ mA}$ closed: $U_{0, nom} = 22.5 \text{ V}$ at $I = 1 \text{ mA}$ $U_{0, nom} = 21.5 \text{ V}$ at $I = 10 \text{ mA}$ $U_{0, nom} = 19 \text{ V}$ at $I = 20 \text{ mA}$	

Passive	$U_{ext} \leq 32 \text{ VDC}$		-
	f_{max} in operating menu set to: $f_{max} \leq 100 \text{ Hz}$: $I \leq 100 \text{ mA}$ $R_{L, max} = 47 \text{ k}\Omega$ $R_{L, max} = (U_{ext} - U_0) / I_{max}$ open: $I \leq 0.05 \text{ mA}$ at $U_{ext} = 32 \text{ VDC}$ closed: $U_{0, max} = 0.2 \text{ V}$ at $I \leq 10 \text{ mA}$ $U_{0, max} = 2 \text{ V}$ at $I \leq 100 \text{ mA}$		
	f_{max} in operating menu set to: $100 \text{ Hz} < f_{max} \leq 10 \text{ kHz}$: $I \leq 20 \text{ mA}$ $R_L \leq 10 \text{ k}\Omega$ for $f \leq 1 \text{ kHz}$ $R_L \leq 1 \text{ k}\Omega$ for $f \leq 10 \text{ kHz}$ $R_{L, max} = (U_{ext} - U_0) / I_{max}$ open: $I \leq 0.05 \text{ mA}$ at $U_{ext} = 32 \text{ VDC}$ closed: $U_{0, max} = 1.5 \text{ V}$ at $I \leq 1 \text{ mA}$ $U_{0, max} = 2.5 \text{ V}$ at $I \leq 10 \text{ mA}$ $U_{0, max} = 5.0 \text{ V}$ at $I \leq 20 \text{ mA}$		
NAMUR	-	Passive to EN 60947-5-6 open: $I_{nom} = 0.6 \text{ mA}$ closed: $I_{nom} = 3.8 \text{ mA}$	Passive to EN 60947-5-6 open: $I_{nom} = 0.43 \text{ mA}$ closed: $I_{nom} = 4.5 \text{ mA}$
			$U_i = 30 \text{ V}$ $I_i = 100 \text{ mA}$ $P_i = 1 \text{ W}$ $C_i = 10 \text{ nF}$ $L_i = 0 \text{ mH}$

Status output / limit switch			
Function and settings	Adjustable as automatic measuring range conversion, display of flow direction, overflow, error, switching point		
	Valve control with activated dosing function		
Operating data	Basic I/Os	Modular I/Os	Ex i
Active	-	$U_{int} = 24 \text{ VDC}$ $I \leq 20 \text{ mA}$ $R_{L, max} = 47 \text{ k}\Omega$ open: $I \leq 0.05 \text{ mA}$ closed: $U_{0, nom} = 24 \text{ V}$ at $I = 20 \text{ mA}$	-
Passive	$U_{ext} \leq 32 \text{ VDC}$ $I \leq 100 \text{ mA}$ $R_{L, max} = 47 \text{ k}\Omega$ $R_{L, max} = (U_{ext} - U_0) / I_{max}$ open: $I \leq 0.05 \text{ mA}$ at $U_{ext} = 32 \text{ VDC}$ closed: $U_{0, max} = 0.2 \text{ V}$ at $I \leq 10 \text{ mA}$ $U_{0, max} = 2 \text{ V}$ at $I \leq 100 \text{ mA}$	$U_{ext} = 32 \text{ VDC}$ $I \leq 100 \text{ mA}$ $R_{L, max} = 47 \text{ k}\Omega$ $R_{L, max} = (U_{ext} - U_0) / I_{max}$ open: $I \leq 0.05 \text{ mA}$ at $U_{ext} = 32 \text{ VDC}$ closed: $U_{0, max} = 0.2 \text{ V}$ at $I \leq 10 \text{ mA}$ $U_{0, max} = 2 \text{ V}$ at $I \leq 100 \text{ mA}$	-
NAMUR	-	Passive to EN 60947-5-6 open: $I_{nom} = 0.6 \text{ mA}$ closed: $I_{nom} = 3.8 \text{ mA}$	Passive to EN 60947-5-6 open: $I_{nom} = 0.43 \text{ mA}$ closed: $I_{nom} = 4.5 \text{ mA}$ $U_i = 30 \text{ V}$ $I_i = 100 \text{ mA}$ $P_i = 1 \text{ W}$ $C_i = 10 \text{ nF}$ $L_i = 0 \text{ mH}$

Control input			
Function	Hold value of the outputs (e.g. for cleaning work), set value of the outputs to "zero", counter and error reset, stop counter, range conversion, zero calibration		
	Start of dosing when dosing function is activated.		
Operating data	Basic I/Os	Modular I/Os	Ex i
Active	-	$U_{int} = 24 \text{ VDC}$ Terminals open: $U_{0, nom} = 22 \text{ V}$ Terminals bridged: $I_{nom} = 4 \text{ mA}$ On: $U_0 \geq 12 \text{ V}$ with $I_{nom} = 1.9 \text{ mA}$ Off: $U_0 \leq 10 \text{ V}$ with $I_{nom} = 1.9 \text{ mA}$	-
Passive	$U_{ext} \leq 32 \text{ VDC}$ $I_{max} = 6.5 \text{ mA}$ at $U_{ext} \leq 24 \text{ VDC}$ $I_{max} = 8.2 \text{ mA}$ at $U_{ext} \leq 32 \text{ VDC}$ Contact closed (On): $U_0 \geq 8 \text{ V}$ with $I_{nom} = 2.8 \text{ mA}$ Contact open (Off): $U_0 \leq 2.5 \text{ V}$ with $I_{nom} = 0.4 \text{ mA}$	$U_{ext} \leq 32 \text{ VDC}$ $I_{max} = 9.5 \text{ mA}$ at $U_{ext} \leq 24 \text{ V}$ $I_{max} = 9.5 \text{ mA}$ at $U_{ext} \leq 32 \text{ V}$ Contact closed (On): $U_0 \geq 3 \text{ V}$ with $I_{nom} = 1.9 \text{ mA}$ Contact open (Off): $U_0 \leq 2.5 \text{ V}$ with $I_{nom} = 1.9 \text{ mA}$	$U_{ext} \leq 32 \text{ VDC}$ $I \leq 6 \text{ mA}$ at $U_{ext} = 24 \text{ V}$ $I \leq 6.6 \text{ mA}$ at $U_{ext} = 32 \text{ V}$ On: $U_0 \geq 5.5 \text{ V}$ or $I \geq 4 \text{ mA}$ Off: $U_0 \leq 3.5 \text{ V}$ or $I \leq 0.5 \text{ mA}$ $U_i = 30 \text{ V}$ $I_j = 100 \text{ mA}$ $P_i = 1 \text{ W}$ $C_i = 10 \text{ nF}$ $L_j = 0 \text{ mH}$
NAMUR	-	Active to EN 60947-5-6 Contact open: $U_{0, nom} = 8.7 \text{ V}$ Contact closed (On): $I_{nom} = 7.8 \text{ mA}$ Contact open (off): $U_{0, nom} = 6.3 \text{ V}$ with $I_{nom} = 1.9 \text{ mA}$ Identification for open terminals: $U_0 \geq 8.1 \text{ V}$ with $I \leq 0.1 \text{ mA}$ Identification for short circuited terminals: $U_0 \leq 1.2 \text{ V}$ with $I \geq 6.7 \text{ mA}$	-

PROFIBUS DP	
Description	Galvanically isolated acc. to IEC 61158
Profile version: 3.02	
Automatic data transmission rate recognition (max. 12 Mbaud)	
Bus address adjustable via local display at the measuring device	
Function blocks	6 x analogue input block, 3 x totaliser function block, 1 x transducer block, 1 x physical block
Output data	Volume flow, mass flow, velocity of sound, flow speed, gain, SNR, electronic temperature, power supply Diagnostic data (Further meas. values and diagnostic data is available via acyclic access)
PROFIBUS PA	
Description	Galvanically isolated acc. to IEC 61158
	Profile version: 3.02
	Current consumption: 10.5 mA
	Permissible bus voltage: 9...32 V; in Ex application 9...24 V
	Bus interface with integrated reverse polarity protection
	Typical error current FDE (Fault Disconnection Electronic): 4.3 mA
	Bus address adjustable via local display on the measuring device
Function blocks	6 x analogue input block, 3 x totaliser function block, 1 x transducer block, 1 x physical block
Output data	Volume flow, mass flow, velocity of sound, flow speed, gain, SNR, electronic temperature, power supply Diagnostic data (Further meas. values and diagnostic data is available via acyclic access)
FOUNDATION Fieldbus	
Description	Galvanically isolated acc. to IEC 61158
	Current consumption: 10.5 mA
	Permissible bus voltage: 9...32 V; in Ex application 9...24 V
	Bus interface with integrated reverse polarity protection
	Link Master function (LM) supported
	Tested with Interoperable Test Kit (ITK) version 6.0
Function blocks	4 x analogue input, 2 x integrator, 1 x PID
Output data	Volume flow, mass flow, flow speed, electronic temperature, velocity of sound, gain, SNR Diagnostic data
MODBUS	
Description	Modbus RTU, Master / Slave, RS485
Address range	1...247
Supported function codes	01, 02, 03, 04, 05, 08, 16, 43
Supported Baudrate	1200, 2400, 4800, 9600, 19200, 38400, 57600, 115200 Baud

Approvals and certificates

CE	
	This device fulfills the statutory requirements of the EC directives. The manufacturer certifies successful testing of the product by applying the CE mark.
Electromagnetic compatibility	Directive: 2004/108/EC, NAMUR NE21/04
	Harmonized standard: EN 61326-1 : 2006
Low voltage directive	Directive: 2006/95/EC
	Harmonized standard: EN 61010 : 2010
Pressure equipment directive	Directive: 97/23/EC
	Category I, II, III or SEP
	Fluid group 1, table 6
	Production module H
NAMUR	NE 21,43,53,80,107
Other approvals and standards	
Non-Ex	Standard
Hazardous areas	
Ex zone 1 - 2	For detailed information, please refer to the relevant Ex documentation.
	According to European Directive 94/9 EC (ATEX 100a)
IECEX	Approval number; IECEX DEK13.0023 X
ATEX	DEKRA 13ATEX0092X
cCSAus; class 1 Div. 1 and 2	Approval number; 2593926 [pending: amendment for CS/CS sensor material]
NEPSI	Approval number; GYJ13.1411X - 12X - 13X
DNV Inmetro	Approval number; DNV 13.0141 X
Protection category acc. to IEC 529 / EN 60529	Signal converter
	Compact (C): IP66/67 (NEMA 4X/6)
	Field (F): IP66/67 (NEMA 4X/6)
	All flow sensors
	IP67 (NEMA 6)
Shock resistance	Option: IP68 (NEMA 6P)
	IEC 68-2-27
Vibration resistance	30 g for 18 ms
	IEC 68-2-6; 1g up to 2000 Hz
	IEC 60721; 10g

2.2 Dimensions and weights

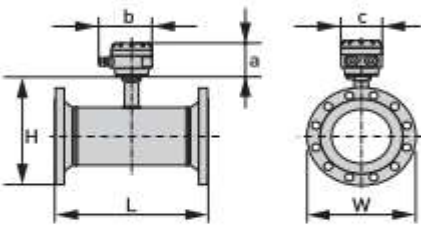
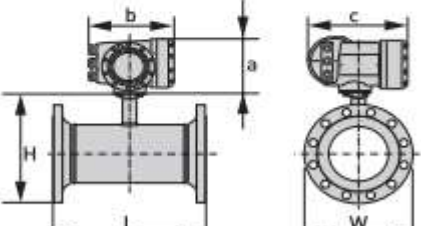
Remote version		a = 88 mm / 3.5" b = 139 mm / 5.5" ① c = 106 mm / 4.2" Total height = H + a ②
Compact version		a = 155 mm / 6.1" b = 230 mm / 9.1" ① c = 260 mm / 10.2" Total height = H + a ②

① The value may vary depending on the used cable glands.

② The value depends on version

2.2.1 Variants

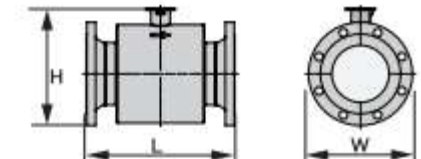
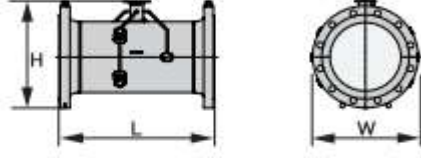
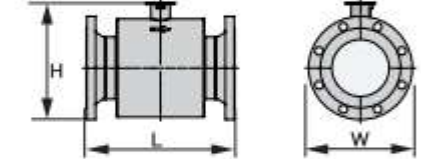
Standard version and Extended temperature - High Viscosity - Cryogenic versions; ≤ DN300 / 12"		DIN: L= 250...500 mm / 9.8"...19.7" ANSI: L= 250...500 mm / 9.8"...19.7" * for Cryo - HV - XXT versions; ANSI: L= 250...550 mm / 9.8"...21.7"
Standard version; ≥ DN350 / 14"		DIN: L= 500...600 mm / 19.7"...23.6" ANSI: L= 700...800 mm / 27.6"...31.5"
Extended temperature - High Viscosity - Cryogenic version; ≥ DN350 / 14"		DIN: L= 500...750 mm / 19.7"...29.5" ANSI: L= 700...850 mm / 27.6"...33.5"

For all dimensions and options; see tables on next pages [tables not final]

Note; the cCSA versions (DN25...65 / 1...2.5") are manufactured with a heavy duty neck (SS) which is 3.6 mm / 0.14 inch higher.

2.2.2 Standard flow sensor

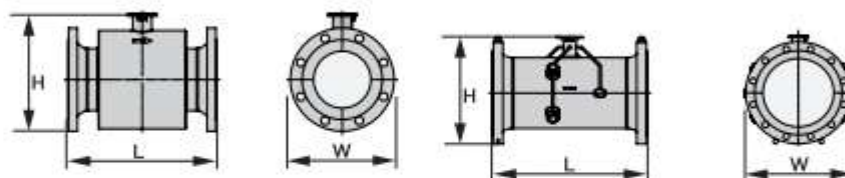

The following dimensions are applicable for the OPTISONIC 3400 in compact and remote versions;

EN1092-1; Standard variant - PN40

Nominal size	Dimensions [mm],					Approx weight [kg]	
	DN	L	H	W	Di CS	Di SS	CS
25	250	155	115	27	27	8	8
32	260	156	140	35	35	9	10
40	270	173	150	39	41	11	14
50	300	193	165	53	53	14	17
65	300	203	185	63	63	18	19
80	300	238	200	78	81	17	18
100	350	268	235	102	104	24	24
125	350	297	270	127	130	30	29
150	400	326	300	154	158	37	37
200	400	427	375	207	207	63	63
250	500	492	450	260	260	100	100
300	500	547	515	308	308	140	140

EN1092-1; Standard variant - PN25

Nominal size	Dimensions [mm]					Approximate weight [kg]	
	DN	L	H	W	Di CS	Di SS	CS
100	350	268	235	102	104	24	23
125	350	297	270	127	130	30	29
150	400	326	300	154	158	37	37
200	400	419	360	207	207	61	61
250	450	479	425	255	255	80	80
300	500	532	485	305	305	102	102
350	500	539	555	330	330	126	126
400	600	596	620	379	379	172	167
450	700	654	670	441	441	199	199
500	700	707	730	488	488	252	252
600	800	817	845	588	588	335	355

EN1092-1; Standard variant - PN16

Nominal size	Dimensions [mm]					Approximate weight [kg]	
	DN	L	H	W	Di CS	Di SS	CS
100	350	261	220	102	104	20	19
125	350	287	250	127	130	20	20
150	350	319	285	154	158	30	29
200	400	409	340	207	207	51	47
250	400	469	405	255	255	64	64
300	500	520	460	305	305	84	84

EN1092-1; Standard variant - PN10

Nominal size	Dimensions [mm]					Approximate weight [kg]	
	DN	L	H	W	Di CS	Di SS	CS
200	400	409	340	207	207	48	48
250	400	464	395	255	255	55	55
300	500	512	445	305	305	71	71
350	500	517	505	341	341	69	69
400	600	572	565	388	388	90	90
450	600	623	615	441	441	97	101
500	600	674	670	487	487	118	118
600	600	779	780	585	585	157	157

ASME 150 lb Standard variant

Nom. size	Dimensions						Inner diameter [Di]		Approximate weight			
	L		H		W		CS / SS ①		CS		SS	
	[inch]	[mm]	[inch]	[mm]	[inch]	[mm]	[inch]	[mm]	[lb]	kg]	[lb]	[kg]
1	9,8	250	6,0	152	4,3	108	1,1	27	20	9	22	10
1¼	10,2	260	6,3	161	4,6	117	1,4	35	22	10	22	10
1½	10,6	270	6,9	174	5,0	127	1,5 ①	39 ①	26	12	26	12
2	11,8	300	7,4	187	6,0	152	2,1	53	33	15	35	16
2½	11,8	300	8,7	221	7,0	178	2,5	63	42	19	44	20
3	13,8	350	9,2	233	7,5	191	3,1	78	44	20	44	20
4	13,8	350	10,4	265	9,0	229	4,0	102	57	26	60	27
5	13,8	350	11,4	289	10,0	254	5,0	128	71	32	73	33
6	15,7	400	12,4	316	11,0	279	6,1	154	88	40	90	41
8	15,7	400	16,1	408	13,5	343	8,0	203	110	50	108	49
10	19,7	500	18,5	470	16,0	406	10,0	255	161	73	150	68
12	19,7	500	20,9	531	19,0	483	12,0	305	214	97	209	95
14	27,6	700	20,9	531	21,0	533	13,3	337	260	118	249	113
16	31,5	800	23,2	589	23,5	597	15,3	388	342	155	315	143
18	31,5	800	25,0	635	25,0	635	17,2	438	406	184	348	158
20	31,5	800	27,2	692	27,5	699	19,3	489	489	222	448	203
24	31,5	800	31,5	801	32,0	813	23,0 ①	584 ①	761	345	591	268
28	35,4	900	35,8	909	36,5	927	27,1 ①	687 ①	1052	477	-	-
32	39,4	1000	40,4	1027	41,8	1061	30,8 ①	783 ①	1598	725	-	-
36	43,3	1100	39,5	1004	46,0	1168	34,8 ①	884 ①	2006	910	-	-
40	47,2	1200	48,9	1243	50,8	1289	38,6 ①	980 ①	2621	1189	-	-

① Inner Diameter SS differs from CS, consult KROHNE for more information

ASME 300 lb Standard variant

Nom. size	Dimensions						Inner diameter [Di]		Approximate weight			
	L		H		W		CS / SS ①		CS		SS	
	[inch]	[mm]	[inch]	[mm]	[inch]	[mm]	[inch]	[mm]	[lb]	[kg]	[lb]	[kg]
1	9,8	250	6,3	160	4,9	124	1,1	27	22	10	24	11
1¼	10,2	260	6,6	169	5,3	133	1,4	35	22	10	22	10
1½	10,6	270	6,9	175	6,1	155	1,6	41	31	14	31	14
2	11,8	300	7,6	194	6,5	165	2,1	53	35	16	37	17
2½	11,8	300	9,0	227	7,5	191	2,5	63	44	20	44	20
3	13,8	350	9,6	243	8,3	210	3,1	78	53	24	55	25
4	15,7	400	10,9	278	10,0	254	4,0	102	79	36	82	37
5	15,7	400	11,9	301	11,0	279	5,0	128	97	44	99	45
6	17,7	450	13,2	335	12,5	318	6,1	154	128	58	130	59
8	17,7	450	16,8	427	15,0	381	8,0	203	190	86	179	81
10	19,7	500	19,2	489	17,5	445	9.7 ①	248 ①	280	127	256	116
12	23,6	600	21,4	544	20,5	521	11.8 ①	299 ①	421	191	388	176
14	27,6	700	22,0	560	23,0	584	13.1 ①	333 ①	489	222	467	212
16	31,5	800	24,3	617	25,5	648	15,0	381	688	312	642	291
18	31,5	800	26,5	674	28,0	711	16,5 ①	419 ①	882	400	811	368
20	31,5	800	28,8	731	30,5	775	18,4 ①	467 ①	1065	483	955	433
24	31,5	800	33,5	852	36,0	914	22,1 ①	560 ①	1537	697	1413	641

① Inner Diameter SS differs from CS, consult KROHNE for more information

ASME 600 lb Standard variant

Nom. size	Dimensions						Inner diameter [Di]		Approximate weight			
	L		H		W		CS / SS ①		CS		SS	
	[inch]	[mm]	[inch]	[mm]	[inch]	[mm]	[inch]	[mm]	[lb]	[kg]	[lb]	[kg]
1	10,6	270	6,3	160	4,9	124	1,1	27	24	11	24	11
1¼	10,6	270	6,6	169	5,3	133	1,4	35	24	11	24	11
1½	11,4	290	7,4	189	6,1	155	1,5 ①	39 ①	33	15	33	15
2	13,0	330	7,6	194	6,5	165	2,1	53	40	18	40	18
2½	13,0	330	9,0	227	7,5	191	2,5	63	51	23	51	23
3	15,7	400	9,6	243	8,3	210	2,9	74	62	28	64	29
4	15,7	400	11,3	287	10,8	273	3,6 ①	92 ①	110	50	108	49
5	19,7	500	12,9	327	13,0	330	4,8	122	172	78	174	79
6	19,7	500	13,9	354	14,0	356	5,5 ①	140 ①	223	101	216	98
8	19,7	500	17,6	446	16,5	419	7,6	194	298	135	302	137
10	23,6	600	20,5	521	20,0	508	9,6	243	527	239	487	221
12	23,6	600	23,0	583	22,0	559	11,4	289	628	285	586	266
14	27,6	700	22,4	569	23,8	603	12,1 ①	308 ①	767	348	714	324
16	31,5	800	25,0	636	27,0	686	13,9 ①	354 ①	1093	496	1010	458
18	31,5	800	27,2	690	29,3	743	15,7 ①	398 ①	1338	607	1210	549
20	35,4	900	29,5	750	32,0	813	17,4 ①	443 ①	1757	797	1601	726
24	35,4	900	34,0	865	37,0	940	20,9 ①	532 ①	2480	1125	2238	1015

① Inner Diameter SS differs from CS, consult KROHNE for more information

ASME 900 lb Standard variant

Nom. size	Dimensions						Inner diameter [Di]		Approximate weight			
	L		H		W		CS / SS ①		CS		SS	
	[inch]	[mm]	[inch]	[mm]	[inch]	[mm]	[inch]	[mm]	[lb]	[kg]	[lb]	[kg]
1	11,8	300	7,2	183	5,9	149	1,1	27	②	②	24	11
1½	11,8	300	7,8	198	7,0	178	1,6	41	②	②	33	15
2	14,6	370	9,0	230	8,5	216	2,1	53	②	②	64	29
3	17,7	450	10,7	271	9,5	241	2,6 ①	67 ①	93	42	95	43
4	17,7	450	12,1	309	11,5	292	3,4 ①	87 ①	143	65	137	62
6	23,6	600	14,9	379	15,0	381	5,2 ①	132 ①	309	140	306	139
8	31,5	800	19,3	490	18,5	470	7,0 ①	178 ①	562	255	540	245
10	31,5	800	22,6	574	21,5	546	9,1 ①	230 ①	772	350	750	340
12	35,4	900	24,6	625	24,0	610	10,8 ①	273 ①	1080	490	1025	465
14	35,4	900	23,2	589	25,2	641	11,8 ①	300 ①	1213	550	1146	520
16	39,4	1000	25,4	646	27,7	705	13,6 ①	344 ①	1565	710	1433	650
18	39,4	1000	28,0	712	31,0	787	15,3 ①	387 ①	2050	930	1940	880
20	43,3	1100	30,4	773	33,8	857	17,0 ①	432 ①	2624	1190	2535	1150
24	51,2	1300	36,1	916	41,0	1041	20,4 ①	518 ①	4718	2140	4475	2030

① Inner Diameter SS differs from CS

② Consult KROHNE for more information

2.2.3 Variant flow sensor; XXT - High Viscosity and Cryogenic (SS) versions.

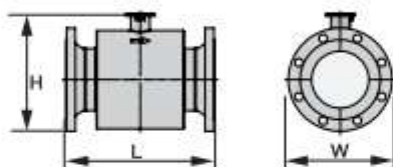

The following dimensions are applicable for the OPTISONIC 3400 in compact and remote versions;

EN1092-1; Extended temperature - High Viscosity and Cryogenic (SS) version - PN40

Nominal size	Dimensions [mm]					Approx weight [kg]	
	DN	L	H	W	Di CS	Di SS	CS
25	250	155	115	27	27	8	8
32	260	156	140	35	35	10	10
40	270	173	150	39	41	11	13
50	300	193	165	53	53	15	16
65	300	203	185	63	63	19	19
80	350	238	200	81	81	17	18
100	350	268	235	104	104	24	23
125	350	297	270	130	130	30	29
150	400	326	300	158	158	37	36
200	500	427	375	207	207	69	69
250	550	492	450	260	260	101	101
300	550	547	515	308	308	137	137

EN1092-1; Extended temperature - High Viscosity and Cryogenic (SS) version - PN25

Nominal size	Dimensions [mm]					Approximate weight [kg]	
	DN	L	H	W	Di CS	Di SS	CS
100	350	268	235	104	104	29	29
125	350	297	270	130	130	29	29
150	400	326	300	158	158	38	38
200	500	419	360	207	207	61	61
250	550	479	425	260	259	82	82
300	550	532	485	308	308	108	108
350	600	594	555	338	338	148	148
400	650	652	620	389	389	186	186
450	700	702	670	439	439	223	223
500	750	752	730	488	488	290	290
600	800	857	845	586	586	362	362

EN1092-1; Extended temperature - High Viscosity and Cryogenic (SS) version - PN16

Nominal size	Dimensions [mm]					Approximate weight [kg]	
	DN	L	H	W	Di CS	Di SS	CS
100	350	261	220	104	104	23	23
125	350	287	250	130	130	29	29
150	350	319	285	158	158	38	38
200	450	409	340	207	207	49	49
250	500	469	405	260	260	67	68
300	500	520	460	310	310	82	82

EN1092-1; Extended temperature - High Viscosity and Cryogenic (SS) version - PN10

Nominal size	Dimensions [mm]					Approximate weight [kg]	
	DN	L	H	W	Di CS	Di SS	CS
200	450	409	340	207	207	50	50
250	500	512	445	260	260	66	66
300	500	512	445	310	310	75	75
350	500	559	505	342	342	91	91
400	600	594	565	393	393	114	114
450	600	674	615	443	443	130	130
500	650	722	670	494	494	151	151
600	700	824	780	594	594	195	195
700	750	929	895	694	③	280	③
800	900	1039	1015	794	③	380	③
900	900	1137	1115	889	③	469	③
1000	1000	1247	1230	991	③	595	③

③ TBD - Consult KROHNE for more information

ASME 150 lb - Extended temperature - High Viscosity and Cryogenic versions

Nom. size	Dimensions						Inner diameter [Di]		Approximate weight			
	L		H		W		CS / SS ①		CS		SS	
	[inch]	[mm]	[inch]	[mm]	[inch]	[mm]	[inch]	[mm]	[lb]	[kg]	[lb]	[kg]
1	9,8	250	6,0	152	4,3	108	1,1	27	20	9	20	9
1¼	10,2	260	6,3	161	4,6	117	1,4	35	24	11	22	10
1½	10,6	270	6,9	174	5,0	127	1,6	41	26	12	24	11
2	11,8	300	7,4	187	6,0	152	2,1	53	33	15	33	15
2½	11,8	300	8,7	221	7,0	178	2,5	63	42	19	42	19
3	13,8	350	9,2	233	7,5	191	3,1	78	44	20	44	20
4	13,8	350	10,4	265	9,0	229	4,0	102	57	26	57	26
5	13,8	350	11,4	289	10,0	254	5,0	128	71	32	71	32
6	15,7	400	12,4	316	11,0	279	6,1	154	88	40	88	40
8	17,7	450	16,1	408	13,5	343	8,0	203	119	54	115	52
10	21,7	550	18,5	470	16,0	406	10,0	255	168	76	159	72
12	21,7	550	20,9	531	19,0	483	12,0	305	216	99	216	99
14	27,6	700	20,9	531	21,0	533	13,3	337	311	141	298	135
16	31,5	800	23,2	589	23,5	597	15,3	388	399	181	373	169
18	31,5	800	25,0	635	25,0	635	17,2	438	470	213	414	188
20	31,5	800	27,2	692	27,5	699	19,3	489	560	254	518	235
24	33,5	850	31,5	801	32,0	813	23,3	591	869	394	692	314
28	35,4	900	37,2	945	36,5	927	27,1 ①	687 ①	1052	527	-	-
32	37,4	950	41,8	1062	41,8	1061	30,8 ①	783 ①	1598	769	-	-
36	41,3	1050	45,8	1163	46,0	1168	34,8 ①	884 ①	2006	963	-	-
40	43,3	1100	50,2	1276	50,8	1289	38,6 ①	980 ①	2621	1225	-	-

① Inner Diameter SS differs from CS, consult KROHNE for more information

ASME 300 lb - Extended temperature - High Viscosity and Cryogenic versions.

Nom. size	Dimensions						Inner diameter [Di]		Approximate weight			
	L		H		W		CS / SS ①		CS		SS	
	[inch]	[mm]	[inch]	[mm]	[inch]	[mm]	[inch]	[mm]	[lb]	[kg]	[lb]	[kg]
1	9,8	250	6,3	160	4,9	124	1,1	27	22	10	22	10
1¼	10,2	260	6,6	169	5,3	133	1,4	35	24	11	22	10
1½	10,6	270	6,9	175	6,1	155	1,6	41	31	14	29	13
2	11,8	300	7,6	194	6,5	165	2,1	53	35	16	35	16
2½	11,8	300	9,0	227	7,5	191	2,5	63	44	20	44	20
3	13,8	350	9,6	243	8,3	210	3,1	78	53	24	53	24
4	15,7	400	10,9	278	10,0	254	4,0	102	79	36	79	36
5	15,7	400	11,9	301	11,0	279	5,0	128	97	44	97	44
6	17,7	450	13,2	335	12,5	318	6,1	154	128	58	128	58
8	19,7	500	16,8	427	15,0	381	8,0 ①	203 ①	203	92	187	85
10	21,7	550	19,2	489	17,5	445	9.7 ①	248 ①	288	135	265	120
12	23,6	600	21,4	544	20,5	521	11.8 ①	299 ①	428	194	392	178
14	27,6	700	24,0	609	23,0	584	13.1 ①	333 ①	536	243	518	235
16	31,5	800	26,2	665	25,5	648	15,0	381	699	317	697	316
18	31,5	800	28,4	722	28,0	711	16,5 ①	419 ①	941	427	871	395
20	31,5	800	30,5	774	30,5	775	18,4 ①	467 ①	1131	513	1023	464
24	33,5	850	34,8	884	36,0	914	22,1 ①	560 ①	1658	752	1530	694

① Inner Diameter SS differs from CS, consult KROHNE for more information

ASME 600 lb - Extended temperature - High Viscosity and Cryogenic versions.

Nom. size	Dimensions						Inner diameter [Di]		Approximate weight			
	L		H		W		CS / SS ①		CS		SS	
	[inch]	[mm]	[inch]	[mm]	[inch]	[mm]	[inch]	[mm]	[lb]	[kg]	[lb]	[kg]
1	10,6	270	6,3	160	4,9	124	1,1	27	24	11	24	11
1¼	10,6	270	6,6	169	5,3	133	1,4	35	24	11	24	11
1½	11,4	290	7,4	189	6,1	155	1,5 ①	39 ①	33	15	33	15
2	13,0	330	7,6	194	6,5	165	2,1	53	40	18	40	18
2½	13,0	330	9,0	227	7,5	191	2,5	63	51	23	51	23
3	15,7	400	9,6	243	8,3	210	2,9	74	62	28	62	28
4	15,7	400	11,3	287	10,8	273	3,6 ①	92 ①	110	50	108	49
5	19,7	500	12,9	327	13,0	330	4,8	122	172	78	172	78
6	19,7	500	13,9	354	14,0	356	5,5 ①	140 ①	223	101	216	98
8	21,7	550	17,6	446	16,5	419	7,6	194	320	145	313	142
10	25,6	650	20,5	521	20,0	508	9,3 ①	236 ①	536	243	503	228
12	27,6	700	23,0	583	22,0	559	11,1 ①	281 ①	679	308	631	286
14	29,5	750	24,3	618	23,8	603	12,1 ①	308 ①	842	382	789	358
16	31,5	800	26,9	684	27,0	686	13,9 ①	354 ①	1155	524	1074	487
18	33,5	850	29,1	738	29,3	743	15,7 ①	398 ①	1442	654	1307	593
20	35,4	900	31,2	793	32,0	813	17,4 ①	443 ①	1832	831	1682	763
24	37,4	950	35,3	896	37,0	940	20,9 ①	532 ①	2630	1193	2383	1081

① Inner Diameter SS differs from, consult KROHNE for more information

ASME 900 lb - Extended temperature, High Viscosity and *Cryogenic versions.

Nom. size	Dimensions						Inner diameter [Di]		Approximate weight			
	L		H		W		CS / SS ①		CS		SS	
	[inch]	[mm]	[inch]	[mm]	[inch]	[mm]	[inch]	[mm]	[lb]	[kg]	[lb]	[kg]
3	17,7	450	10,7	271	9,5	241	2,6 ①	67 ①	93	42	93	42
4	17,7	450	12,1	309	11,5	292	3,4 ①	87 ①	143	65	141	64
6	23,6	600	14,9	379	15,0	381	5,2 ①	132 ①	309	140	304	138
8	31,5	800	18,6	472	18,5	470	7,0 ①	178 ①	540	245	503	228
10	31,5	800	21,6	550	21,5	546	8,5 ①	216 ①	809	367	756	343
12	35,4	900	24,0	609	24,0	610	10,1 ①	257 ①	1129	512	994	451
14	35,4	900	25,1	637	25,2	641	11,2 ①	284 ①	1303	591	1162	527
16	39,4	1000	27,3	694	27,7	705	13,1 ①	333 ①	1627	738	1517	688
18	39,4	1000	29,9	760	31,0	787	14,9 ①	378 ①	2112	958	2022	917
20	39,4	1000	32,6	828	33,8	857	16,5 ①	419 ①	2599	1179	2399	1088
24	51,2	1300	37,6	955	41,0	1041	19,9 ①	505 ①	4830	2191	4482	2033

① Inner Diameter SS differs from CS, consult KROHNE for more information

*Cryogenic and XXT versions not available for 8"…24"

2.2.4 Signal converter housing

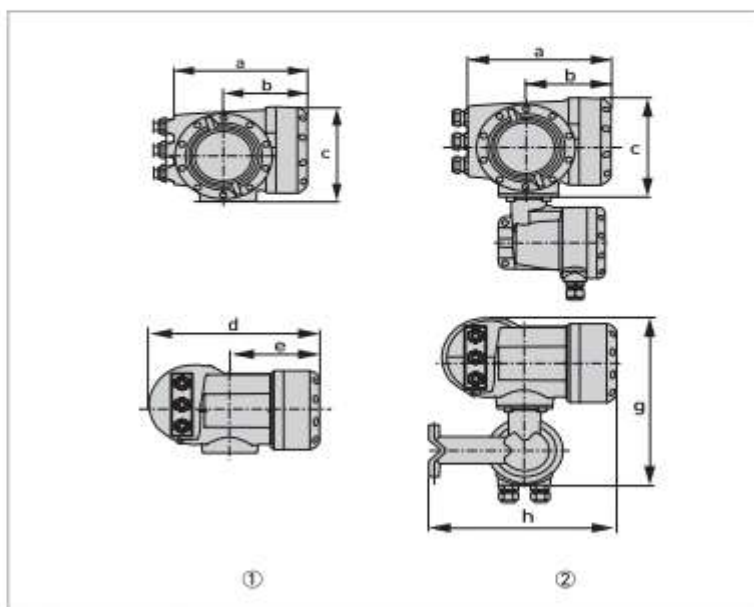

- ① Compact housing (C)
 ② Field housing (F)

Dimensions and weights in mm and kg

Version	Dimensions [mm]							Weight [kg]
	a	b	c	d	e	g	h	
C	202	120	155	260	137	-	-	4.2
F	202	120	155	-	-	295.8	277	5.7

Dimensions and weights in inch and lb

Version	Dimensions [inch]							Weight [lb]
	a	b	c	d	e	g	h	
C	7.75	4.75	6.10	10.20	5.40	-	-	9.30
F	7.75	4.75	6.10	-	-	11.60	10.90	12.60

3.1 Intended use

Responsibility for the use of the measuring devices with regard to suitability, intended use and corrosion resistance of the used materials against the measured fluid lies solely with the operator.

The manufacturer is not liable for any damage resulting from improper use or use for other than the intended purpose.

The **OPTISONIC 3400** is designed exclusively for measurements on conductive and / or non-conductive fluids, in closed completely filled pipeline circuits. Excess of contaminations (gas, particles, 2 phases) disturb the acoustic signal and thus must be avoided.

The overall functionality of the **OPTISONIC 3400** flowmeter, is the continuous measurement of actual volume flow, mass flow, flow speed, velocity of sound, gain, SNR, totalized flow mass and diagnosis values.

3.2 General notes on installation

Inspect the packaging carefully for damages or signs of rough handling. Report damage to the carrier and to the local office of the manufacturer.

Do a check of the packing list to make sure that you have all the elements given in the order.

Look at the device nameplate to ensure that the device is delivered according to your order. Check for the correct supply voltage printed on the nameplate.

3.3 Vibration

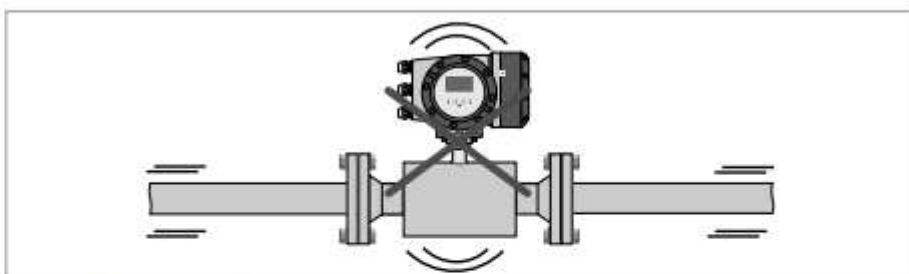

Figure 3-1: Avoid vibrations

In case of expected vibrations, please install a field version.

3.4 Installation requirements signal converter

- Allow 10...20 cm / 3.9...7.9" of space at the sides and rear of the signal converter to permit free air circulation.
- Protect signal converter against direct solar radiation, install a sunshield if necessary.
- Signal converters installed in switchgear cabinets require adequate cooling, e.g. by fan or heat exchanger.
- Do not expose the signal converter to intense vibration.

3.5 Installation conditions

3.5.1 Inlet and outlet

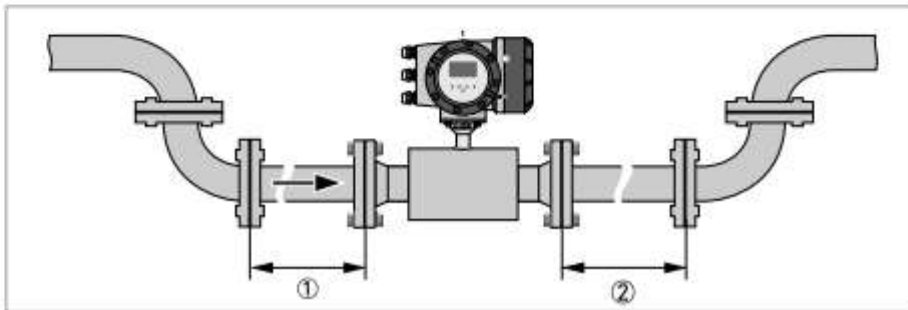

Figure 3-2: Recommended inlet and outlet

- ① Refer to chapter "Bends in 2 or 3 dimensions"
- ② ≥ 3 DN

3.5.2 Bends in 2 or 3 dimensions

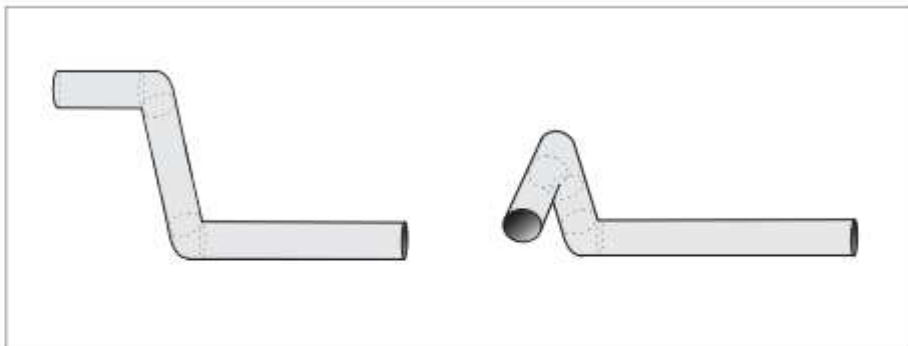

Figure 3-3: 2 and 3 dimensional bends, in front of flowmeter

- ① Bends in 2 dimensions: ≥ 5 DN; bends in 3 dimensions: ≥ 10 DN

3.5.3 T-section

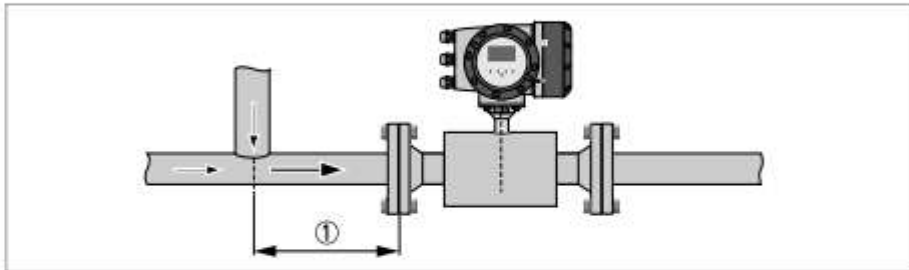

Figure 3-4: Distance behind a T-section

① $\geq 5 \text{ DN}$

3.5.4 Bends

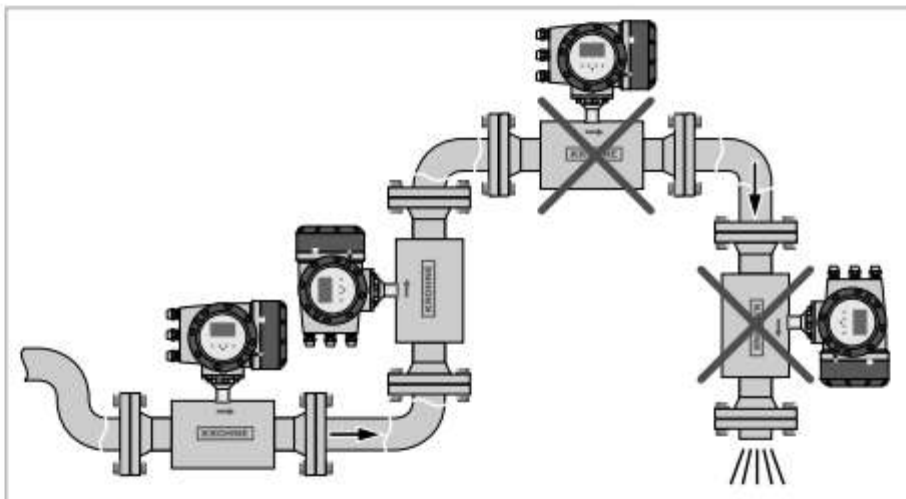

Figure 3-5: Installation in bending pipes

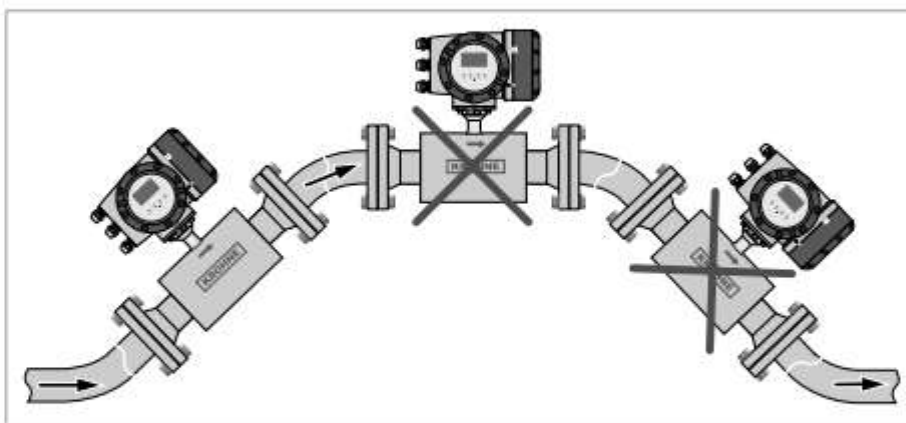

Figure 3-6: Installation in bending pipes

3.5.5 Open feed or discharge

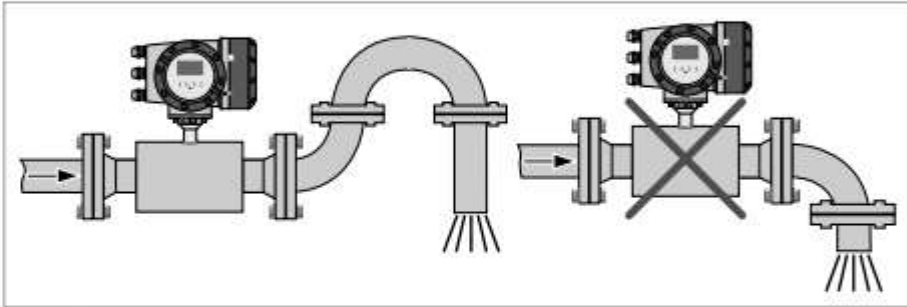

Figure 3-7: Open discharge

Install meter on a lowered section of the pipe to ensure a full pipe condition through the meter.

3.5.6 Position of pump

Never install flowmeter at a pump suction side in order to avoid cavitation or flashing in the flowmeter.

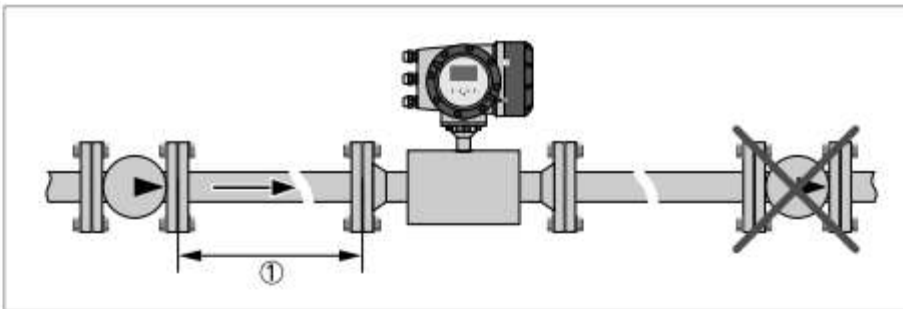

Figure 3-8: Position of pump

① ≥ 15 DN

3.5.7 Control valve

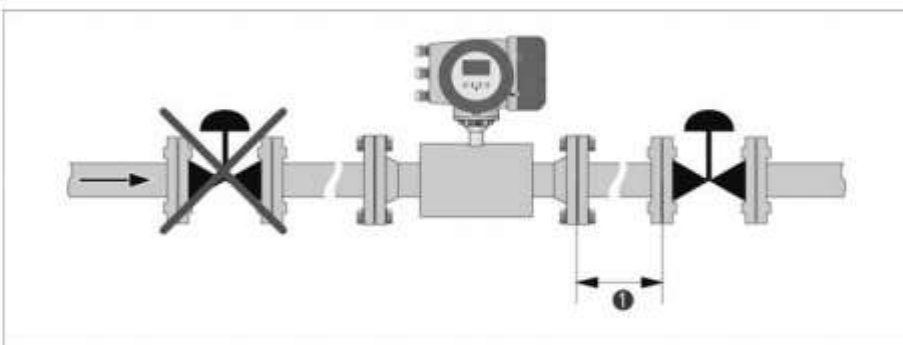

Figure 3-9: Installation in front of a control valve

① ≥ 20 DN

3.5.8 Down going pipeline over 5 m / 16 ft length

Install air vent downstream of the flowmeter to prevent vacuum. Although this will not harm the meter, it may cause gases to come out of solution (cavitate) and interfere with proper measurements.

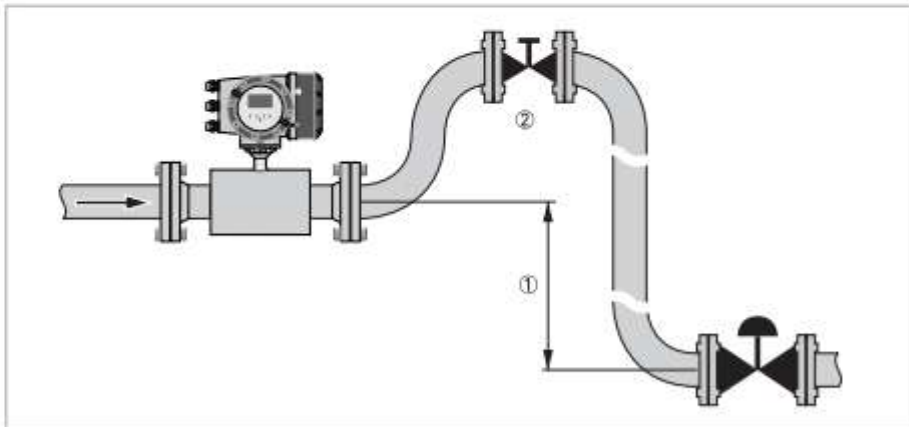

Figure 3-10: Down going pipeline over 5 m / 16 ft length

- ① ≥ 5 m / 16 ft
- ② Install air vent

3.5.9 Insulation

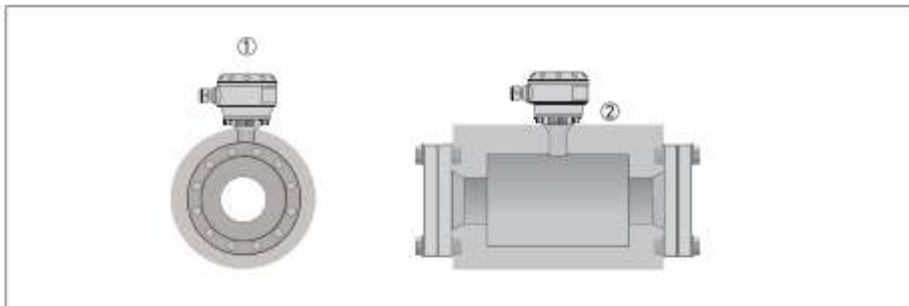

Figure 3-11: Insulation

- ① Connection box
- ② Insulation area

*The flow sensor can be insulated completely, except for the connection box.
(Ex: maximum temperature, refer to Ex supplement)*

For devices used in hazardous area, additional maximum temperature and insulation precautions apply. Please refer to the Ex documentation!

3.5.10 Mounting

3.5.11 Flange deviation

Max. permissible misalignment of pipe flange faces: M_{max} 0.5 degree, according ASME B16.5 Individual flanges. See Appendix 12 ; Flange face alignment of the General Piping Requirements DEP 31.38.01.11-GEN

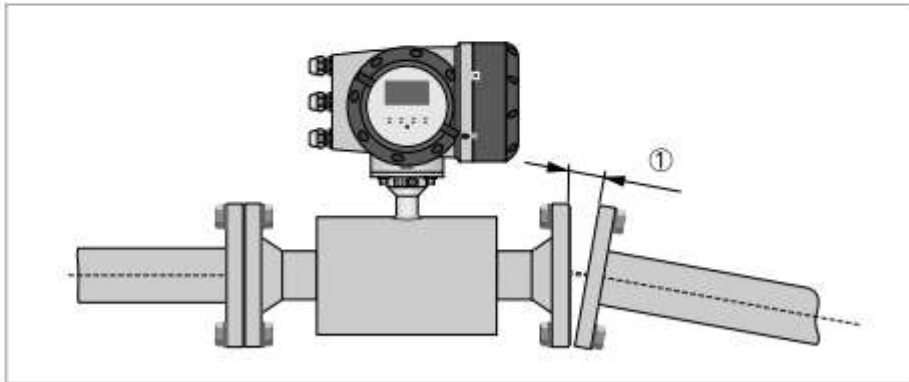

Figure 3-12: Flange deviation

① M_{max}

3.5.12 Mounting position

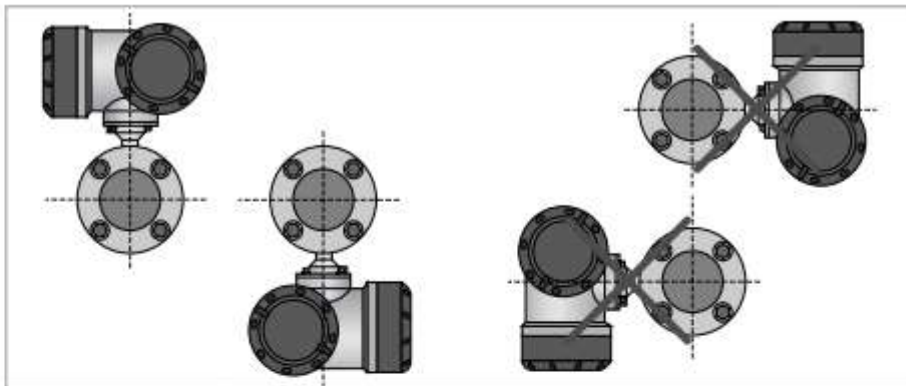

Figure 3-13: Horizontal and vertical mounting

4.1 Safety instructions

All work on the electrical connections may only be carried out with the power disconnected. Take note of the voltage data on the nameplate!

Observe the national regulations for electrical installations!

For devices used in hazardous areas, additional safety notes apply; please refer to the Ex documentation.

Observe without fail the local occupational health and safety regulations. Any work done on the electrical components of the measuring device may only be carried out by properly trained specialists.

Look at the device nameplate to ensure that the device is delivered according to your order. Check for the correct supply voltage printed on the nameplate.

4.2 Signal cable (remote versions only)

The flow sensor is connected to the signal converter via one signal cable, with 6 (labeled) inner coax cables for the connection of three acoustic paths.

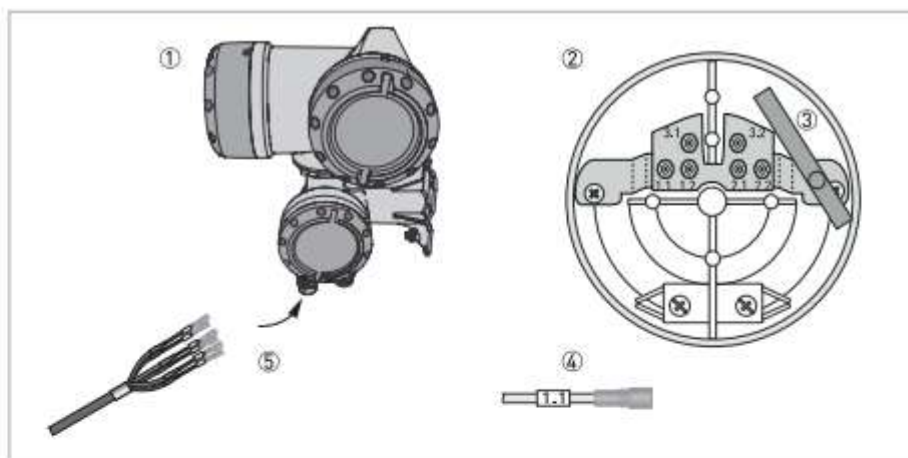

Figure 4-1: Construction of field version

- ① Signal converter
- ② Open connection box
- ③ Tool for releasing connectors
- ④ Marking on cable
- ⑤ Insert cable(s) into terminal compartment

Connect the cable on connector with similar numeral marking

4.3 Power supply

When this device is intended for permanent connection to the mains.

It is required (for example for service) to mount an external switch or circuit breaker near the device for disconnection from the mains. It shall be easily reachable by the operator and marked as the disconnecting the device for this equipment.

The switch or circuit breaker and wiring has to be suitable for the application and shall also be in accordance with the local (safety) requirements of the (building) installation (e.g. IEC 60947-1 / -3)

For devices used in hazardous areas, additional safety notes apply; please refer to the Ex documentation.

The power terminals in the terminal compartments are equipped with additional hinged lids to prevent accidental contact.

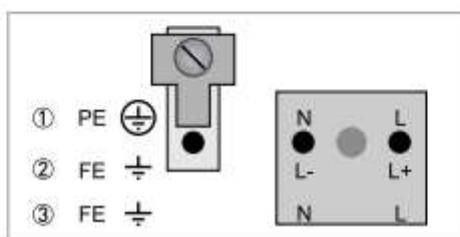

- ① 100...230 VAC [-15% / +10%], 22 VA
- ② 24 VDC [-55% / +30%], 12 W
- ③ 24 VAC/DC (AC: -15% / +10%; DC: -25% / +30%), 22 VA or 12 W

The device must be grounded in accordance with regulations in order to protect personnel against electric shocks.

100...230 VAC (tolerance range: -15% / +10%)

- Note the power supply voltage and frequency (50...60 Hz) on the nameplate.
- The protective ground terminal **PE** of the power supply must be connected to the separate U-clamp terminal in the terminal compartment of the signal converter

240 VAC+5% is included in the tolerance range.

24 VDC (tolerance range: -55% / +30%)

24 VAC/DC (tolerance ranges: AC: -15% / +10%; DC: -25% / +30%)

- Note the data on the nameplate!
- For measurement process reasons, a functional ground **FE** must be connected to the separate U-clamp terminal in the terminal compartment of the signal converter.
- When connecting to functional extra-low voltages, provide a facility for protective separation (PELV) (acc. to VDE 0100 / VDE 0106 and/or IEC 364 / IEC 536 or relevant national regulations).

For 24 VDC, 12 VDC-10% is included in the tolerance range.

4.4 Inputs and outputs, overview

4.4.1 Combinations of the inputs/outputs (I/Os)

This signal converter is available with various input/output combinations.

Basic version

- Has 1 current output, 1 pulse output and 2 status outputs / limit switches.
- The pulse output can be set as status output/limit switch and one of the status outputs as a control input.

Ex i version

- Depending on the task, the device can be configured with various output modules.
- Current outputs can be active or passive.
- Optionally available also with Foundation Fieldbus and Profibus PA.

Modular version

- Depending on the task, the device can be configured with various output modules.

Bus systems

- The device allows intrinsically safe and non intrinsically safe bus interfaces in combination with additional modules.
- For connection and operation of bus systems, please note the separate documentation.

Ex option

- For hazardous areas, all of the input/output variants for the housing designs C and F with terminal compartment in the Ex d (pressure-resistant casing) or Ex e (increased safety) versions can be delivered.
- Please refer to the separate instructions for connection and operation of the Ex-devices.

4.4.2 Description of the CG number

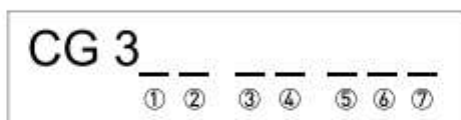

Figure 4-2: Marking [CG number] of the electronics module and input/output variants

- ① ID number:
- ② ID number: 0 = standard
- ③ Power supply option
- ④ Display (language versions)
- ⑤ Input/output version (I/O)
- ⑥ 1st optional module for connection terminal A
- ⑦ 2nd optional module for connection terminal B

The last 3 digits of the CG number (⑤, ⑥ and ⑦) indicate the assignment of the terminal connections. Please refer to the following examples.

Examples for CG number

CG 350 x1 100	100...230 VAC & standard display; basic I/O: I_a or I_p & S_p/C_p & S_p & P_p/S_p
CG 350 x1 7FK	100...230 VAC & standard display; modular I/O: I_a & P_N/S_N and optional module P_N/S_N & C_N
CG 350 x1 4EB	24 VDC & standard display; modular I/O: I_a & P_a/S_a and optional module P_p/S_p & I_p

Description of abbreviations and CG identifier for possible optional modules on terminals A and B

Abbreviation	Identifier for CG No.	Description
I_a	A	Active current output
I_p	B	Passive current output
P_a / S_a	C	Active pulse output, frequency output, status output or limit switch (changeable)
P_p / S_p	E	Passive pulse output, frequency output, status output or limit switch (changeable)
P_N / S_N	F	Passive pulse output, frequency output, status output or limit switch acc. to NAMUR (changeable)
C_a	G	Active control input
C_p	K	Passive control input
C_N	H	Active control input to NAMUR Signal converter monitors cable breaks and short circuits acc. to EN 60947-5-6. Errors indicated on LC display. Error messages possible via status output.
-	8	No additional module installed
-	0	No further module possible

4.4.3 Fixed, non-alterable input/output versions

This signal converter is available with various input/output combinations.

- The grey boxes in the tables denote unassigned or unused connection terminals.
- In the table, only the final digits of the CG no. are depicted.
- Connection terminal A+ is only operable in the basic input/output version.

CG-No.	Connection terminals								
	A+	A	A-	B	B-	C	C-	D	D-

Basic in-/output (I/O) (Standard)

1 0 0		I_p + HART® passive ①	S_p / C_p passive ②	S_p passive	P_p / S_p passive ②
		I_a + HART® active ①			

Ex-i in-/outputs (Option)

2 0 0				I_a + HART® active	P_N / S_N NAMUR ②
3 0 0				I_p + HART® passive	P_N / S_N NAMUR ②
2 1 0		I_a active	P_N / S_N NAMUR C_p passive ②	I_a + HART® active	P_N / S_N NAMUR ②
3 1 0		I_a active	P_N / S_N NAMUR C_p passive ②	I_p + HART® passive	P_N / S_N NAMUR ②
2 2 0		I_p passive	P_N / S_N NAMUR C_p passive ②	I_a + HART® active	P_N / S_N NAMUR ②
3 2 0		I_p passive	P_N / S_N NAMUR C_p passive ②	I_p + HART® passive	P_N / S_N NAMUR ②

① Function changed by reconnecting

② Changeable

4.4.4 Alterable input/output versions

This signal converter is available with various input/output combinations.

- The grey boxes in the tables denote unassigned or unused connection terminals.
- In the table, only the final digits of the CG no. are depicted.
- Term. = [connection] terminal

CG no.	Connection terminals								
	A+	A	A-	B	B-	C	C-	D	D-

Modular IOs (option)

4 __		max. 2 optional modules for term. A + B	I _a + HART® active	P _a / S _a active ①
8 __		max. 2 optional modules for term. A + B	I _p + HART® passive	P _a / S _a active ①
6 __		max. 2 optional modules for term. A + B	I _a + HART® active	P _p / S _p passive ①
B __		max. 2 optional modules for term. A + B	I _p + HART® passive	P _p / S _p passive ①
7 __		max. 2 optional modules for term. A + B	I _a + HART® active	P _N / S _N NAMUR ①
C __		max. 2 optional modules for term. A + B	I _p + HART® passive	P _N / S _N NAMUR ①

PROFIBUS PA/DP

D __		max. 2 optional modules for term. A + B	PA+ [2]	PA- [2]	PA+ [1]	PA- [1]
F __		max. 2 optional modules for term. A + B	PA+ [2]	PA- [2]	PA+ [1]	PA- [1]

FOUNDATION Fieldbus (option)

E __		max. 2 optional modules for term. A + B	V/D+ [2]	V/D- [2]	V/D+ [1]	V/D- [1]
------	--	---	----------	----------	----------	----------

Modbus (option)

G __ ②		max. 2 optional modules for term. A + B		Commo n	Sign. B [D1]	Sign. A [D0]
--------	--	---	--	------------	-----------------	-----------------

① changeable

② not activated bus terminator

Please fill in this form and fax or email it to your local representative. Please include a sketch of the pipe layout as well, including the X, Y, Z dimensions.

5.1 Device Configuration Form

Customer information:

Date:
Submitted by:
Company:
Address:
Telephone:
Fax:
E-mail:

Flow application data:

Reference information (name, tag etc):
New application Existing application, currently using:
Measurement objective:
Medium
Liquid:
Gas content:
Solids content:
Density:
Velocity of sound:
Flowrate
Normal:
Minimum:
Maximum:
Temperature
Normal:
Minimum:
Maximum:
Pressure
Normal:
Minimum:
Maximum:

Piping details

Nominal pipe size:
Outer diameter:
Wall thickness / schedule:
Pipe material:
Straight inlet / outlet section (DN):
Upstream situation (elbows, valves, pumps):
Flow orientation (vertical up / horizontal / vertical down / other):

Environment details

Corrosive atmosphere:
Sea water:
High humidity (% R.H.)
Nuclear (radiation):
Hazardous area:
Additional details:

Hardware requirements:

Accuracy requested (percentage of rate):
Power supply (voltage, AC / DC):
Analog output (4-20 mA)
Pulse (specify minimum pulse width, pulse value):
Digital protocol:
Options:
Remote mounted signal converter:
Specify cable length:
Accessories:

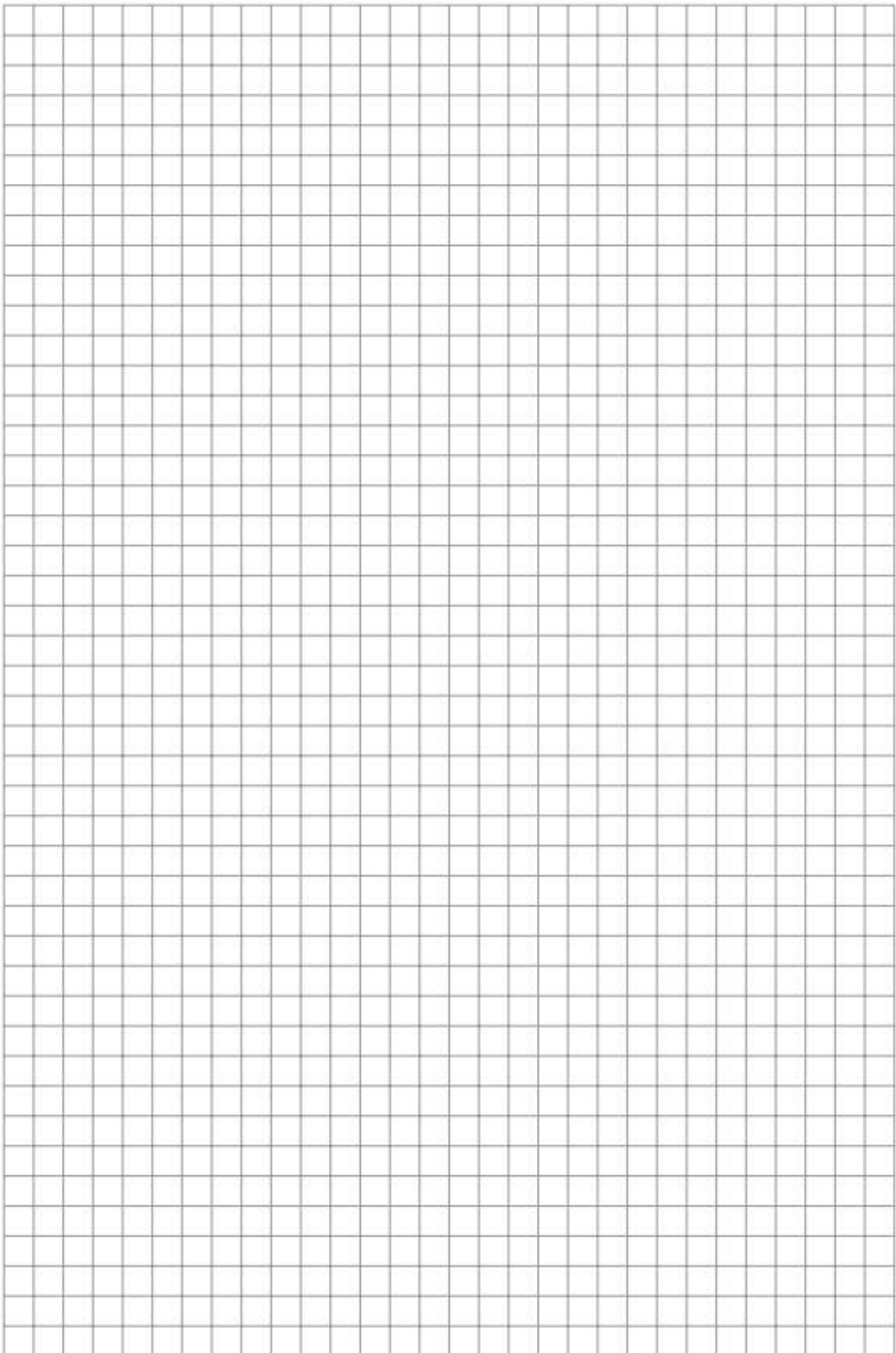

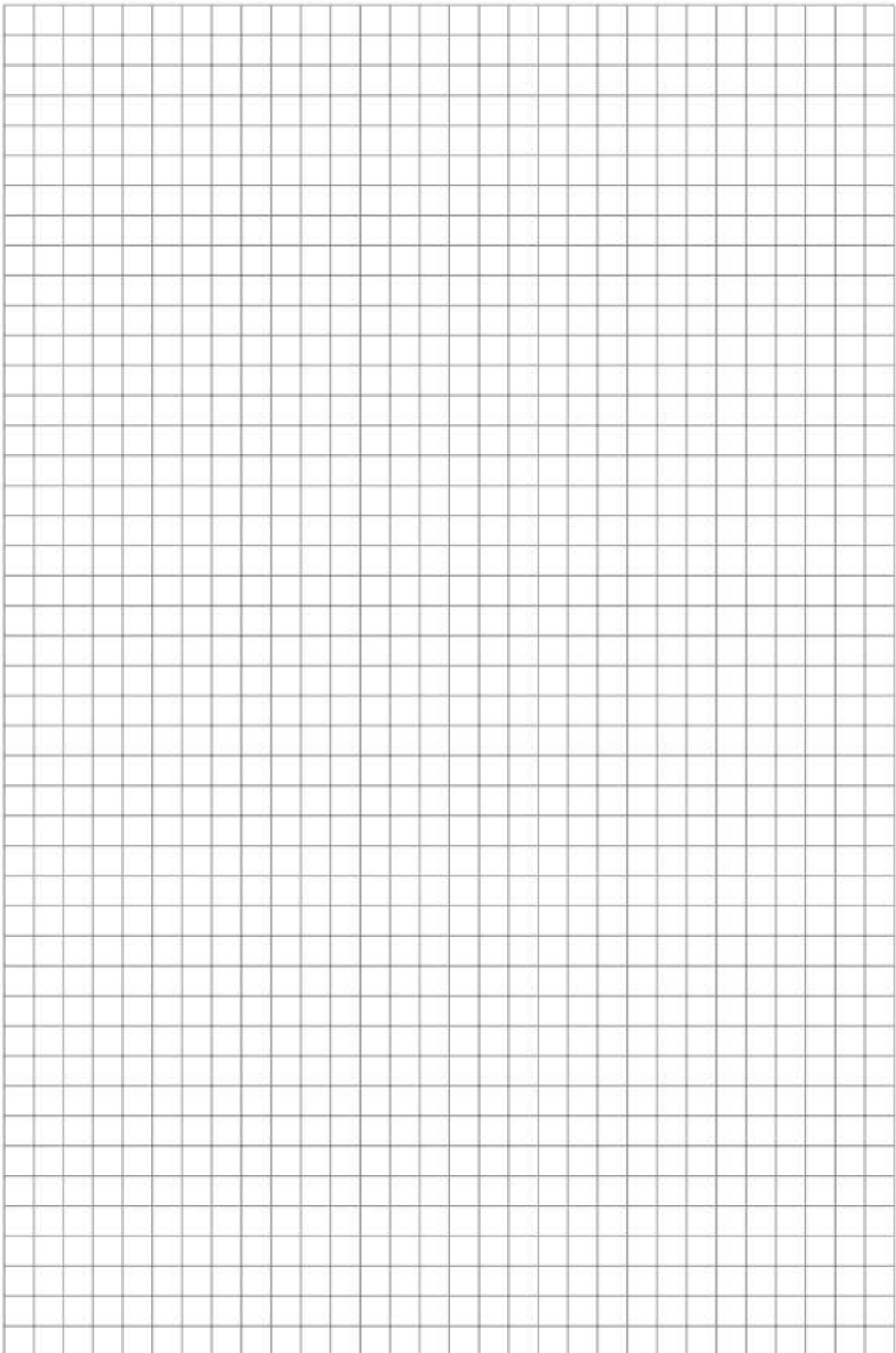

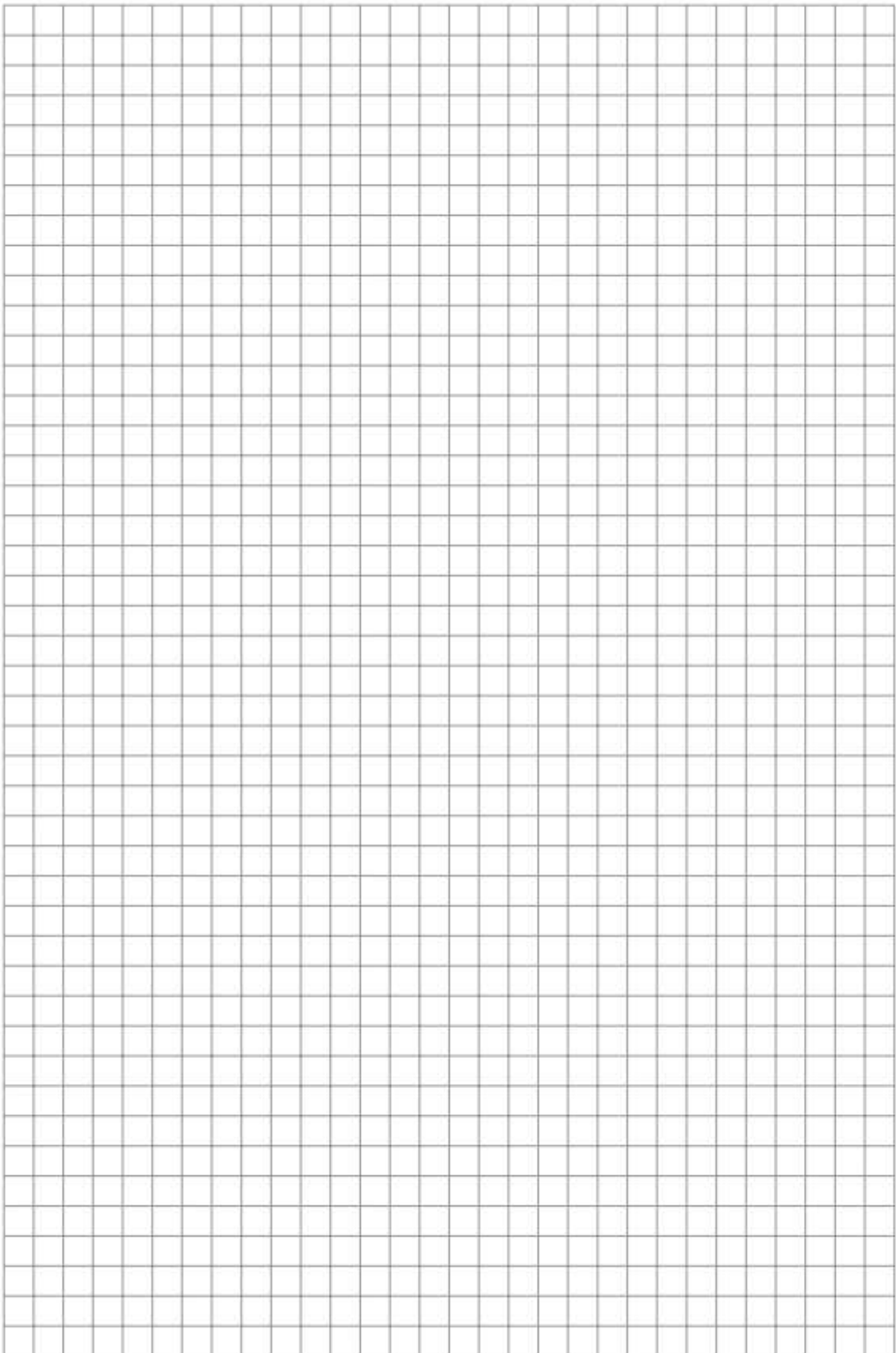



KROHNE product overview

- Electromagnetic flowmeters
- Variable area flowmeters
- Ultrasonic flowmeters
- Mass flowmeters
- Vortex flowmeters
- Flow controllers
- Level meters
- Temperature assemblies
- Pressure transmitters
- Analysis products
- Products and systems for the oil & gas industry
- Measuring systems for the marine industry

Head Office KROHNE Messtechnik GmbH
Ludwig-Krohne-Str. 5
47058 Duisburg (Germany)
Tel.: +49 203 301 0
Fax: +49 203 301 103 89
info@krohne.com

The current list of all KROHNE contacts and addresses can be found at:
www.krohne.com

KROHNE