



OPTIFLUX 6000 **Technical Datasheet**

Electromagnetic flow sensor
for hygienic and sanitary applications

- Robust stainless steel housing for hygienic and aseptic operation
- Fully suitable for CIP and SIP
- Typical food & beverage and pharmaceutical process connections and insertion lengths



The documentation is only complete when used in combination with the relevant documentation for the signal converter.

1	Product features	3
1.1	Sanitary and hygienic solution	3
1.2	Options	5
1.3	Measuring principle	7
2	Technical data	8
2.1	Technical data	8
2.2	Dimensions and weights	12
2.3	Measuring accuracy	26
3	Installation	28
3.1	Intended use	28
3.2	General notes on installation	28
3.2.1	Vibration	28
3.2.2	Magnetic field	28
3.3	Installation conditions	29
3.3.1	Inlet and outlet	29
3.3.2	Bends in 2 or 3 dimensions	29
3.3.3	T-section	30
3.3.4	Bends	30
3.3.5	Open discharge	31
3.3.6	Control valve	31
3.3.7	Pump	31
3.3.8	Air venting and vacuum forces	32
3.3.9	Mounting requirements for self-draining	33
3.3.10	Flange deviation	34
3.3.11	Mounting position	34
3.4	Mounting	35
3.4.1	Torques and pressures	35
3.4.2	Installation of weld-on versions	36
3.4.3	Temperatures	37
3.4.4	Cleaning	37
4	Electrical connections	38
4.1	Safety instructions	38
4.2	Grounding	38
4.3	Virtual reference for IFC 300 (C, W and F version)	39
4.4	Connection diagrams	39

1.1 Sanitary and hygienic solution

The **OPTIFLUX 6000** electromagnetic flow sensor is specifically designed to stay clean and sterile in compliance with the most stringent demands prevailing in the food & beverages and pharmaceutical industries. There are no crevices, gaps or blind spots and the flow sensor offers full CIP/SIP possibilities. The flow sensor is conform FDA food contact material requirements, for all wetted materials and is certified in accordance with EHEDG and 3A.

The flowmeter provides easy installation and commissioning and is available with the flow converter separate, or mounted directly on the flow sensor. Therefore it can be installed in places difficult to access due to for example high temperatures or vibrations. The converter is also available in a stainless steel housing for applications when for example regular cleaning procedures with aggressive cleaning agents, may attack a standard polyurethane coating.

In addition to weld-end connections, this KROHNE flow meter offers a large number of other hygienic connections, including DIN 11851, DIN 11864, clamp and SMS.

Because of its high accuracy, a precise measurement of the medium is possible enabling an accurate measurement of flows whether it is required for blending, dosing or batching. Furthermore its accuracy is maintained even in case of pulsating flows. When a medium has a low conductivity for example in case of glucose or fruit concentrates, the device continues to deliver an optimal performance.

Due to its reinforced liner the OPTIFLUX 6000 is an optimal solution for applications where high temperatures or vacuum impacts can occur. The certified hygienic construction is also available for larger diameters up to DN150, as volumes are increasing and larger pipe sizes are needed with fast increase in the industrial production of beer, wine, milk and other beverages.



Highlights

- Robust stainless steel housing for hygienic and aseptic operation
- PFA liner reinforced with embedded stainless steel grid for vacuum resistance
- High form stability for good accuracy even with high pressures
- Unique L-shaped gasket extends lifetime by preventing protrusion into measurement tube
- Wide choice of the electrode materials, even for extreme chemical applications.
- Simple and effective CIP / SIP
- Typical food and beverages and pharmaceutical process connections and insertion lengths
- Large diameter range DN2.5 up to DN150, to suit any F&B application
- All wetted materials are conform EC 1935/2004 and FDA food contact material regulation.
- Optimal hygienic performance conforming to EHEDG and 3A certification.
- Able to measure at low conductivity $\geq 1 \mu\text{S}/\text{cm}$ (for demin water $\geq 20 \mu\text{S}/\text{cm}$)
- Wide process temperature range $-40\dots140^\circ\text{C}$ / $-40\dots+284^\circ\text{F}$
- PMO certified

Industries

- Food & Beverages
- Pharmaceutical
- Cosmetics

Applications

- Exact blending, dosing and batching
- Beverages including soft drinks, beer, wine and fruits juices
- Milk and other dairy products
- Beverages containing solids (for example yoghurt containing cereals)
- Drugs, caustic sodas, acids, proteins, antibiotics
- CIP media including acids and caustic solutions
- For large-scale production plants with diameter up to DN150

1.2 Options



Reinforced PFA liner

The OPTIFLUX 6000 has an FDA conform PFA liner with an integrated stainless steel reinforcement that ensures vacuum resistance and long-term dimensional stability. The reinforced PFA liner makes sure that the flowmeter keeps its form stability even at high temperatures and very low pressure or vacuum. Therefore the OPTIFLUX 6000 remains its accuracy over time.

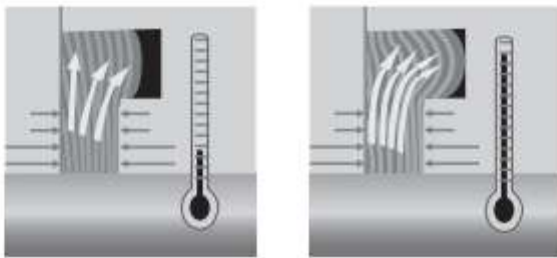

Unique gasket adapter concept

A special sealing concept for stainless steel adapters has been designed with support of TNO, a member of the European EHEDG organization. The sealing concept provides for a smooth and dimensionally stable measuring section between the two process connections. It prevents the gasket from expanding into the measuring tube because during CIP / SIP cleaning procedures, the gasket expands into an expansion chamber. This leads to a sharp sealing at the edge of the pipeline and a perfect transition into the measuring section. In addition, the gasket experiences less stress which results in a longer life time and reduced maintenance.

**Hygienic Converter housing**

The sensor can be complemented with an IFC 100 converter housing made of stainless steel 1.4404. This stainless steel converter housing for the Food and Beverage Industry is specially designed to ensure easy cleanability and resistance to regular rinsing with detergents

A mounting angle of 10 degrees avoids pooling and the special EPDM sealing all around, minimises crevices. Furthermore, the display is made entirely of polymer and can be used in "no glass" designated zones.

1.3 Measuring principle

An electrically conductive fluid flows inside an electrically insulated pipe through a magnetic field. This magnetic field is generated by a current, flowing through a pair of field coils.

Inside of the fluid, a voltage U is generated:

$$U = v \cdot k \cdot B \cdot D$$

in which:

v = mean flow velocity

k = factor correcting for geometry

B = magnetic field strength

D = inner diameter of flowmeter

The signal voltage U is picked off by electrodes and is proportional to the mean flow velocity v and thus the flow rate Q . A signal converter is used to amplify the signal voltage, filter it and convert it into signals for totalizing, recording and output processing.

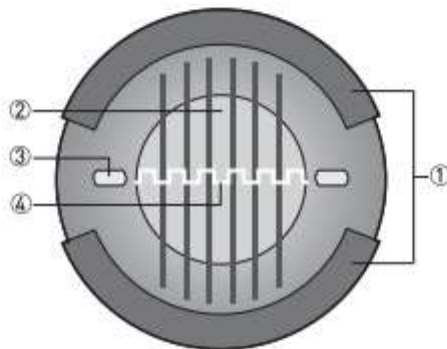

Figure 1-1: Measuring principle

- ① Field coils
- ② Magnetic field
- ③ Electrodes
- ④ Induced voltage [proportional to flow velocity]

2.1 Technical data

- The following data is provided for general applications. If you require data that is more relevant to your specific application, please contact us or your local sales office.
- Additional information (certificates, special tools, software,...) and complete product documentation can be downloaded free of charge from the website (Downloadcenter).

Measuring system

Measuring principle	Faraday's law of induction
Application range	Electrically conductive fluids
Measured value	
Primary measured value	Flow velocity
Secondary measured value	Volume flow

Design

Features	Hygienic design
	Stainless steel housing
	Food & beverage and pharmaceutical process connections
Modular construction	The measurement system consists of a flow sensor and a signal converter. It is available as compact and as separate version.
Compact version	With IFC 050 signal converter: OPTIFLUX 6050 C
	With IFC 100 signal converter: OPTIFLUX 6100 C
	With IFC 300 signal converter: OPTIFLUX 6300 C
Remote version	In wall (W) mount version with IFC 050 signal converter: OPTIFLUX 6050 W
	In wall (W) mount version with IFC 100 signal converter: OPTIFLUX 6100 W
	In field (F), wall (W) or rack (R) mount version with IFC 300 signal converter: OPTIFLUX 6300 F, W or R
Nominal diameter	DN2.5...150 / 1/10" ...6"
Measuring range	-12...+12 m/s / -40...+40 ft/s

Measuring accuracy

Reference conditions	Flow conditions similar to EN 29104
	Medium: Water
	Temperature: +10...+30°C / +50...+86°F
	Operating pressure: 1 bar / 14.5 psig
	Inlet section: ≥ 5 DN
	Electrical conductivity: $\geq 300 \mu\text{S/cm}$
	Wet calibrated on EN 17025 accredited calibration rig by direct volume comparison.
Accuracy curves	Related to volume flow (MV = Measured Value)
	These values are related to the pulse / frequency output.
	The additional typical measuring deviation for the current output is $\pm 10 \mu\text{A}$.
	For detailed information refer to <i>Measuring accuracy</i> on page 26.
Repeatability	$\pm 0.1\%$ of MV, minimum 1 mm/s
Long term stability	$\pm 0.1\%$ of MV

Special calibration	On request
---------------------	------------

Operating conditions

Temperature	
Process temperature	Separate flow sensor: -40...+140°C / -40...+284°F
	Compact with IFC 300 converter: -40...+140°C / -40...+284°F
	Compact with IFC 050 - IFC 100 converter: -40...+120°C / -40...+248°F
	For detailed information refer to <i>Temperatures</i> on page 37. For Ex versions different temperatures are valid. Please check the relevant Ex documentation for details.
Ambient temperature	-40...+65°C / -40...+149°F
Storage temperature	-50...+70°C / -58...+158°F
Pressure	
Ambient pressure	Atmospheric
Nominal flange pressure	For detailed information refer to <i>Dimensions and weights</i> on page 12.
Vacuum load	0 mbar / 0 psi
Chemical properties	
Physical condition	Electrical Conductive liquids
Electrical conductivity	Standard: $\geq 1 \mu\text{S/cm}$
	Water: $\geq 20 \mu\text{S/cm}$
Permissible gas content (volume)	IFC 050: $\leq 3\%$
	IFC 100: $\leq 3\%$
	IFC 300: $\leq 5\%$
Permissible solid content (volume)	IFC 050: $\leq 10\%$
	IFC 100: $\leq 10\%$
	IFC 300: $\leq 70\%$

Installation conditions

Installation	Assure that the flow sensor is always fully filled.
	For detailed information refer to <i>Installation</i> on page 28.
Flow direction	Forward and reverse
	Arrow on flow sensor indicates positive flow direction.
Inlet run	$\geq 5 \text{ DN}$
Outlet run	$\geq 2 \text{ DN}$
Dimensions and weights	For detailed information refer to <i>Dimensions and weights</i> on page 12.

Materials

Sensor housing	DN2.5...15: Stainless steel Duplex (1.4462)
	DN25...150: Stainless steel AISI 304 (1.4301)
Measuring tube	Stainless steel AISI 304 (1.4301)
Adapters	Stainless steel AISI 316 L (1.4404)
	Other materials on request.
Liner	PFA
Connection box (F-version only)	Standard: Aluminum, Polyurethane coated
	Option: Stainless steel AISI (1.4408)
Electrodes	Standard: Hastelloy® C
	Option: Hastelloy® B2, platinum, stainless steel, tantalum, titanium
Gaskets	Standard: EPDM
	FDA recommends EPDM gaskets only if medium ≤ 8% fat.
	Option: Silicone (non-Ex only)

Process connections

DIN 11850 row 2 / 11866 row A	DN2.5...150
DIN 11851	DN2.5...150
DIN 11864-2A flange with notch	DN25...150
DIN 32676	DN25...150
ISO 2037	DN2.5...150
ISO 2852	DN2.5...150
SMS 1145	DN2.5...100
Tri Clamp	1/10" ...6"
Note: sensor diameters < DN10 have DN10 connections, which means the sensor diameter is smaller.	

Electrical connections

Signal cable	
Type A (DS)	Standard cable, double shielded. Max. length: 600 m / 1950 ft (dep. on electrical conductivity and measuring sensor). See documentation of the converter for more information.
Type B (BTS)	Optional cable, triple shielded. Max. length: 600 m / 1950 ft (dep. on electrical conductivity and measuring sensor). See documentation of the converter for more information.

Approvals and certificates

CE	
This device fulfills the statutory requirements of the EU directives. The manufacturer certifies successful testing of the product by applying the CE mark.	
	For full information of the EU directives and standards and the approved certifications, please refer to the CE declaration or the website of the manufacturer.
Hazardous areas	
ATEX	Please check the relevant Ex documentation for details.
	Compact version with IFC 300 C converter:
	II 2 G, II D, II 2 (1) G
	Remote (F) version:
	II 2 G, II 2 D
FM	In combination with IFC 300 C or F converter:
	Class I, Div. 2, Groups A, B, C and D
	Class II, Div. 2, Groups F and G
	Class III, Div. 2, Groups F and G
	Only available for DN2.5...15
CSA	In combination with IFC 300 C or F converter:
	Class I, Div. 2, Groups A, B, C and D
	Class II, Div. 2, Groups F and G
	Class III, Div. 2, Groups F and G
	Only available for DN2.5...15
Other approvals and standards	
Protection category acc. to IEC 529/ EN 60529	Standard
	IP 66/67 (NEMA 4/4X/6)
	Option (F version only)
	IP 68 field (NEMA 6P)
	IP 68 factory (NEMA 6P)
	IP 68 is only available for separate design and with a stainless steel connection box.
	Option IP69
IP 67/69 is available for connection box and IFC 100 in stainless steel.	
Hygienic	3A approved
	EHEDG
Shock test	IEC 68-2-27
	30 g for 18 ms
Vibration test	IEC 68-2-64
	f = 20 - 2000 Hz, rms = 4,5 g, t = 30 min.

2.2 Dimensions and weights

DIN 11850 (row 2 or DIN 11866 row A)

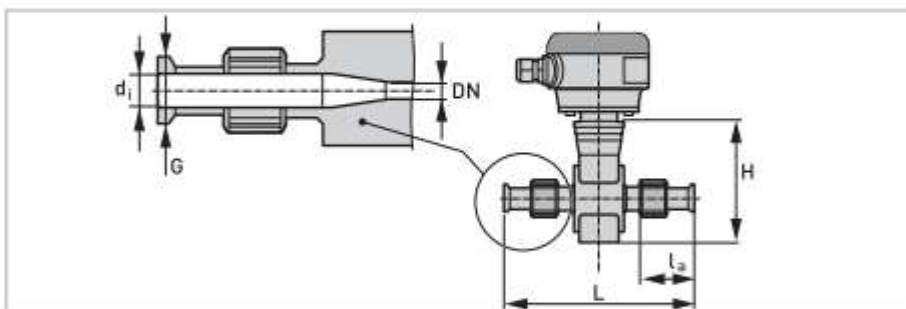

DN2.5...10 screwed adapter with DN10 process connections / DN15 screwed adapter.

Nominal size		Dimensions [mm]						Approx. weight
		Adapter			Flowmeter			
DN	PN	d_i	G	l_a	L	H	W	[kg]
2.5...10	40	10	13	32	180	120	44	1.5
15	40	16	19	32	180	120	44	1.5

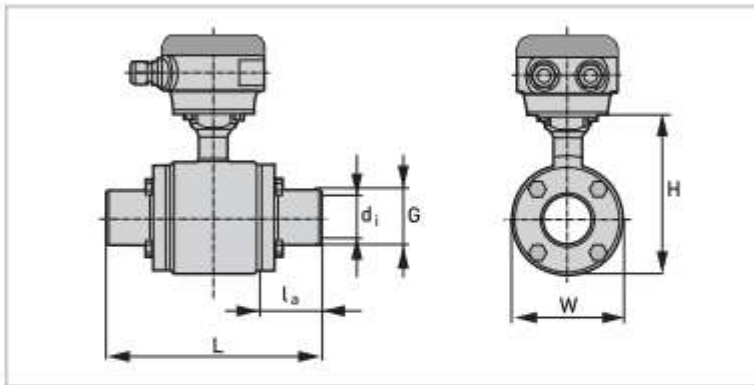

DN25...150 bolted adapter

Nominal size		Dimensions [mm]						Approx. weight
		Adapter			Flowmeter			
DN	PN	d_i	G	l_a	L	H	W	[kg]
25	40	26	29	20.6	132.6	128	89	3
40	40	38	41	61.3	220	153	114	5.3
50	25	50	53	61.3	220	153	114	6.8
65	25	66	70	41.8	220	180	141	10.9
80	25	81	85	66.8	280	191	152	11.2
100	16	100	104	59.3	280	242	203	18.4
125	10	125	129	66.3	319	258	219	29.5
150	10	150	154	64.3	325	293	254	44.3

DIN 11851

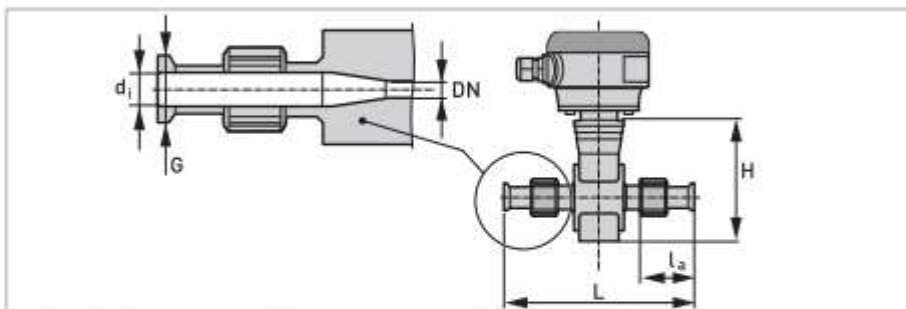

DN2.5...10 screwed adapter with DN10 process connections / DN15 screwed adapter

Nominal size		Dimensions [mm]						Approx. weight
		Adapter		Flowmeter				
DN	PN	d_i	G	l_a	L	H	W	[kg]
2.5...10	40	10	Rd 28 x 1/8"	53.1	214	142	44	1.5
15	40	16	Rd 34 x 1/8"	53.1	214	142	44	1.5

DIN 11851

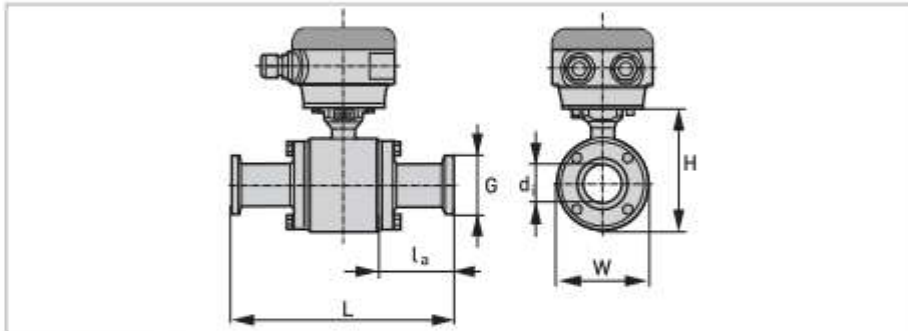

DN25...150 bolted adapter

Nominal size		Dimensions [mm]						Approx. weight [kg]
		Adapter			Flowmeter			
DN	PN	d_i	G	l_a	L	H	W	
25	40	26	Rd 52 x 1/6"	49.3	190	128	89	3.2
40	40	38	Rd 65 x 1/6"	91.3	280	153	114	5.5
50	25	50	Rd 78 x 1/6"	93.3	284	153	114	5.3
65	25	66	Rd 95 x 1/6"	77.8	292	180	141	10
80	25	81	Rd 110 x 1/4"	107.8	362	191	152	12.5
100	16	100	Rd 130 x 1/4"	109.3	380	242	203	21.8
125	10	On request						
150	10	On request						

DIN 11864-2A

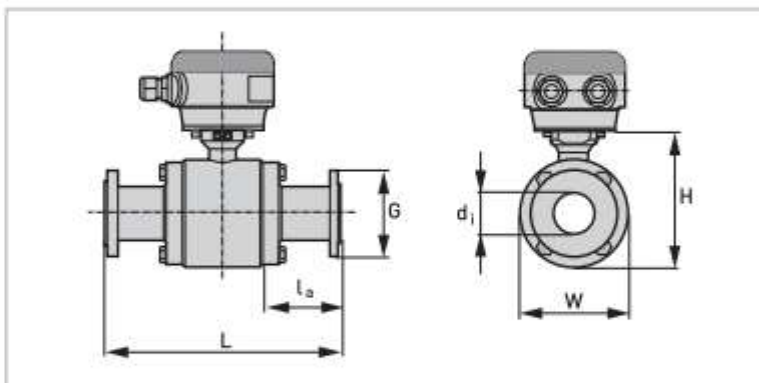

DN25...150 bolted adapter

Nominal size		Dimensions [mm]						Approx. weight [kg]
		Adapter			Flowmeter			
DN	PN	d _i	G	l _a	L	H	W	
25	40	26	70	45.8	183	128	89	4.4
40	25	38	82	83.3	264	153	114	7.5
50	25	50	94	83.3	264	153	114	9
65	25	66	113	63.8	264	180	141	14.5
80	25	81	133	122.8	392	191	152	18.6
100	16	100	159	115.3	392	242	203	28.2
125	10	125	183	121	429	259	219	35
150	10	150	213	127	450	294	254	52

DIN 32676

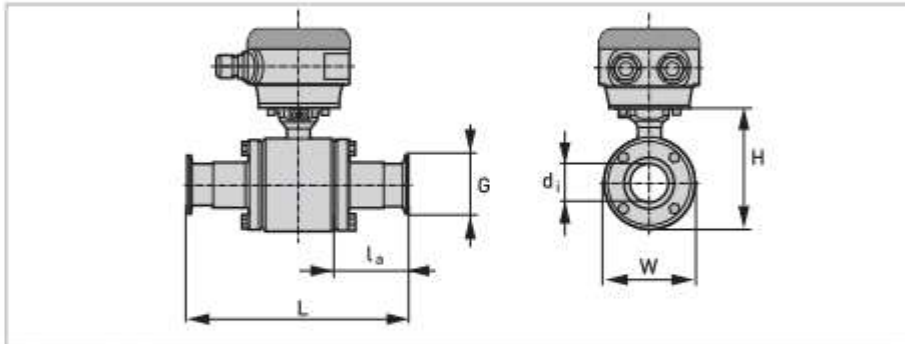

DN25...150 bolted adapter

Nominal size		Dimensions [mm]						Approx. weight [kg]
		Adapter			Flowmeter			
DN	PN	d_i	G	l_a	L	H	W	
25	16	26	50.5	41.8	175	128	89	3.2
40	16	38	50.5	80.8	259	153	114	5.5
50	16	50	64	80.8	259	153	114	5.3
65	16	66	91	67.8	272	180	141	10
80	16	81	106	92.8	332	191	152	12.5
100	16	100	119	85.3	332	242	203	21.8
125	16	125	155	90	366	259	219	30
150	16	150	213	127	450	294	254	45

ISO 2037

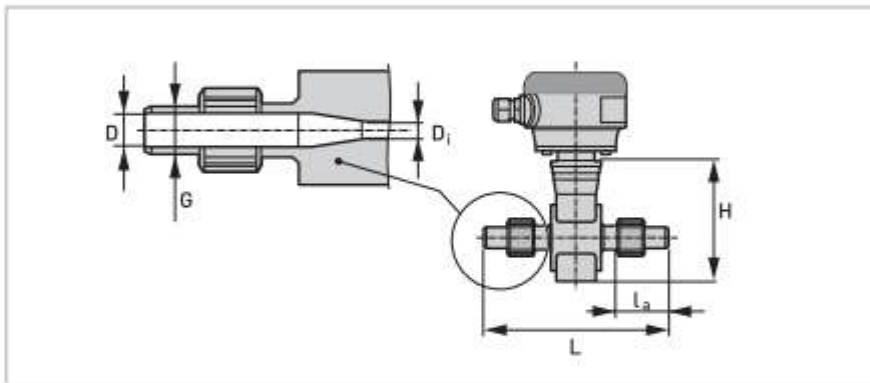

DN2.5...10 screwed adapter with DN10 process connections / DN17.2 screwed adapter

Nominal size		Dimensions [mm]						Approx. weights [kg]
		Adapter			Flowmeter			
DN	PN	d_i	G	l_a	L	H	W	
2.5...12	40	10	15	32	180	142	44	1.5
17.2	40	16	21	32	180	142	44	1.5

ISO 2037

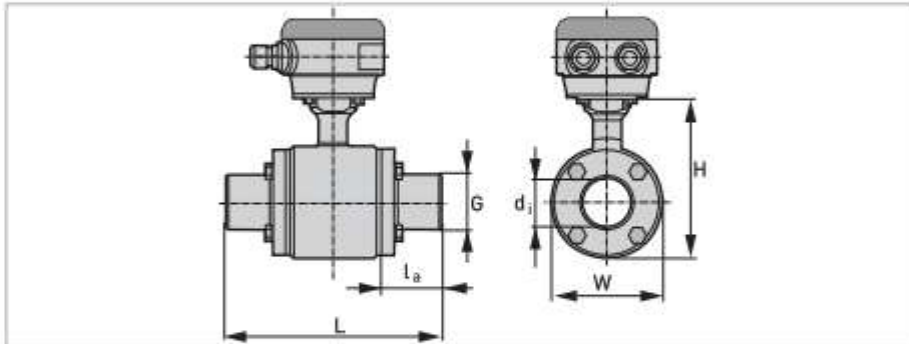

DN25...150 bolted adapter

Nominal size		Dimensions [mm]						Approx. weights
		Adapter			Flowmeter			
DN	PN	d_i	G	l_a	L	H	W	[kg]
25	40	22.6	31	20.6	132.6	128	89	3
38	40	38	43	61.3	220	153	114	5.3
51	25	49	55	61.3	220	153	114	5
63.5	25	60.3	71	41.8	220	180	141	9
76.1	25	72.9	86	66.8	280	191	152	10.8
101.6	16	97.6	105	59.3	280	242	203	18.4
114.3	10	110.3	130	66.3	319	258	219	29.5
139.7	10	135.7	156	64.3	325	293	254	44.3

ISO 2852

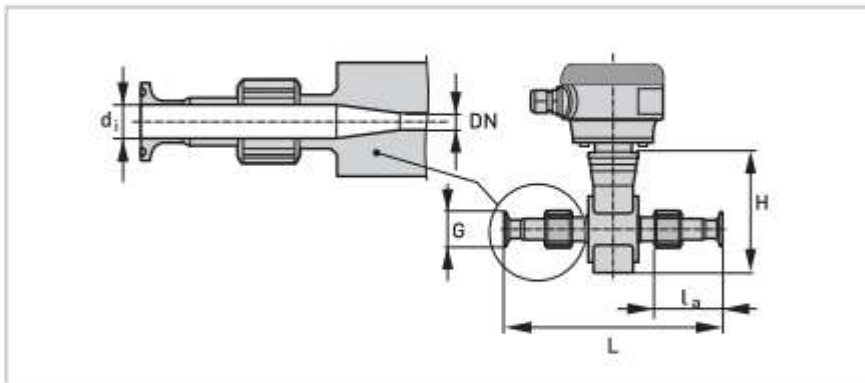

DN2.5...10 screwed adapter with DN10 process connections / DN17.2 screwed adapter

Nominal size			Dimensions [mm]						Approx. weight [kg]
			Adapter			Flowmeter			
DN	[Inch]	PN	d_i	G	L_a	L	H	W	
2.5...10	1/10"...3/8"	16	10	34	51.6	219	142	44	1.8
17.2	1/2"	16	16	34	51.6	219	142	44	1.8

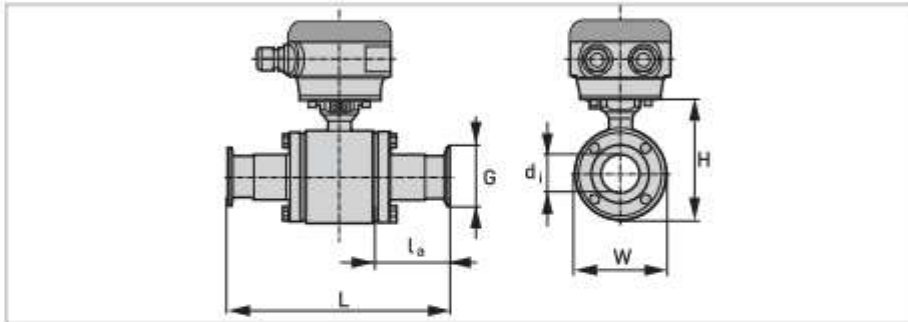

DN25...150 bolted adapter

Nominal size			Dimensions [mm]						Approx. weight [kg]
			Adapter			Flowmeter			
DN	[Inch]	PN	d_i	G	l_a	L	H	W	
25	1"	16	22.6	50,5	41.8	175	128	89	3.3
38	1.5"	16	35.6	50,5	87.8	273	153	114	5.4
50	2"	16	48.6	64	87.8	273	153	114	5.2
63.5	2.5"	10	60.3	77.5	68.3	273	180	141	9.5
76.1	3"	10	72.9	91	93.3	333	191	152	11.2
101.6	4"	8	97.6	119	85.8	333	242	203	19.1
114.3	5"	5	110.3	211	90	366	259	219	30
139.7	6"	5	135.7	246	90	376	294	254	45

Tri Clamp

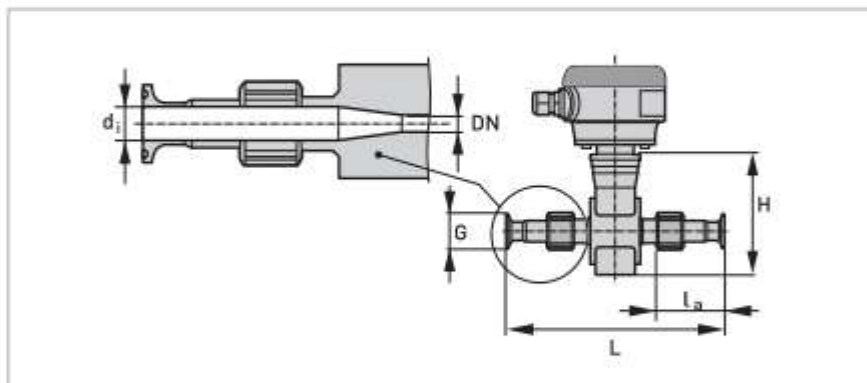

DN1/10...1/2" screwed adapter

Nominal size		Dimensions [inch]						Approx. weight [kg]
		Adapter			Flowmeter			
DN	PN	d_i	G	l_a	L	H	W	
1/10"...3/8"	20	0.37	0.98	1.97	8.5	5.59	1.73	1.5
1/2"	20	0.62	0.98	1.97	8.5	5.59	1.73	1.5

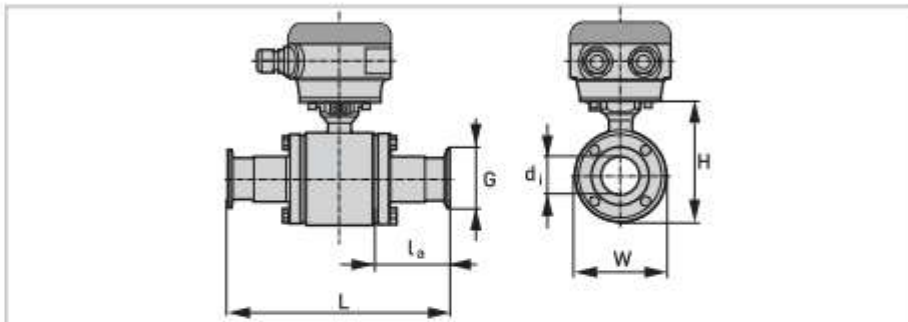

DN1...6" bolted adapter

Nominal size		Dimensions [inch]						Approx. weight
		Adapter			Flowmeter			
DN	PN	d_i	G	l_a	L	H	W	[kg]
1"	20	0.85	1.98	1.02	5.64	5.04	3.5	3.2
1½"	20	1.35	1.98	3.46	10.75	6.02	4.49	5.5
2"	20	1.85	2.52	3.46	10.75	6.02	4.49	5.3
2½"	20	2.35	3.05	2.69	11.5	7.09	5.55	10
3"	20	2.85	3.54	3.68	14.25	7.52	5.98	12.5
4"	12	3.83	4.68	3.38	14.96	9.53	7.99	21.8
5"	'-	4.78	5.69	3.54	14.43	10.20	8.62	30
6"	'-	5.78	6.57	3.62	14.98	11.57	10.00	45

SMS 1145 Adapter

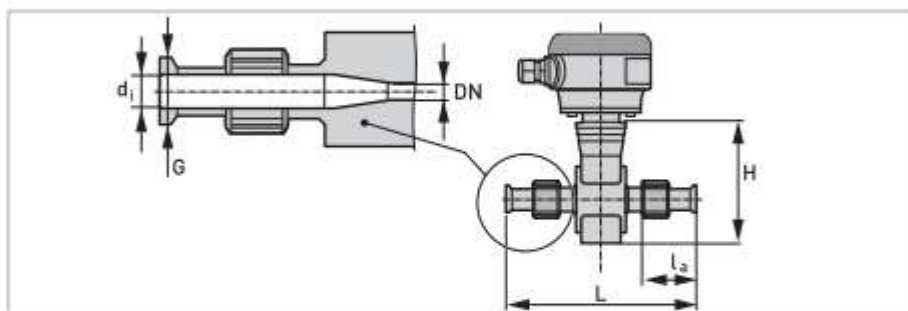

DN2.5...10 screwed adapter with DN10 process connections / DN15 screwed adapter

Nominal size		Dimensions [mm]						Approx. weight [kg]
		Adapter			Flowmeter			
DN	PN	d _i	G	l _a	L	H	W	
2.5	39	10	Rd 40-6	53	226	128	44	2
4	39	10	Rd 40-6	53	226	128	44	2
6	39	10	Rd 40-6	53	226	128	44	2
10	6	10	Rd 40-6	53	226	128	44	2
15	6	10	Rd 40-6	53	226	128	44	2

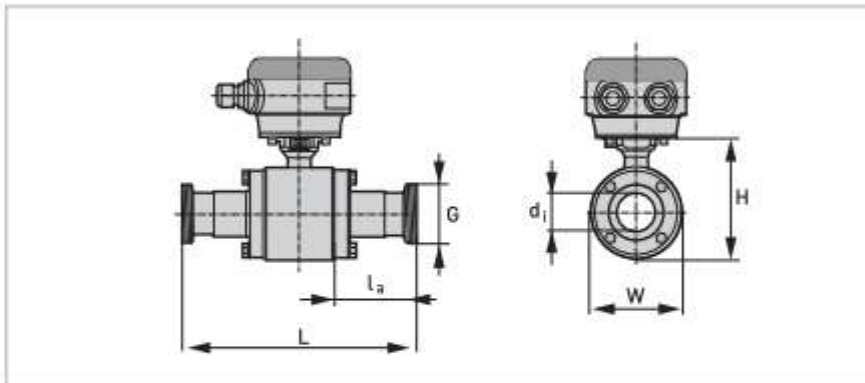

DN25...100 bolted adapter

Nominal size		Dimensions [mm]						Approx. weight
		Adapter			Flowmeter			
DN	PN	d_i	G	l_a	L	H	W	[kg]
25	6	22.6	Rd 40-6	28.1	147.6	128	89	3.2
38	6	35.5	Rd 60-6	54	262	153	114	5.7
51	6	48.6	Rd 70-6	84.3	266	153	114	5.4
63.5	6	60.3	Rd 85-6	69.8	276	180	141	9.9
76	6	72.9	Rd 98-6	99.8	346	191	152	12.1
100	6	97.6	Rd 132-6	44	336	242	203	21.9

2.3 Measuring accuracy

Every electromagnetic flowmeter is calibrated by direct volume comparison. The wet calibration validates the performance of the flowmeter under reference conditions against accuracy limits.

The accuracy limits of electromagnetic flowmeters are typically the result of the combined effect of linearity, zero point stability and calibration uncertainty.

Reference conditions

- Medium: water
- Temperature: +5...35°C / +41...95°F
- Operating pressure: 0.1...5 barg / 1.5...72.5 psig
- Inlet section: ≥ 5 DN
- Outlet section: ≥ 2 DN

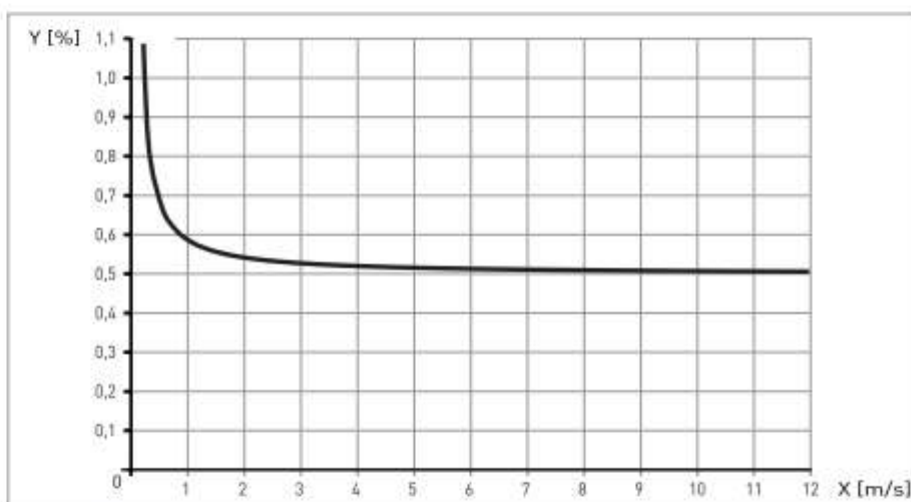

Figure 2-1: Flow velocity vs. accuracy

X [m/s]: flow velocity

Y [%]: deviation from the actual measured value (mv)

Compact with IFC 050	Accuracy	Curve
DN10...150 / 3/8...6"	0.5% of MV + 1 mm/s	

Optionally for IFC 050; extended calibration at 2 points for optimised accuracy.

For more details on optimised accuracy, see the concerning signal converter documentation.

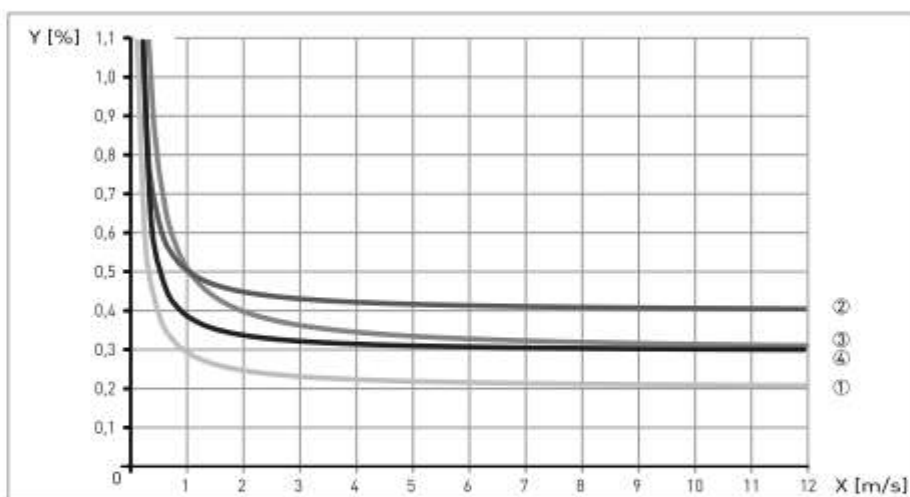

Figure 2-2: Flow velocity vs. accuracy

X [m/s] : flow velocity

Y [%]: deviation from the actual measured value (mv)

Compact with IFC 300	Accuracy	Curve
DN2.5...6 / 1/10...1/4"	0.3% of MV + 2 mm/s	③
DN10...150 / 3/8...6"	0.2% of MV + 1 mm/s	①

Compact with IFC 100	Accuracy	Curve
DN2.5...6 / 1/10...1/4"	0.4% of MV + 1 mm/s	②
DN10...150 / 3/8...6"	0.3% of MV + 1 mm/s	④

Optionally for IFC 100; extended calibration at 2 points for optimised accuracy.

For more details on optimised accuracy, see the concerning signal converter documentation.

3.1 Intended use

The measurement of volumetric flowrate of electrically conductive fluids in hygienic applications.

3.2 General notes on installation

Inspect the packaging carefully for damages or signs of rough handling. Report damage to the carrier and to the local office of the manufacturer.

Do a check of the packing list to make sure that you have all the elements given in the order.

Look at the device nameplate to ensure that the device is delivered according to your order. Check for the correct supply voltage printed on the nameplate.

3.2.1 Vibration

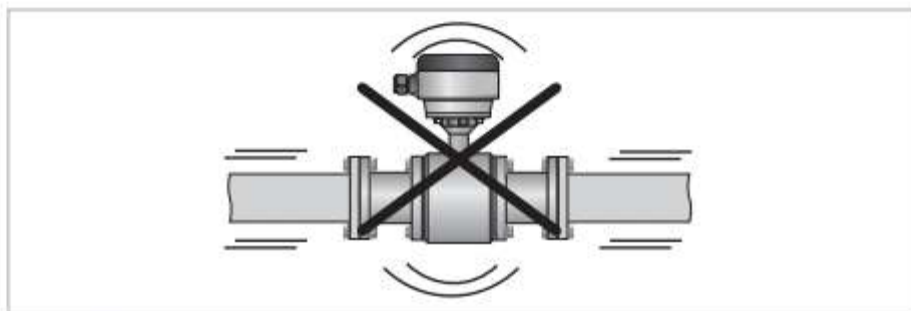

Figure 3-1: Avoid vibrations

3.2.2 Magnetic field

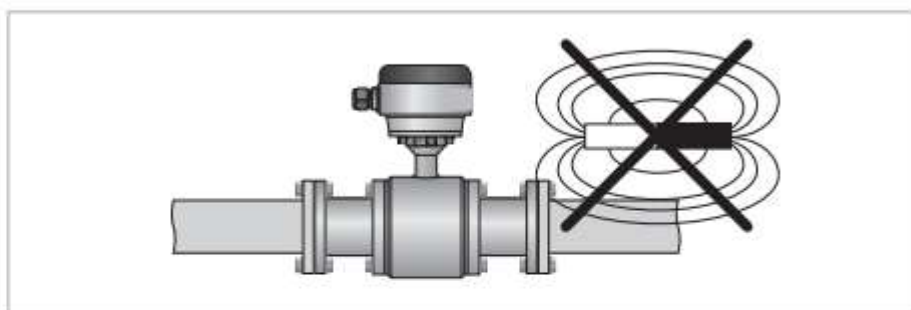

Figure 3-2: Avoid magnetic fields

3.3 Installation conditions

3.3.1 Inlet and outlet

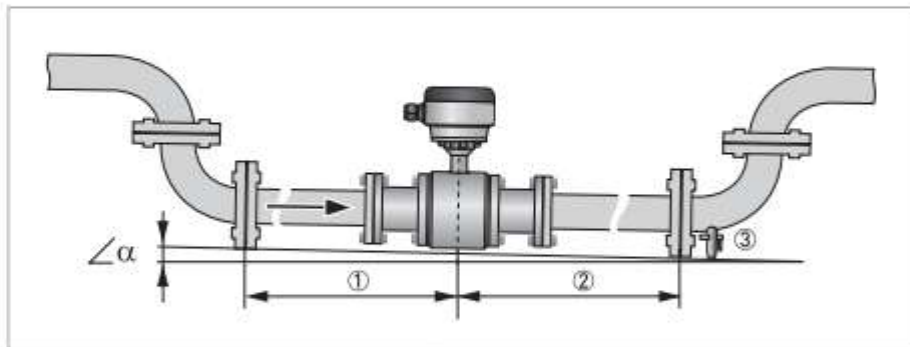

Figure 3-3: Recommended inlet and outlet

- ① Refer to chapter "Bends in 2 or 3 dimensions"
- ② ≥ 2 DN
- ③ Drain valve [to empty pipeline]
- $\angle \alpha ; > 2^\circ$

3.3.2 Bends in 2 or 3 dimensions

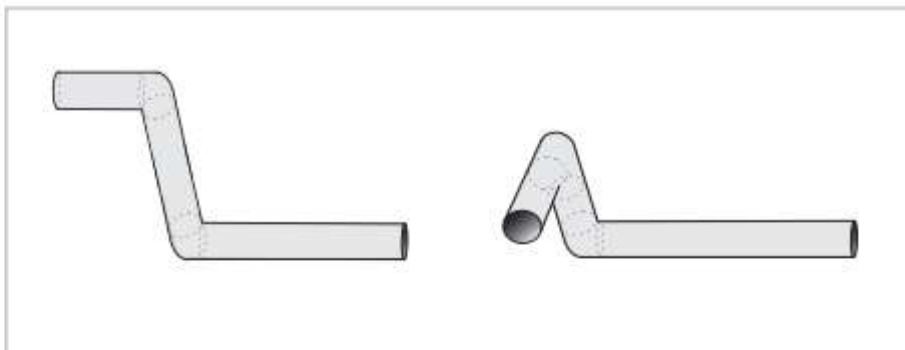

Figure 3-4: Inlet when using 2 and/or 3 dimensional bends upstream of the flowmeter

Inlet length: using bends in 2 dimensions: ≥ 5 DN; when having bends in 3 dimensions: ≥ 10 DN

*2 Dimensional bends occur in a vertical plane only, while 3 Dimensional bends occur in both vertical **and** horizontal plane.*

3.3.3 T-section

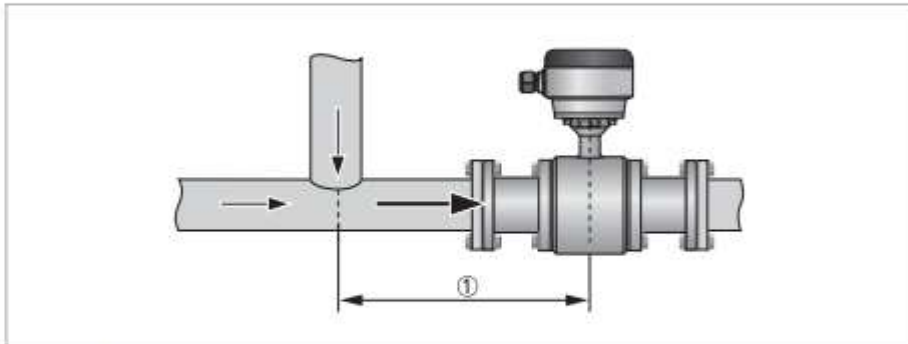

Figure 3-5: Distance behind a T-section

① $\geq 10 \text{ DN}$

3.3.4 Bends

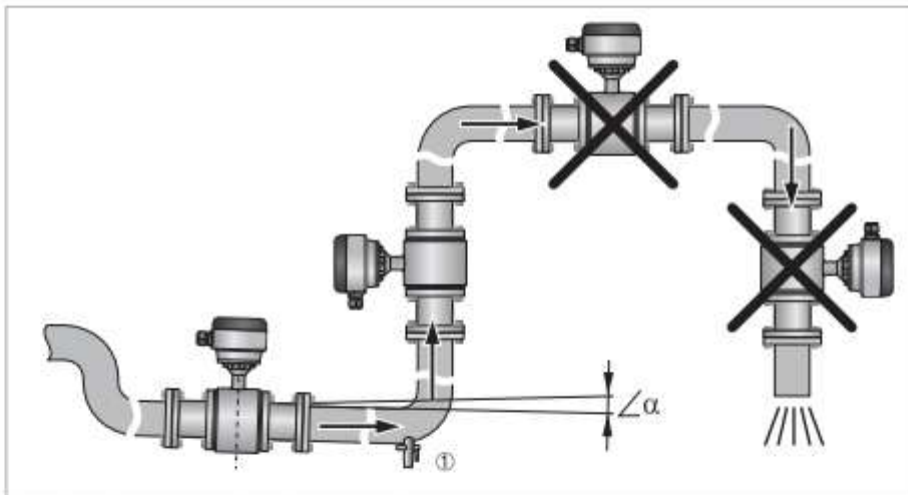

Figure 3-6: Installation in bending pipes

$\angle \alpha ; > 2^\circ$

① Drain valve (to empty pipeline)

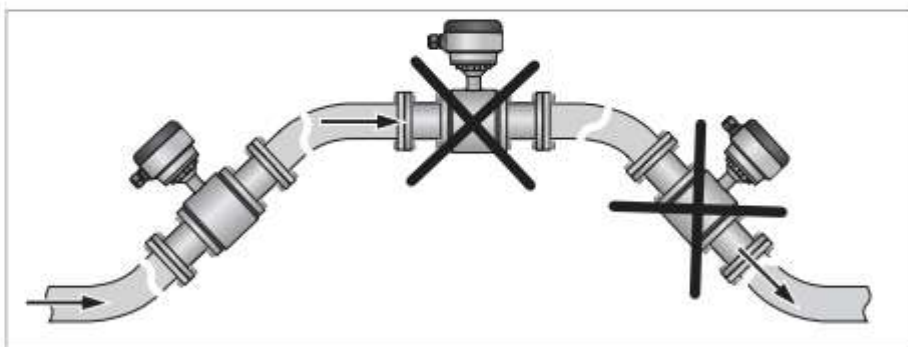

Figure 3-7: Installation in bending pipes

3.3.5 Open discharge

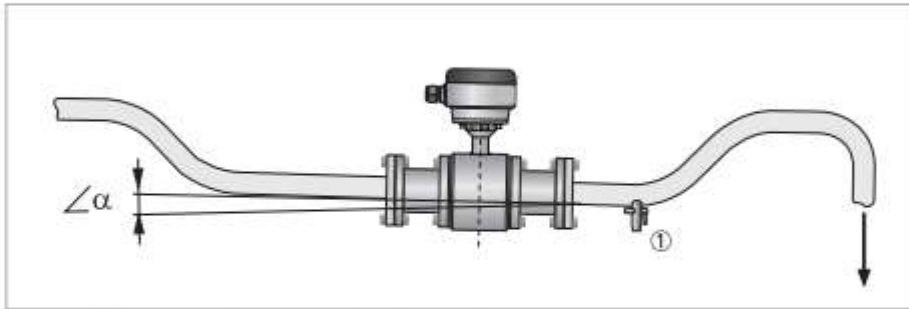

Figure 3-8: Installation in front of an open discharge

$\angle\alpha ; >2^\circ$

① Drain valve (to empty pipeline)

3.3.6 Control valve

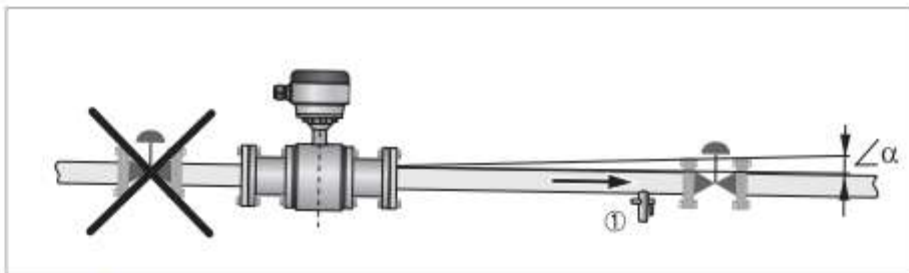

Figure 3-9: Installation in front of a control valve

$\angle\alpha ; >2^\circ$

① Drain valve (to empty pipeline)

3.3.7 Pump

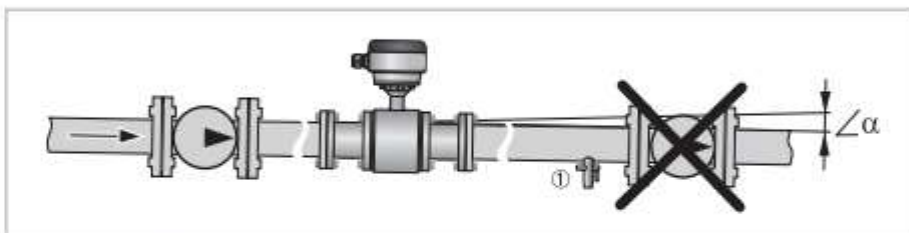

Figure 3-10: Installation behind a pump

3.3.8 Air venting and vacuum forces

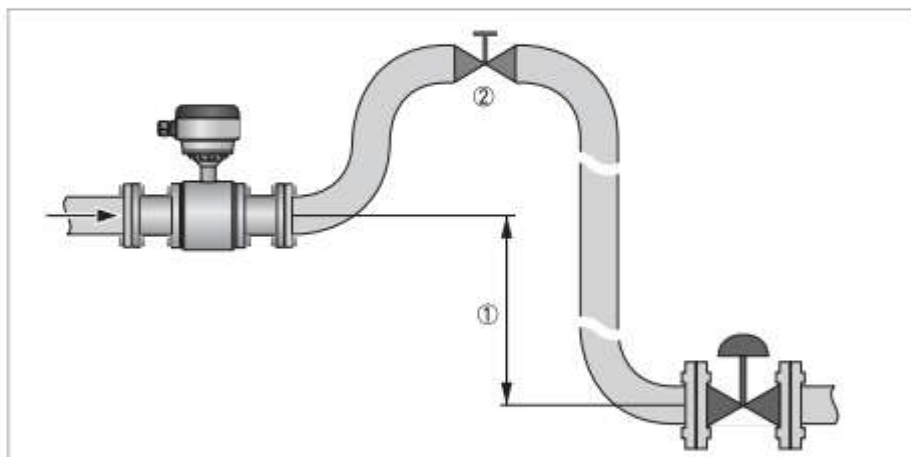

Figure 3-11: Air venting

- ① ≥ 5 m
- ② Air ventilation point

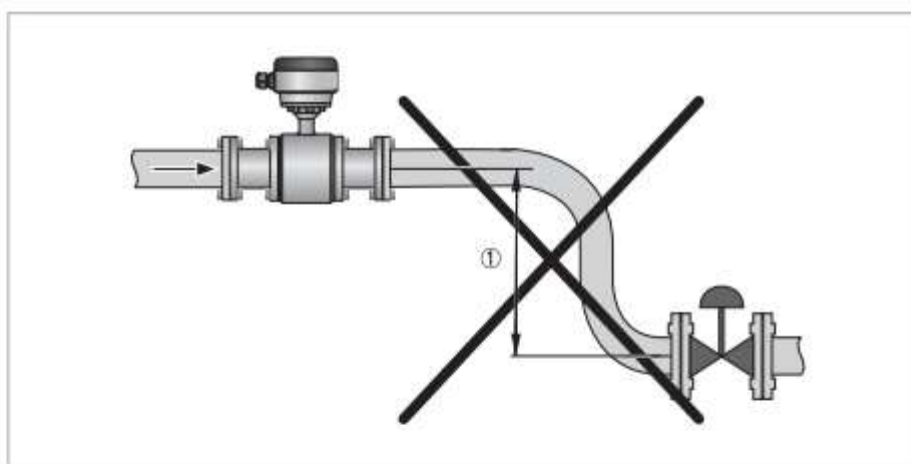

Figure 3-12: Vacuum

- ① ≥ 5 m

3.3.9 Mounting requirements for self-draining

Applicable for 3A marked installations: install flow sensor in vertical pipelines or in pipelines with a minimum slope as indicated!

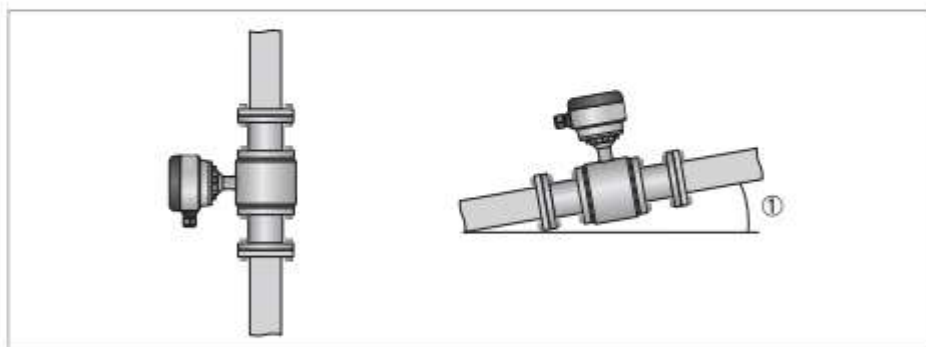

Figure 3-13: Installation note for 3A marked installations

① Minimum slope

Minimum slope

Nominal diameter	DIN 11850	ISO 2037	DIN 11864 2A	ISO 2852	DIN 32676	Tri Clamp
2.5...6	10°	10°	-	-	-	-
10	3°	3°	-	-	-	-
15	10°	10°	-	①	-	-
25	10°	3°	10°	3°	10°	3°
40...50	5°	3°	5°	3°	5°	3°
65...80	10°	3°	10°	3°	10°	3°
100	5°	3°	5°	3°	5°	3°
125...150	10°	3°	10°	3°	①	①

① on request

3.3.10 Flange deviation

Max. permissible deviation of pipe flange faces:
 $L_{max} - L_{min} \leq 0.5 \text{ mm} / 0.02''$

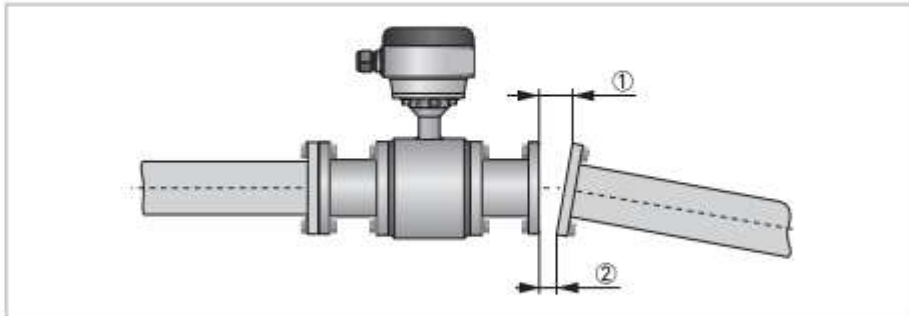

Figure 3-14: Flange deviation

- ① L_{max}
- ② L_{min}

3.3.11 Mounting position

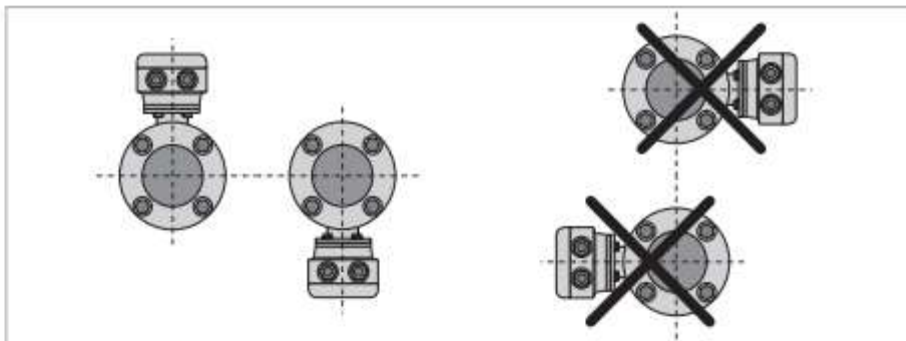

Figure 3-15: Mounting position

- Mount flow sensor either with signal converter aligned upwards or downwards.
- Install flow sensor in line with the pipe axis.
- Pipe flange faces must be parallel to each other.

3.4 Mounting

Please take care to use the proper gasket to prevent damaging the liner of the flowmeter. In general, the use of spiral wound gaskets is not advised, as it could severely damage the liner of the flowmeter.

3.4.1 Torques and pressures

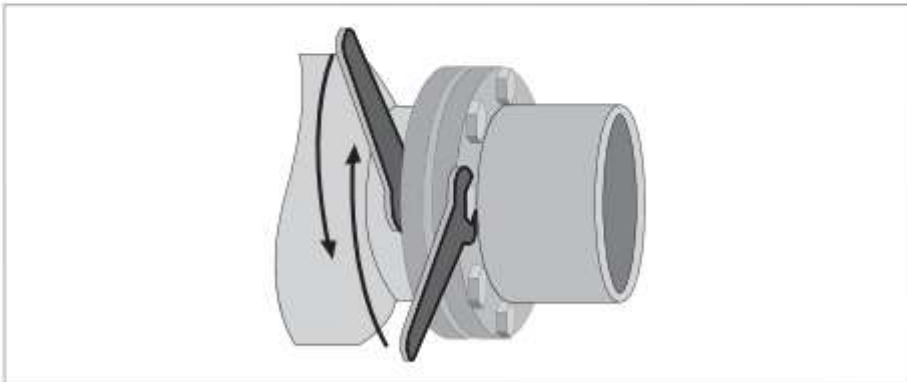

Figure 3-16: Tightening of bolts

The max. allowable torque depends on the gasket material, see datasheet for detailed information.

Bolts to be used from material SS, class 70-A2.

Tightening of bolts

- Always tighten the bolts uniformly and in diagonally opposite sequence.
- Do not exceed the maximum torque value.
- Step 1: Apply approx. 50% of max. torque given in table.
- Step 2: Apply approx. 80% of max. torque given in table.
- Step 3: Apply 100% of max. torque given in table.

Maximum torque for 11864-2A flange version

Nominal diameter [mm]	Pressure rating	Bolts	Max. torque [Nm]
25	PN 40	4x M6	7
40	PN 40	4x M8	16
50	PN 25	4x M8	16
80	PN 25	6x M8	16
100	PN 25	6x M8	16
125	PN 10	6x M10	32
150	PN 10	6x M10	32

Type of connection	Size of connection		Max. operating pressure	
	mm	inch	bar	psig
Aseptic weld on for pipes to DIN 11850	DN10...40	-	40	580
	DN50...80	-	25	360
	DN100	-	25	360
	DN125...150	-	10	145
Aseptic weld on for pipes to ISO 2037	12...38	-	40	580
	51...76.1	-	25	360
	101.6	-	25	360
	114.3...139.7	-	16	230
Dairy screw to DIN 11851 ①	DN10...40	-	40	580
	DN50...80	-	25	360
	DN100	-	25	360
	DN125...150	-	16	230
Screwed to SMS 1145 ①	DN2.5...6	-	6	90
	DN10...100	-	16	230
Flanges to DIN 11864-2A	DN25...40	-	40	580
	DN50...80	-	25	360
	DN100	-	16	230
	DN125...150	-	10	145
Clamp joint to ISO 2852	12...38	-	25	360
	51...76.1	-	16	230
	100...139.7	-	10	145
Clamp joint to DIN 32676	DN10...50	-	25	360
	DN50...80	-	16	230
	DN100...125	-	10	145
Clamp joint to Tri Clamp	-	1/2...1 1/2	25	360
	-	2...3	16	230
	-	4...6	10	145
Vacuum load	all versions and sizes		0 mbar abs.	0 psia

① Without 3A mark

3.4.2 Installation of weld-on versions

For mounting sensors with weld-on connections, please follow the procedure as follows:

- Mount the sensor completely in the pipeline and spot the weld-on connections to the pipe. This is necessary to align the mounting bores of the flange.
- Remove the sensor body and the gaskets from the adapters by loosen the screws.
- Weld the adapters completely to the pipe.
- When the pipe is cold again, reinstall the gasket and mount the sensor.

3.4.3 Temperatures

Protect the device from direct sunlight.

Ambient temperature

	°C		°F	
	min.	max.	min.	max.
Separate flow sensor Compact version with; IFC 050, IFC100 & IFC 300	-40	65	-40	149
Separate flow sensor Compact version with; IFC100 stainless steel	-40	60	-40	140

Maximum process temperature

Type of connection	Separate flow sensor		Compact + IFC 050 & IFC100		Compact + IFC 300	
	°C	°F	°C	°F	°C	°F
Aseptic weld on for pipes to DIN 11850	140	284	120 ①	248 ②	140	284
Aseptic weld on for pipes to ISO 2037	140	284	120 ①	248 ②	140	284
Dairy screw to DIN 11851 ③	140	284	120 ①	248 ②	140	284
Screwed to SMS 1145 ③	140	284	120 ①	248 ②	140	284
Flanges to DIN 11864-2A	140	284	120 ①	248 ②	140	284
Clamp joint to ISO 2852	120	248	120	248	120	248
Clamp joint to DIN 32676	140	284	120 ①	248 ②	140	284
Clamp joint to Tri Clamp	120	248	120	248	120	248

① 140°C if ambient temperature ≤ 40°C

② 284°F if ambient temperature ≤ 104°F

③ Without 3A mark

3.4.4 Cleaning

In principle, no special maintenance is needed. However, make sure that the used cleaning product doesn't affect the outer surface and the gaskets.

4.1 Safety instructions

All work on the electrical connections may only be carried out with the power disconnected. Take note of the voltage data on the nameplate!

Observe the national regulations for electrical installations!

For devices used in hazardous areas, additional safety notes apply; please refer to the Ex documentation.

Observe without fail the local occupational health and safety regulations. Any work done on the electrical components of the measuring device may only be carried out by properly trained specialists.

Look at the device nameplate to ensure that the device is delivered according to your order. Check for the correct supply voltage printed on the nameplate.

4.2 Grounding

The device must be grounded in accordance with regulations in order to protect personnel against electric shocks.

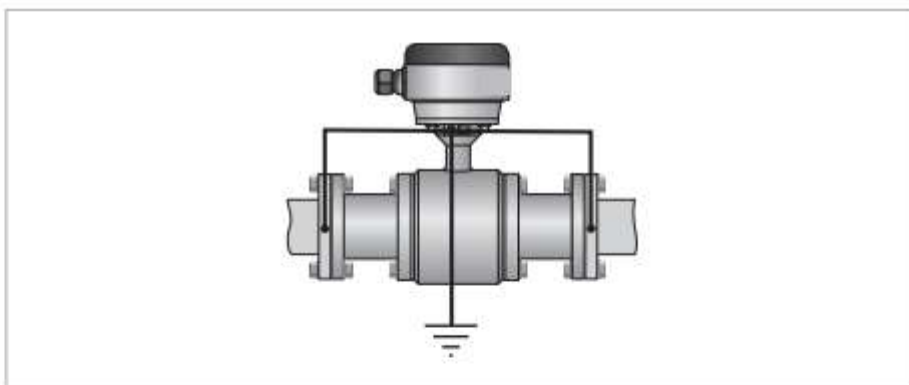

Figure 4-1: Grounding

4.3 Virtual reference for IFC 300 (C, W and F version)

Benefits of virtual reference:

- Grounding rings or grounding electrodes can be omitted.
- Safety increases by reducing the number of potential leakage points.
- The installation of the flowmeters is much easier.

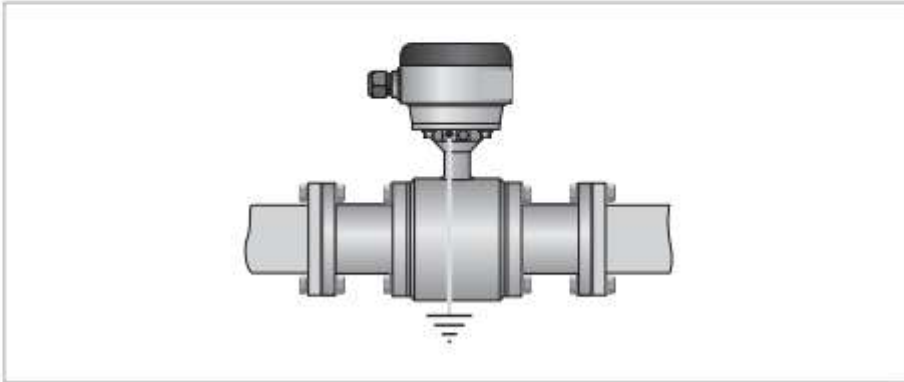

Figure 4-2: Virtual reference

Minimum requirements:

- Size: \geq DN10 / 3/8"
- Electrical conductivity: \geq 200 μ S/cm
- Electrode cable: max. 50 m / 164 ft, type DS

4.4 Connection diagrams

For the connection diagrams please refer to the documentation of the applicable signal converter.



KROHNE – Process instrumentation and measurement solutions

- Flow
- Level
- Temperature
- Pressure
- Process Analysis
- Services

Head Office KROHNE Messtechnik GmbH
Ludwig-Krohne-Str. 5
47058 Duisburg (Germany)
Tel.: +49 203 301 0
Fax: +49 203 301 10389
info@krohne.com

The current list of all KROHNE contacts and addresses can be found at:
www.krohne.com

KROHNE