

Indicating temperature switch

Model : T931 (Case compensation system SAMA class IIIB)

Model : T932 (Full compensation system SAMA class IIIA)

Spec. sheet no. TD09-02

Service intended

This temperature switch is installed with a micro contact and it is suitable for measuring the temperature of corrosive fluid. Dead band is fixed.

Nominal diameter

150 mm

Repeatability

±1.0 % of adjustable range

Accuracy

±2.0 % of full scale

Measuring system

Organic gas : 0 ~ 200 °C (Only T932)

Inert gas : -200 ~ 700 °C

Working range

Maximum scale value



Standard features

Location of stem and mounting

Bottom connection, surface, case mounting

Case

Silver gray finished aluminium

Cover

Silver gray finished aluminium

Window

Instrument glass

Switch type

Micro switch snap action

Switch form

One SPDT for single setpoint

Two SPDT for dual setpoint

Capillary

Capillary : 1.6/0.2 mm, 316SS

Armored tube : 7.5/5.5 mm, 304SS

Contacts

AC 125 V / 250 V, 7 A

AC 125 V / 250 V, 7 A for resistance load

AC 125 V / 250 V, 7 A for inductive load

Conduit connection

½", ¾" PF

Stem

8.0, 10.0 and 12.0 mm

316SS and 316L SS

Stem, process connection

⅜", ½", ¾" PT, NPT and PF

Option

Special accuracy : ±1.0 % of full scale

1. Base model

- T931** Indicating temperature switch
(Case compensation system)
- T932** Indicating temperature switch
(Full compensation system)

2. Switch form

- 1** One SPDT contact for single setpoint
- 2** Two SPDT contact for dual setpoint

3. Type of mounting

- B** Bottom connection, surface, case mounting plate

4. Stem material

- 1** 316SS
- 2** 316L SS

5. Stem, process connection

- A** None
- D** 5/8"
- E** 1/2"
- F** 3/4"

6. Stem connection type (CF: Compression fitting)

- A** None
- E** CF + PT
- F** CF + NPT
- G** CF + PF
- H** MT + PT (Movable thread)
- I** MT + NPT (Movable thread)
- J** MT + PF (Movable thread)

7. Stem outer diameter (mm)

- 2** 8.0
- 3** 10.0
- 4** 12.0
- Z** Other

8. Range

- XXX** Refer to scale range table

9. Capillary length (m)

- A** Direct mounting type
- P** 2
- Q** 3
- S** 5
- V** 8
- X** 10
- Z** Other

10. Accessories

- 0** None
- 1** Thermowell
- 2** Special accuracy (± 1.0 % of full scale)
- 3** Thermowell and special accuracy

1	2	3	4	5	6	7	8	9	10
T931	1	B	1	E	C	3	XXX	P	1

Sample
ordering code

T931, T932 : Type of mounting

Code B

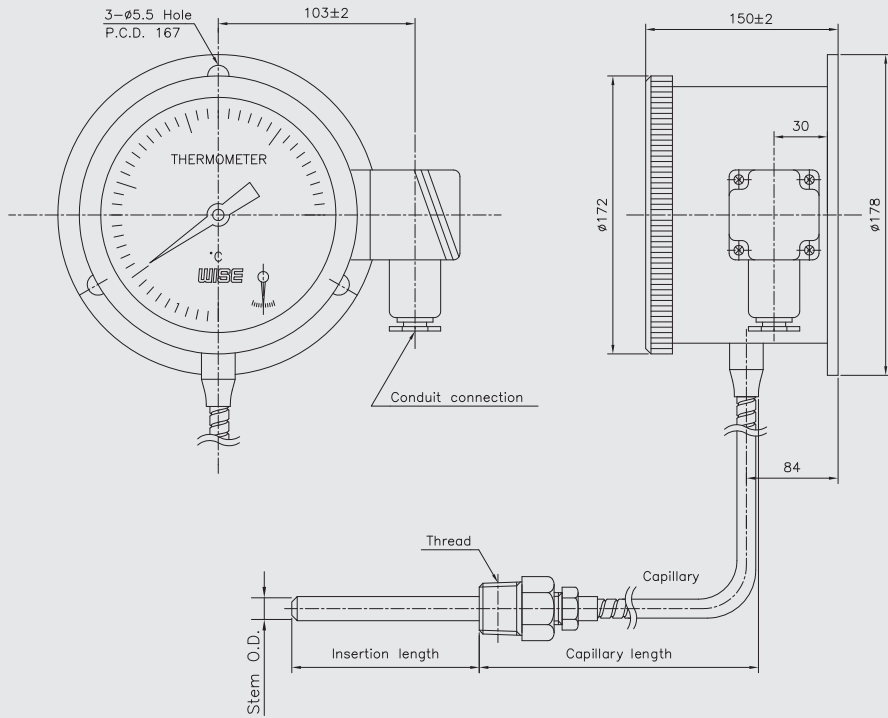

Code B

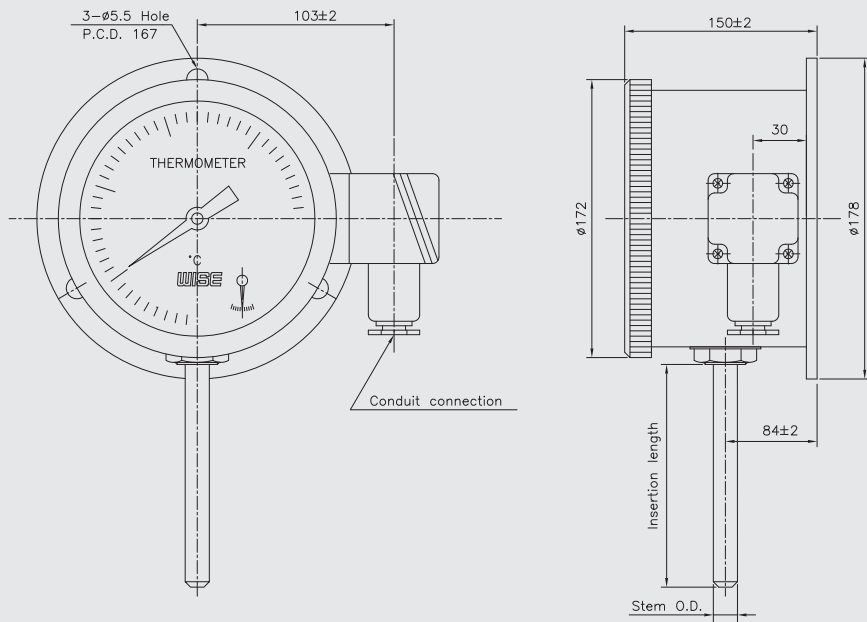

Scale ranges

Code	Scale range (°C)	Scale spacing(°C)	Minimum stem length (mm)					
			T931			T932		
			8.0	10.0	12.0	8.0	10.0	12.0
032	-50 ~ 50	2	100	85	65	X	X	X
037	-50 ~ 100	5	100	88	65	X	X	X
054	-30 ~ 50	2	100	85	65	X	140	90
059	-30 ~ 100	2	100	85	65	150	80	60
061	-30 ~ 120	5	100	85	65	150	80	60
069	-20 ~ 50	2	100	85	65	X	160	100
074	-20 ~ 100	2	100	85	65	150	80	60
079	-20 ~ 150	5	100	85	65	150	80	60
084	-10 ~ 50	1	100	85	65	X	180	110
099	0 ~ 50	1	100	85	65	X	190	120
100	0 ~ 60	1	100	85	65	X	180	110
101	0 ~ 70	2	100	85	65	X	160	100
102	0 ~ 80	2	100	85	65	X	140	90
104	0 ~ 100	2	100	85	65	180	100	70
106	0 ~ 120	2	100	85	65	150	80	60
109	0 ~ 150	5	100	85	65	150	80	60
114	0 ~ 200	5	100	85	65	150	80	60
119	0 ~ 250	5	100	85	65	X	X	X
124	0 ~ 300	5	100	85	65	X	X	X
129	0 ~ 350	5	100	85	65	X	X	X
134	0 ~ 400	10	100	85	65	X	X	X
144	0 ~ 500	10	100	85	65	X	X	X
154	0 ~ 600	10	100	85	65	X	X	X
164	0 ~ 700	10	100	85	65	X	X	X

* 0 ~ 700 °C/Special range

X : Not available

Insertion length

Code	1	2	3	4	5	6	7	8	9	A	B	C
Length (mm)	50	60	70	80	100	120	130	150	175	200	225	250

Code	D	E	F	G	H	J	K	L	M	N	P
Length (mm)	275	300	350	375	400	450	500	550	1,000	1,500	2,000