



IFC 050 Technical Datasheet

Signal converter for electromagnetic flowmeters

- For simple applications
- Multiple outputs, incl. active pulse output and RS485 Modbus
- Excellent price/performance ratio



The documentation is only complete when used in combination with the relevant documentation for the flow sensor.

1 Product features	3
1.1 The standard for simple applications	3
1.2 Options and variants	5
1.3 Signal converter/flow sensor combination possibilities	6
1.4 Measuring principle	6
2 Technical data	7
2.1 Technical data	7
2.2 Dimensions and weight	14
2.2.1 Housing	14
2.2.2 Mounting plate, wall version	16
2.3 Flow tables	17
2.4 Measuring accuracy	19
3 Installation	20
3.1 Intended use	20
3.2 Installation specifications	20
3.3 Mounting of the compact version	20
3.4 Mounting of the wall housing, remote version	20
4 Electrical connections	22
4.1 Safety instructions	22
4.2 Preparing the signal and field current cables	22
4.2.1 Signal cable A (type DS 300), construction	22
4.2.2 Length of signal cable A	23
4.2.3 Connection diagram for signal and field current cable	24
4.3 Grounding the flow sensor	25
4.4 Connecting the power supply	25
4.5 Inputs and outputs, overview	27
4.5.1 Description of the CG number	27
4.5.2 Fixed, non-alterable output versions	27
4.6 Laying electrical cables correctly	28
5 Notes	29

1.1 The standard for simple applications

The electromagnetic signal converter **IFC 050** is a perfect choice for measuring volumetric flow in various kinds of applications in the water industry but also in the food and beverage business.

The signal converter can be combined with the flow sensors OPTIFLUX 1000, 2000, 4000, 6000 and the WATERFLUX 3000. The output represents measured values for flow, mass and conductivity.

This low-cost signal converter has some specific features:

- An active pulse output for a simple system, like driving an electro-mechanical counter
- RS485 Modbus communication with a data processing system
- Extra insulation of the electronic device and housing for high performance in areas with extreme humidity and chances for flooding
- Cost-effective flow measurement for a wide range of process conditions and still a very acceptable degree of accuracy



- ① Large graphic display with 4 magnet keys for operating the signal converter when the housing is closed
- ② 4 push buttons to operate the signal converter when the housing is open
- ③ Supply voltage: 100...230 VAC and 24 VDC

Highlights

- Available outputs: current output (incl. HART®), active pulse/frequency output, status output and Modbus
- Intuitive operation with touch buttons
- Excellent price/performance ratio
- Modern robust housing design
- Asymmetric mounting possible
- All versions with and without display are available
- Simple installation and start-up
- Bright graphic display
- A variety of operating languages integrated as standard
- Certified tests for humidity and vibration
- Extremely quick signal conversion

Industries

- Water & Wastewater
- Food & Beverage
- Heating, Ventilation & Air Conditioning (HVAC)
- Agriculture
- Steel

Applications

- Water and wastewater treatment
- Water distribution network
- Irrigation installation
- Water abstraction
- CIP cleaning stations

1.2 Options and variants

Modular signal converter concept with display



The modular concept gives the opportunity to combine the IFC 050 with the flow sensors OPTIFLUX 1000, OPTIFLUX 2000, OPTIFLUX 4000, OPTIFLUX 6000 and the WATERFLUX 3000. With respect to the housing versions, both a compact and a remote design are available. The signal converter for the compact version is directly mounted under a 10° angle to the flow sensor for easy reading of the display after rainfall or frost.

If the measuring point is difficult to access or if the ambient conditions like temperature effects and vibration prevent the use of the compact version, a remote signal converter with a wall housing is available.

Remote version in wall housing with display



A signal cable is used to connect the flow sensor to the signal converter for power supply and signal processing.

The same electronic unit can be used in both [Compact + Wall] versions without configuration.

Remote version in wall housing without display



A blind version is the perfect option in a situation where the display is not required and the menu will be approached once a time.

A separate display can be easily connected to the electronic unit to enter the menu. This tool will be provided as a spare part.

1.3 Signal converter/flow sensor combination possibilities

Flow sensor	Flow sensor + signal converter IFC 050	
	Compact	Remote wall-mounted housing
OPTIFLUX 1000	OPTIFLUX 1050 C	OPTIFLUX 1050 W
OPTIFLUX 2000	OPTIFLUX 2050 C	OPTIFLUX 2050 W
OPTIFLUX 4000	OPTIFLUX 4050 C	OPTIFLUX 4050 W
OPTIFLUX 6000	OPTIFLUX 6050 C	OPTIFLUX 6050 W
WATERFLUX 3000	WATERFLUX 3050 C	WATERFLUX 3050 W

1.4 Measuring principle

An electrically conductive fluid flows inside an electrically insulated pipe through a magnetic field. This magnetic field is generated by a current, flowing through a pair of field coils.

Inside of the fluid, a voltage U is generated:

$$U = v \cdot k \cdot B \cdot D$$

in which:

v = mean flow velocity

k = factor correcting for geometry

B = magnetic field strength

D = inner diameter of flowmeter

The signal voltage U is picked off by electrodes and is proportional to the mean flow velocity v and thus the flow rate Q . A signal converter is used to amplify the signal voltage, filter it and convert it into signals for totalizing, recording and output processing.

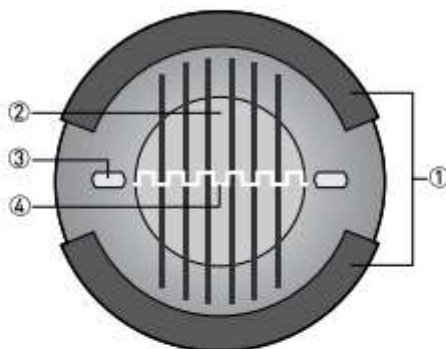

Figure 1-1: Measuring principle

- ① Field coils
- ② Magnetic field
- ③ Electrodes
- ④ Induced voltage [proportional to flow velocity]

2.1 Technical data

- *The following data is provided for general applications. If you require data that is more relevant to your specific application, please contact us or your local sales office.*
- *Additional information (certificates, special tools, software,...) and complete product documentation can be downloaded free of charge from the website (Downloadcenter).*

Measuring system

Measuring principle	Faraday's law of induction
Application range	Continuous measurement of current volume flow, flow velocity, conductivity, mass flow (at constant density), coil temperature of the flow sensor

Design

Modular construction	The measuring system consists of a flow sensor and a signal converter.
Flow sensor	
OPTIFLUX 1000	DN10...150 / 3/8...6"
OPTIFLUX 2000	DN25...1200 / 1...48"
OPTIFLUX 4000	DN10...1200 / 3/8...48"
OPTIFLUX 6000	DN10...150 / 3/8...6"
WATERFLUX 3000	DN25...600 / 1...24"
Signal converter	
Compact version (C)	IFC 050 C
Remote version (W)	IFC 050 W
Options	
Outputs	Current output (incl. HART®), pulse output, frequency output, status output and/or limit switch Note: It's not possible to use the pulse/frequency output with the status output at the same time!
Counter	2 internal counters with a max. of 10 counter places (e.g. for counting volume and/or mass units)
Verification	Integrated verification, diagnostic functions: measuring device, empty pipe detection, stabilisation
Communication interfaces	HART® Modbus

Display and user interface	
Graphic display	LC display, backlit white
	Size: 128 x 64 pixels, corresponds to 59 x 31 mm = 2.32" x 1.22"
	Ambient temperatures below -25°C / -13°F may affect the readability of the display.
Operating elements	4 push buttons for operating the signal converter when the housing is open.
	4 magnet keys for operating the signal converter when the housing is closed.
Remote control	Only generic and not device-specific DDs and DTMs available!
	PACTware™ (including Device Type Manager (DTM))
	HART® Hand Held Communicator from Emerson Process
	AMS® from Emerson Process
	PDM® from Siemens
	All DTMs and drivers are available free of charge from the manufacturer's website.
Display functions	
Operating menu	Setting the parameters using 2 measuring pages, 1 status page, 1 graphic page (measured values and graphics are freely adjustable)
Language display texts (as language package)	Standard: English, French, German, Dutch, Portuguese, Swedish, Spanish, Italian
	Eastern Europe: English, Slovenian, Czech, Hungarian
	Northern Europe: English, Danish, Polish, Finnish
	Southern Europe: English, Turkish
	China: English, German, Chinese
	Russia: English, German, Russian
Units	Metric, British and US units selectable as required from lists for volume / mass flow and counting, flow velocity, electrical conductivity, temperature

Measuring accuracy

Max. measuring accuracy	Standard: ±0.5% of the measured value ± 1 mm/s
	Option (optimised accuracy with extended calibration): ±0.25% of the measured value ± 1.5 mm/s
	For detailed information and accuracy curves refer to <i>Measuring accuracy</i> on page 19.
	Special calibrations are available on request.
	Current output electronics: ±10 µA; ±100 ppm/°C (typically: ±30 ppm/°C)
Repeatability	±0.1%

Operating conditions

Temperature	
Process temperature	Refer to technical data for the flow sensor.
Ambient temperature	Depending on the version and combination of outputs. It is a good idea to protect the converter from external heat sources such as direct sunlight as higher temperatures reduce the life cycle of all electronic components. Ambient temperatures below -25°C / -13°F may affect the readability of the display.
Storage temperature	-40...+70°C / -40...+158°F
Pressure	
Medium	Refer to technical data for the flow sensor.
Ambient pressure	Atmosphere
Chemical properties	
Electrical conductivity	All media except for water: $\geq 5 \mu\text{S/cm}$ [also refer to the technical data for the flow sensor] Water: $\geq 20 \mu\text{S/cm}$
State of aggregation	Conductive, liquid media
Solid content (volume)	$\leq 10\%$
Gas content (volume)	$\leq 3\%$
Flow rate	For detailed information, refer to chapter "Flow tables".
Other conditions	
Ingress protection acc. to IEC 529 / EN 60529	IP66/67 [acc. to NEMA 4/4X]

Installation conditions

Installation	For detailed information, refer to chapter "Installation conditions".
Inlet / outlet sections	Refer to technical data for the flow sensor.
Dimensions and weight	For detailed information refer to chapter "Dimensions and weight".

Materials

Signal converter housing	Aluminum with a polyester topcoat
Flow sensor	For housing materials, process connections, liners, grounding electrodes and gaskets, refer to technical data for the flow sensor.

Electrical connection

General	Electrical connection is carried out in conformity with the VDE 0100 directive "Regulations for electrical power installations with line voltages up to 1000 V" or equivalent national specifications.
Power supply	100...230 VAC (-15% / +10%), 50/60 Hz; 240 VAC + 5% is included in the tolerance range.
	24 VDC (-30% / +30%)
Power consumption	AC: 15 VA
	DC: 5.6 W
Signal cable	Only necessary for remote versions. DS 300 (type A) Max. length: 600 m / 1968 ft (depending on electrical conductivity and flow sensor version)
Cable entries	Standard: M20 x 1.5 (8...12 mm)
	Option: ½ NPT, PF ½

Outputs

General	All outputs are electrically isolated from each other and from all other circuits.
	All operating data and output values can be adjusted.
Description of abbreviations	U_{ext} = external voltage; R_L = load + resistance; U_o = terminal voltage; I_{nom} = nominal current

Current output	
Output data	Flow
Settings	Without HART®
	Q = 0%: 0...20 mA; Q = 100%: 10...21.5 mA
	Error identification: 20...22 mA
	With HART®
	Q = 0%: 4...20 mA; Q = 100%: 10...21.5 mA
Error identification: 3...22 mA	
Operating data	Basic I/Os
Active	Observe connection polarity.
	$U_{int, nom} = 20 \text{ VDC}$
	$I \leq 22 \text{ mA}$
	$R_L \leq 750 \Omega$
	HART® at terminals A
Passive	Observe connection polarity.
	$U_{ext} \leq 32 \text{ VDC}$
	$I \leq 22 \text{ mA}$
	$U_0 \leq 2 \text{ V}$ at $I = 22 \text{ mA}$
	$R_{L, max} = (U_{ext} - U_0) / I_{max}$
	HART® at terminals A
HART®	
Description	HART® protocol via active and passive current output
	HART® version: V5
	Universal Common Practice HART® parameter: completely supported
Load	$\geq 250 \Omega$ at HART® test point; Note maximum load for current output!
Multi-drop mode	Yes, current output = 4 mA
	Multi-drop address adjustable in operation menu 1... 15

Pulse or frequency output	
Output data	Flow
Function	Can be set as a pulse output or frequency output
Pulse rate/frequency	0.01...10000 pulses/s or Hz
Settings	Pulses per volume or mass unit or max. frequency for 100% flow
	Pulse width: adjustable as automatic, symmetric or fixed (0.05...2000 ms)
Operating data	Basic I/Os + Modbus
Active	This output is intended to drive mechanical or electronic counters directly.
	$U_{int, nom} \leq 20 \text{ V}$ $R_V = 1 \text{ k}\Omega$ $C = 1000 \mu\text{F}$
	High current mechanical counter $f_{max} \leq 1 \text{ Hz}$
	Low current mechanical counter $I \leq 20 \text{ mA}$ $R_L \leq 10 \text{ k}\Omega$ for $f \leq 1 \text{ kHz}$ $R_L \leq 1 \text{ k}\Omega$ for $f \leq 10 \text{ kHz}$ closed: $U_0 \geq 12.5 \text{ V}$ at $I = 10 \text{ mA}$ open: $I \leq 0.05 \text{ mA}$ at $U_{nom} = 20 \text{ V}$
Passive	Independent of connection polarity.
	$U_{ext} \leq 32 \text{ VDC}$
	f_{max} in operating menu set to $f_{max} \leq 100 \text{ Hz}$: $I \leq 100 \text{ mA}$ open: $I \leq 0.05 \text{ mA}$ at $U_{ext} = 32 \text{ VDC}$ closed: $U_{0, max} = 0.2 \text{ V}$ at $I \leq 10 \text{ mA}$ $U_{0, max} = 2 \text{ V}$ at $I \leq 100 \text{ mA}$
	f_{max} in operating menu set to $100 \text{ Hz} < f_{max} \leq 10 \text{ kHz}$: $I \leq 20 \text{ mA}$ open: $I \leq 0.05 \text{ mA}$ at $U_{ext} = 32 \text{ VDC}$ closed: $U_{0, max} = 1.5 \text{ V}$ at $I \leq 1 \text{ mA}$ $U_{0, max} = 2.5 \text{ V}$ at $I \leq 10 \text{ mA}$ $U_{0, max} = 5.0 \text{ V}$ at $I \leq 20 \text{ mA}$

Low flow cut off	
Function	Switching point and hysteresis separately adjustable for each output, counter and the display
Switching point	Set in increments of 0.1%. 0...20% (current output, frequency output) or 0...±9.999 m/s (pulse output)
Hysteresis	Set in increments of 0.1%. 0...5% (current output, frequency output) or 0...5 m/s (pulse output)
Time constant	
Function	The time constant corresponds to the elapsed time until 67% of the end value has been reached according to a step function.
Settings	Set in increments of 0.1 seconds. 0...100 seconds
Status output / limit switch	
Function and settings	Adjustable as automatic measuring range conversion, display of flow direction, counter overflow, error, switching point or empty pipe detection Valve control with activated dosing function Status and/or control: ON or OFF
Operating data	
Basic I/Os + Modbus	
Passive	Independent of connection polarity. $U_{ext} \leq 32 \text{ VDC}$ $I \leq 100 \text{ mA}$ open: $I \leq 0.05 \text{ mA}$ at $U_{ext} = 32 \text{ VDC}$ closed: $U_0 = 0.2 \text{ V}$ at $I \leq 10 \text{ mA}$ $U_0 = 2 \text{ V}$ at $I \leq 100 \text{ mA}$
Modbus	
Description	Modbus RTU, Master / Slave, RS485
Address range	1...247
Broadcast	Supported with function code 16
Supported Baud rate	1200, 2400, 3600, 4800, 9600, 19200, 38400, 57600, 115200 Baud

Approvals and certificates

CE	This device fulfils the statutory requirements of the relevant EU directives. The manufacturer certifies successful testing of the product by applying the CE mark. For full information of the EU directives & standards and the approved certifications, please refer to the EU declaration or the manufacturer website.
Other standards and approvals	
Shock and vibration resistance	IEC 60068-2-3; EN 60068-2-6 and EN 60068-2-27; IEC 61298-3
NAMUR	NE 21, NE 43, NE 53

2.2 Dimensions and weight

2.2.1 Housing

Wall version

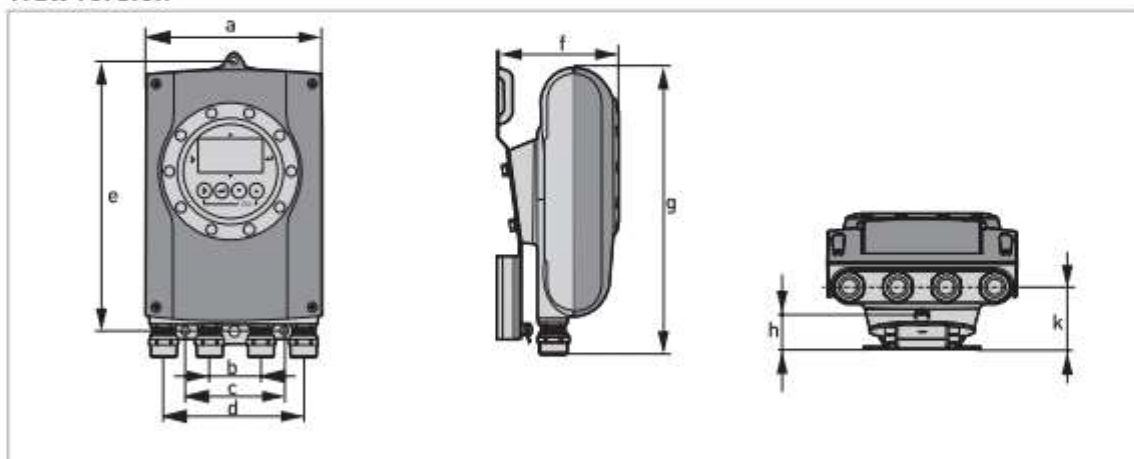

Dimensions and weight in mm and kg

	Dimensions [mm]									Weight [kg]
	a	b	c	d	e	f	g	h	k	
Version with & without display	157	40	80	120	248	111.7	260	28.4	51.3	1.9

Dimensions and weight in inch and lb

	Dimensions [inch]									Weight [lb]
	a	b	c	d	e	f	g	h	k	
Version with & without display	6.18	1.57	3.15	4.72	9.76	4.39	10.24	1.12	2.02	4.2

Compact version

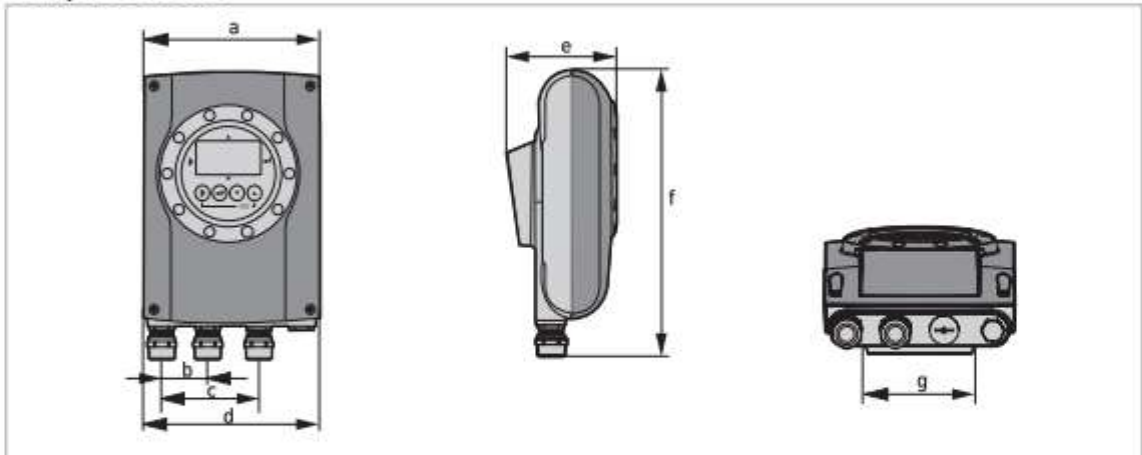

Dimensions and weight in mm and kg

	Dimensions [mm]							Weight [kg]
	a	b	c	d	e	f	g	
Version with & without display	157	40	80	148.2	101	260	95.5	1.8

Dimensions and weight in inch and lb

	Dimensions [inch]							Weight [lb]
	a	b	c	d	e	f	g	
Version with & without display	6.18	1.57	3.15	5.83	3.98	10.24	3.76	4.0

2.2.2 Mounting plate, wall version

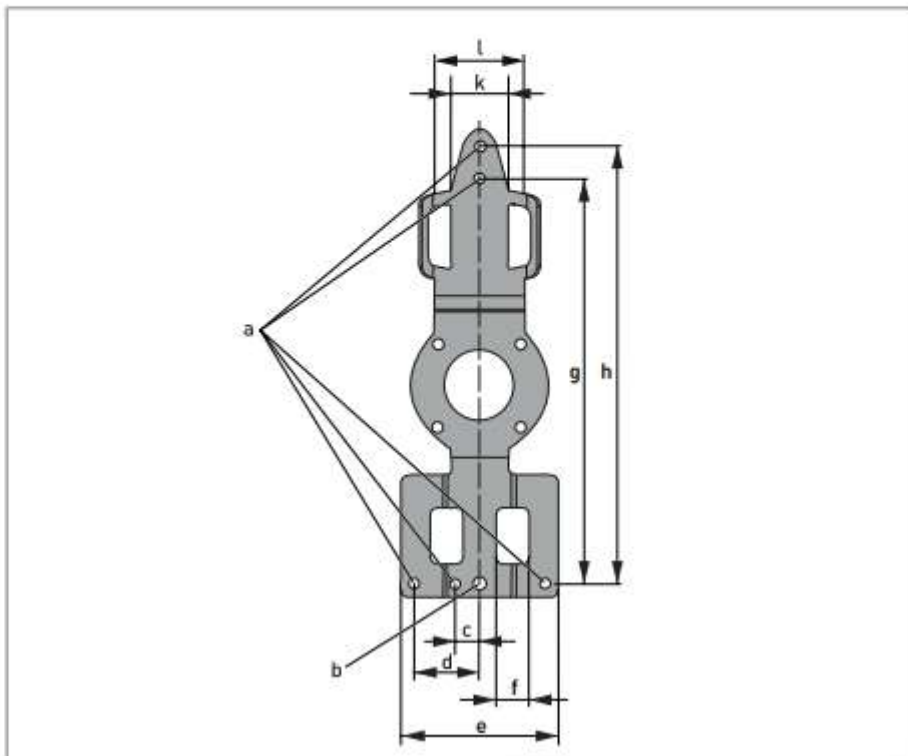

Dimensions in mm and inch

	[mm]	[inch]
a	Ø6.5	Ø0.26
b	Ø8.1	Ø0.3
c	15	0.6
d	40	1.6
e	96	3.8
f	20	0.8
g	248	9.8
h	268	10.5
k	35	1.4
l	55	2.2

2.3 Flow tables

Flow rate in m/s and m³/h

v [m/s]	Q _{100%} in m ³ /h			
	0.3	1	3	12
DN [mm]	Minimum flow	Nominal flow		Maximum flow
2.5	0.005	0.02	0.05	0.21
4	0.01	0.05	0.14	0.54
6	0.03	0.10	0.31	1.22
10	0.08	0.28	0.85	3.39
15	0.19	0.64	1.91	7.63
20	0.34	1.13	3.39	13.57
25	0.53	1.77	5.30	21.21
32	0.87	2.90	8.69	34.74
40	1.36	4.52	13.57	54.29
50	2.12	7.07	21.21	84.82
65	3.58	11.95	35.84	143.35
80	5.43	18.10	54.29	217.15
100	8.48	28.27	84.82	339.29
125	13.25	44.18	132.54	530.15
150	19.09	63.62	190.85	763.40
200	33.93	113.10	339.30	1357.20
250	53.01	176.71	530.13	2120.52
300	76.34	254.47	763.41	3053.64
350	103.91	346.36	1039.08	4156.32
400	135.72	452.39	1357.17	5428.68
450	171.77	572.51	1717.65	6870.60
500	212.06	706.86	2120.58	8482.32
600	305.37	1017.90	3053.70	12214.80
700	415.62	1385.40	4156.20	16624.80
800	542.88	1809.60	5428.80	21715.20
900	687.06	2290.20	6870.60	27482.40
1000	848.22	2827.40	8482.20	33928.80
1200	1221.45	3421.20	12214.50	48858.00

Flow rate in ft/s and US gallons/min

v [ft/s]	Q ₁₀₀ % in US gallons/min			
	1	3.3	10	40
DN [inch]	Minimum flow	Nominal flow		Maximum flow
1/10	0.02	0.09	0.23	0.93
1/8	0.06	0.22	0.60	2.39
1/4	0.13	0.44	1.34	5.38
3/8	0.37	1.23	3.73	14.94
1/2	0.84	2.82	8.40	33.61
3/4	1.49	4.98	14.94	59.76
1	2.33	7.79	23.34	93.36
1.25	3.82	12.77	38.24	152.97
1.5	5.98	19.90	59.75	239.02
2	9.34	31.13	93.37	373.47
2.5	15.78	52.61	159.79	631.16
3	23.90	79.69	239.02	956.09
4	37.35	124.47	373.46	1493.84
5	58.35	194.48	583.24	2334.17
6	84.03	279.97	840.29	3361.17
8	149.39	497.92	1493.29	5975.57
10	233.41	777.96	2334.09	9336.37
12	336.12	1120.29	3361.19	13444.77
14	457.59	1525.15	4574.93	18299.73
16	597.54	1991.60	5975.44	23901.76
18	756.26	2520.61	7562.58	30250.34
20	933.86	3112.56	9336.63	37346.53
24	1344.50	4481.22	13445.04	53780.15
28	1829.92	6099.12	18299.20	73196.79
32	2390.23	7966.64	23902.29	95609.15
36	3025.03	10082.42	30250.34	121001.37
40	3734.50	12447.09	37346.00	149384.01
48	5377.88	17924.47	53778.83	215115.30

2.4 Measuring accuracy

Every electromagnetic flowmeter is calibrated by direct volume comparison. The wet calibration validates the performance of the flowmeter under reference conditions against accuracy limits.

The accuracy limits of electromagnetic flowmeters are typically the result of the combined effect of linearity, zero point stability and calibration uncertainty.

Reference conditions

- Medium: water
- Temperature: +5...+35°C / +41...+95°F
- Operating pressure: 0.1...5 barg / 1.5...72.5 psig
- Inlet section: ≥ 5 DN
- Outlet section: ≥ 2 DN

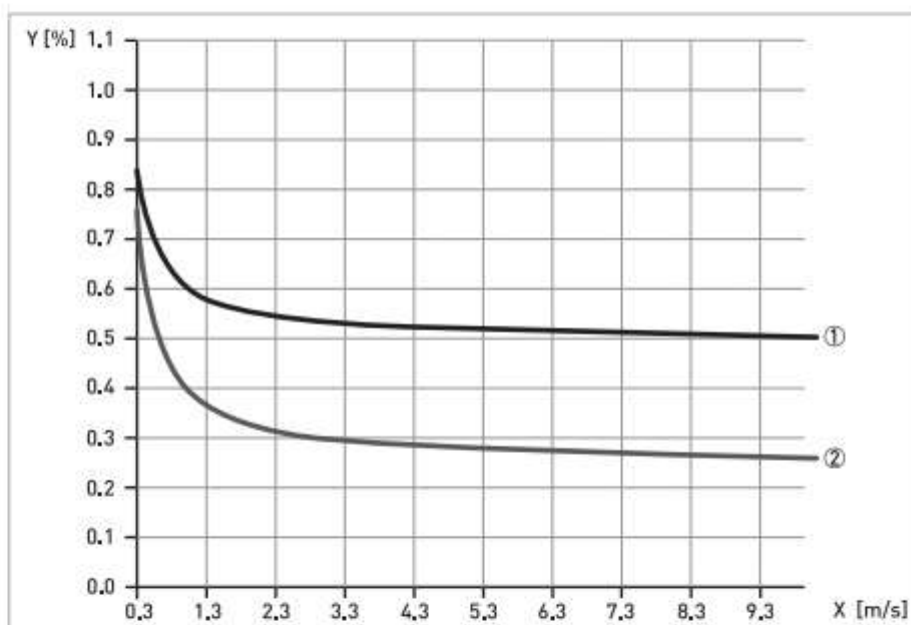

X [m/s]: flow velocity

Y [%]: Accuracy of measured value (mv)

	DN [mm]	DN [inch]	Standard accuracy ①	Optimised accuracy ②
OPTIFLUX 1050	10...150	3/8...6	$\pm 0.5\%$ of mv ± 1 mm/s	$\pm 0.25\%$ of mv ± 1.5 mm/s Extended calibration at 2 points
OPTIFLUX 2050	10...1200	3/8...48		
OPTIFLUX 4050				
OPTIFLUX 6050	10...150	3/8...6		
WATERFLUX 3050	25...600	1...24	-	-

3.1 Intended use

The electromagnetic flowmeters are designed exclusively to measure the flow and conductivity of electrically conductive, liquid media.

If the device is not used according to the operating conditions (refer to chapter "Technical data"), the intended protection could be affected.

This device is a Group 1, Class A device as specified within CISPR11:2009. It is intended for use in industrial environment. There may be potential difficulties in ensuring electromagnetic compatibility in other environments, due to conducted as well as radiated disturbances.

3.2 Installation specifications

The following precautions must be taken to ensure reliable installation.

- *Make sure that there is adequate space to the sides.*
- *Protect the signal converter from direct sunlight and install a sun shade if necessary.*
- *Signal converters installed in control cabinets require adequate cooling, e.g. by fan or heat exchanger.*
- *Do not expose the signal converter to intense vibrations. The measuring devices are tested for a vibration level in accordance with IEC 68-2-64.*

3.3 Mounting of the compact version

The signal converter is mounted directly on the flow sensor. For installation of the flowmeter, please observe the instructions in the supplied product documentation for the flow sensor.

3.4 Mounting of the wall housing, remote version

Assembly materials and tools are not part of the delivery. Use the assembly materials and tools in compliance with the applicable occupational health and safety directives.

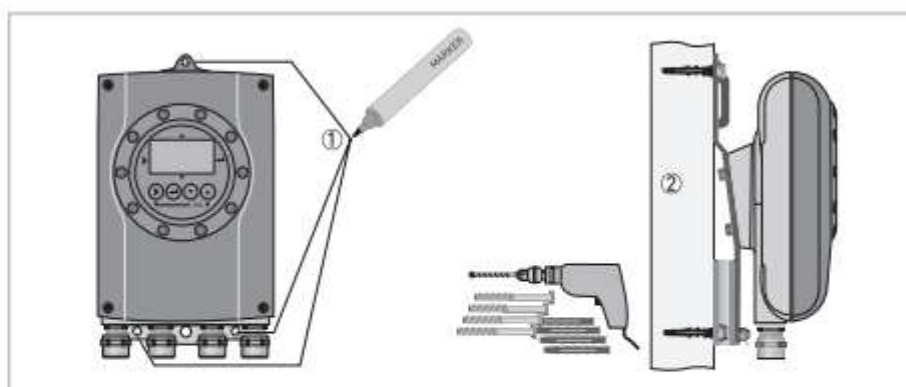

Figure 3-1: Mounting of the wall housing

- ① Prepare the holes with the aid of the mounting plate.
- ② Fasten the device securely to the wall with the mounting plate.

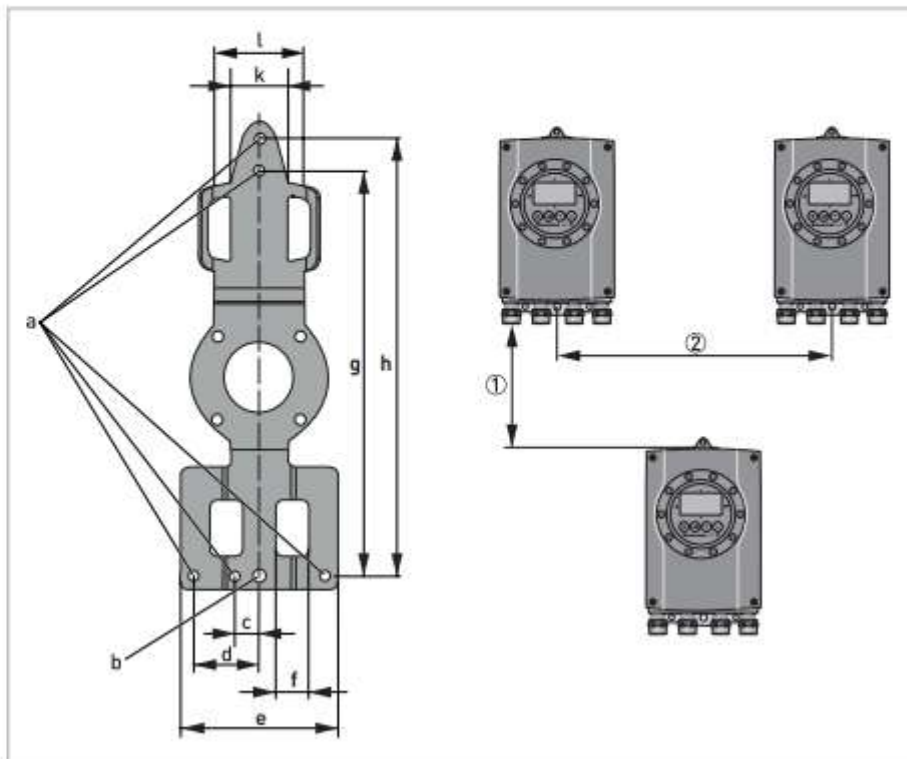

Figure 3-2: Dimensions of mounting plate and distances when mounting multiple devices next to each other

- ① 277 mm / 10.89"
 ② 310 mm / 12.2"

	[mm]	[inch]
a	Ø6.5	Ø0.26
b	Ø8.1	Ø0.3
c	15	0.6
d	40	1.6
e	96	3.8
f	20	0.8
g	248	9.8
h	268	10.5
k	35	1.4
l	55	2.2

4.1 Safety instructions

All work on the electrical connections may only be carried out with the power disconnected. Take note of the voltage data on the nameplate!

Observe the national regulations for electrical installations!

Observe without fail the local occupational health and safety regulations. Any work done on the electrical components of the measuring device may only be carried out by properly trained specialists.

Look at the device nameplate to ensure that the device is delivered according to your order. Check for the correct supply voltage printed on the nameplate.

4.2 Preparing the signal and field current cables

Assembly materials and tools are not part of the delivery. Use the assembly materials and tools in compliance with the applicable occupational health and safety directives.

4.2.1 Signal cable A (type DS 300), construction

- Signal cable A is a double-shielded cable for signal transmission between the flow sensor and signal converter.
- Bending radius: $\geq 50 \text{ mm} / 2''$

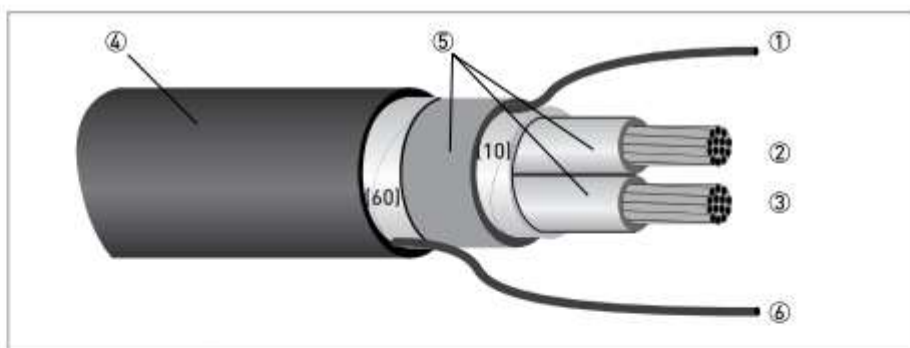

Figure 4-1: Construction of signal cable A

- ① Stranded drain wire [1] for the inner shield [10], $1.0 \text{ mm}^2 \text{ Cu} / \text{AWG } 17$ (not insulated, bare)
- ② Insulated wire [2], $0.5 \text{ mm}^2 \text{ Cu} / \text{AWG } 20$
- ③ Insulated wire [3], $0.5 \text{ mm}^2 \text{ Cu} / \text{AWG } 20$
- ④ Outer sheath
- ⑤ Insulation layers
- ⑥ Stranded drain wire [6] for the outer shield [60]

4.2.2 Length of signal cable A

For temperatures of the medium above 150°C / 300°F, a special signal cable and a ZD intermediate socket are necessary. These are available including the changed electrical connection diagrams.

Flow sensor	Nominal size		Min. electrical conductivity [$\mu\text{S}/\text{cm}$]	Curve for signal cable A
	DN [mm]	[inch]		
OPTIFLUX 1000 F	10...150	3/8...6	20	A1
OPTIFLUX 2000 F	25...150	1...6	20	A1
	200...1200	8...48	20	A2
OPTIFLUX 4000 F	10...150	3/8...6	20	A1
	200...1200	8...48	20	A2
OPTIFLUX 6000 F	10...150	3/8...6	20	A1
WATERFLUX 3000 F	25...600	1...24	20	A1

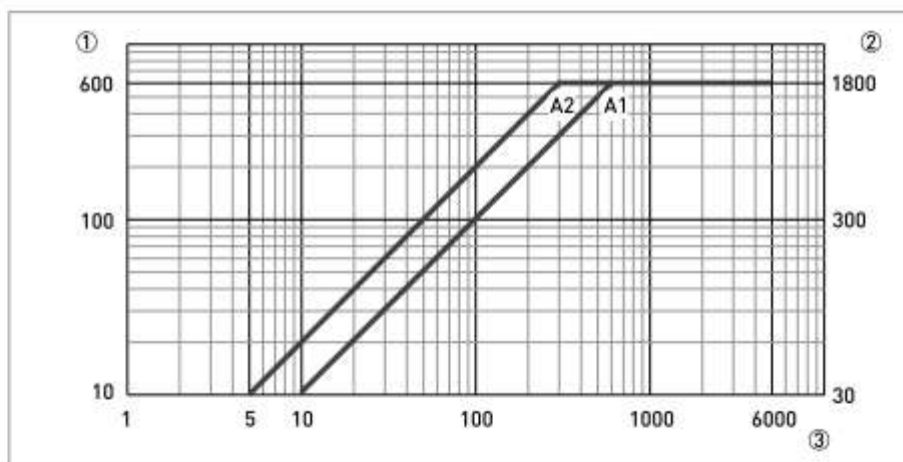

Figure 4-2: Maximum length of signal cable A

- ① Maximum length of signal cable A between the flow sensor and signal converter [m]
- ② Maximum length of signal cable A between the flow sensor and signal converter [ft]
- ③ Electrical conductivity of the medium being measured [$\mu\text{S}/\text{cm}$]

4.2.3 Connection diagram for signal and field current cable

The device must be grounded in accordance with regulations in order to protect personnel against electric shocks.

- A shielded 2-wire copper cable is used as the field current cable. The shielding **MUST** be connected in the housing of the flow sensor and signal converter.
- The outer shield (60) is connected in the terminal compartment of the flow sensor directly via the shield and a clip.
- Bending radius of signal and field current cable: $\geq 50 \text{ mm} / 2''$
- The following illustration is schematic. The positions of the electrical connection terminals may vary depending on the housing version.

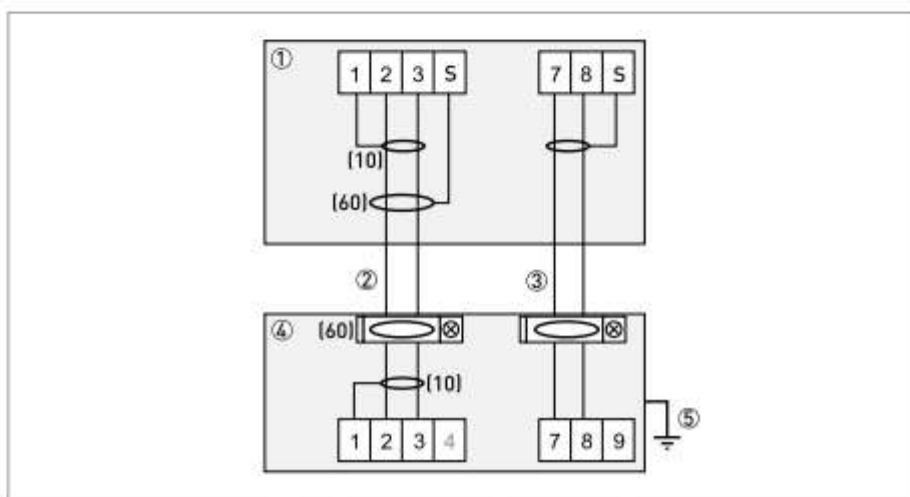

Figure 4-3: Connection diagram for signal and field current cable

- ① Electrical terminal compartment in the signal converter
- ② Signal cable A
- ③ Field current cable C
- ④ Electrical terminal compartment in the flow sensor
- ⑤ Functional ground FE

4.3 Grounding the flow sensor

There should be no difference in potential between the flow sensor and the housing or protective earth of the signal converter!

- The flow sensor must be properly grounded.
- The grounding cable should not transmit any interference voltages.
- Do not use the grounding cable to connect any other electrical devices to ground at the same time.
- The flow sensors are connected to ground by means of a functional grounding conductor FE.
- Special grounding instructions for the various flow sensors are provided in the separate documentation for the flow sensor.
- The documentation for the flow sensor also contain descriptions on how to use grounding rings and how to install the flow sensor in metal or plastic pipes or in pipes which are coated on the inside.

4.4 Connecting the power supply

- *To protect operators from electrical shock, during installation the cable for the power supply **must** be run with sheathing insulation up to the mains cover. The insulated individual wires have to be only below the mains cover!*
- *If there is no mains cover or if it has been lost, the 100...230 VAC device may only be operated from the outside (with a magnet pencil) while closed!*
- The housings of the devices, which are designed to protect the electronic equipment from dust and moisture, should be kept well closed at all times. Creepage distances and clearances are dimensioned to VDE 0110 and IEC 664 for pollution severity 2. Supply circuits are designed for overvoltage category III and the output circuits for overvoltage category II.
- Fuse protection ($I_N \leq 16$ A) for the infeed power circuit, and also a separator (switch, circuit breaker) to isolate the signal converter must be provided.

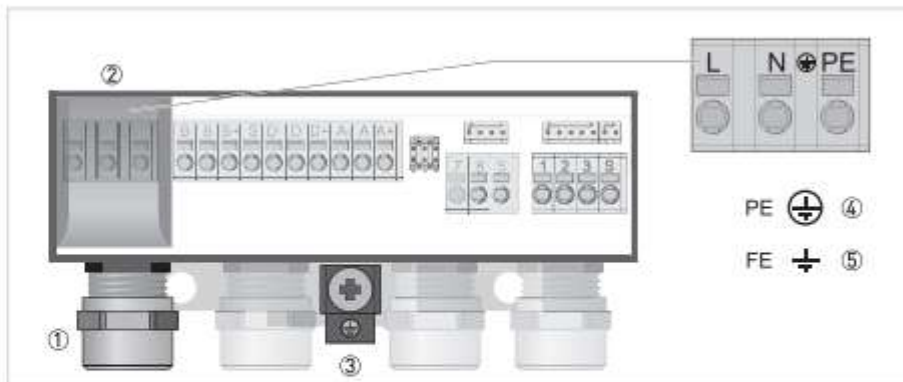

Figure 4-4: Terminal compartment for power

- ① Cable entry for power supply
- ② Mains cover
- ③ Ground terminal
- ④ 100...230 VAC [-15% / +10%]
- ⑤ 24 VDC [-30% / +30%]

- To open the cover of the electrical terminal compartment, lightly press in the side walls of the mains cover ②.
- Flip the mains cover up.
- Connect the power supply.
- Close the mains cover again by flipping it down.

100...230 VAC (tolerance range: -15% / +10%)

- Note the power supply voltage and frequency (50...60 Hz) on the nameplate.

240 VAC + 5% is included in the tolerance range.

24 VDC (tolerance range: -30% / +30%)

- Note the data on the nameplate!
- When connecting to functional extra-low voltages, provide a facility for protective separation (PELV) (acc. to VDE 0100 / VDE 0106 and/or IEC 364 / IEC 536 or relevant national regulations).

4.5 Inputs and outputs, overview

4.5.1 Description of the CG number



Figure 4-5: Marking (CG number) of the electronics module and output variants

- ① ID number: 0
- ② ID number: 0 = standard; 9 = special
- ③ Power supply
- ④ Display (language versions)
- ⑤ Output version

4.5.2 Fixed, non-alterable output versions

This signal converter is available with various output combinations.

- The grey boxes in the tables denote unassigned or unused connection terminals.
- In the table, only the final digits of the CG no. are depicted.
- Terminals D- and A- are connected for active pulse/frequency output (no galvanic isolation anymore).
- Available are an active or passive pulse/frequency output, or the active or passive status/limit output. It's not possible to use both at the same time!

Basic outputs (I/Os)

CG no.	Connection terminals						
	S	D-	D	D+	A-	A	A+
1 0 0 R 0 0	①	P _p / S _p passive			I _p + HART® passive ②		
		connected to A-	P _a active		connected to D-	I _a + HART® active ②	
		P _p / S _p passive			I _a + HART® active ②		

① Shielding

② Function changed by reconnecting

Modbus (I/O) (option)

CG no.	Connection terminals			
	B-	B	B+	S
R 0 0	Sign. A (D0-)	Common	Sign. B (D1+)	Shielding

Description of used abbreviations

I _a	I _p	Current output active or passive
P _a	P _p	Pulse/frequency output active or passive
S _a	S _p	Status output/limit switch active or passive

4.6 Laying electrical cables correctly

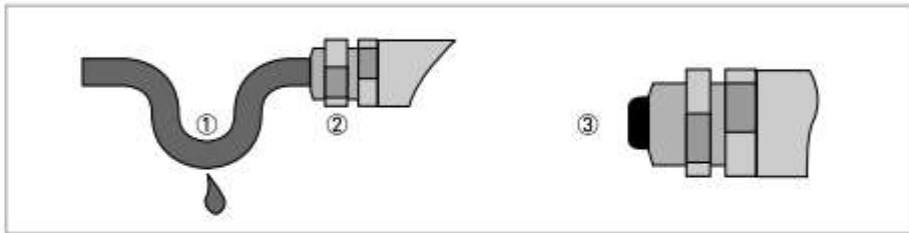

Figure 4-6: Protect housing from dust and water

- ① For compact versions with nearly horizontally-oriented cable entries, lay the necessary electric cables with a drip loop as shown in the illustration.
- ② Tighten the screw connection of the cable entry securely.
- ③ Seal cable entries that are not needed with a plug.



KROHNE – Process instrumentation and measurement solutions

- Flow
- Level
- Temperature
- Pressure
- Process Analysis
- Services

Head Office KROHNE Messtechnik GmbH
Ludwig-Krohne-Str. 5
47058 Duisburg (Germany)
Tel.: +49 203 301 0
Fax: +49 203 301 10389
info@krohne.com

The current list of all KROHNE contacts and addresses can be found at:
www.krohne.com

KROHNE