



# Digital Controller

Temperature/Process Controller

## FZ Series



Reinforced Insulation



## Makes the machine look sharp

The outstanding design of the FZ which is beyond the common image of panel meters dramatically changes the first impression of your machine.

- Three Indicators
- Thin bezel
- Selectable PV (Universal input)
- Selectable Remote input (Universal input)
- Measuring Accuracy :  $\pm 0.1\%$  of reading
- Sampling Time : 0.05 sec.
- Selectable Control method (Heat/Cool)
- Two Input Control (FZ400/900)
- Easy maintenance with plug-in construction (FZ400/900)
- Easy data back up through the front loader port

## Wide range display (5 digits)

# FZ Series



# Customizable versatile information display

## ■ Three Indicators (FZ400/900)



• CT and CT input hardware are required. (Option)

### CT input display

Enables display of load factor of the heater controlling the process and detects potential errors at an early stage.

Control Output : %  
Memory Area Soak Time (Progress time of segment) : H:M / M:S  
Current transformer (CT) Input Value : A

High accuracy type CT(CTL-6-P-Z) can be used too.

Accurately measures current 1A or less.

CTL-6-P-Z  
(U.R.D.Co.,LTD product)  
Measured range : 0.0 to 10.0A  
Accuracy : ±0.3A



## ■ Display Customization

### Parameter Select Function

Select and display only necessary parameters.

“Set Value • Event 4”



Set value
Event 1
Event 2
Event 3
Event 4
Proportional Band
Integral Time
Derivative Time
Control Response
Proactive intensity
FF Amount
⋮
⋮

## ■ Numerous Inputs and Outputs

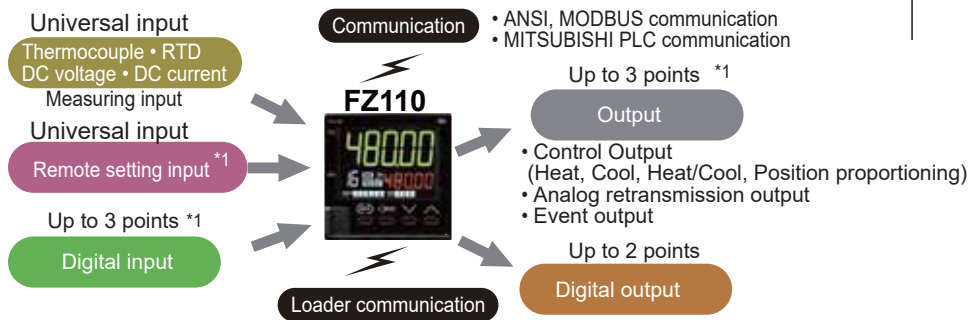

\*1 The number of inputs/outputs is limited depending on the specifications.

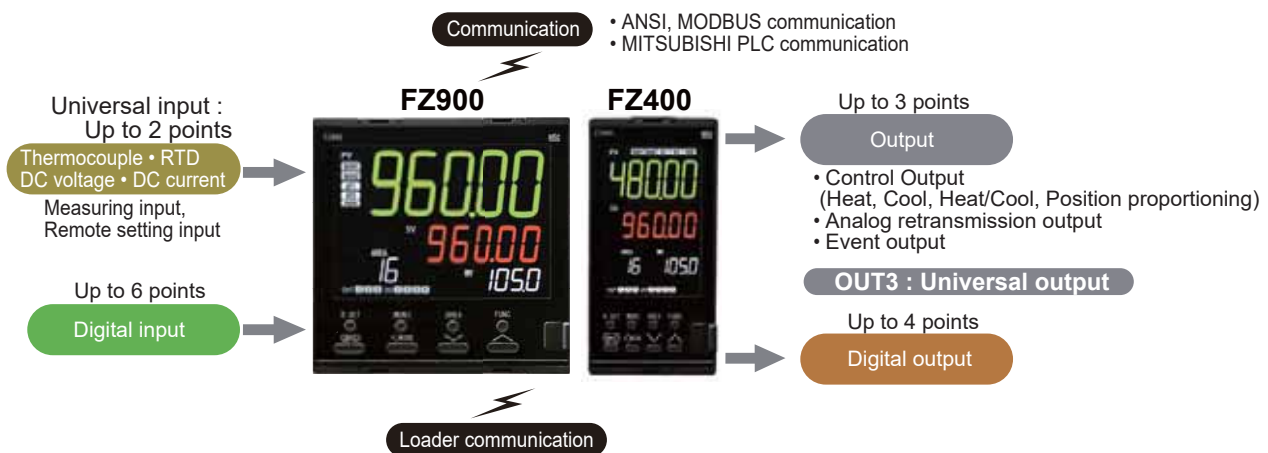

# 2 inputs for various applications

• Two-input type is available for FZ400/900 only.

## ■ 2 Loop Control

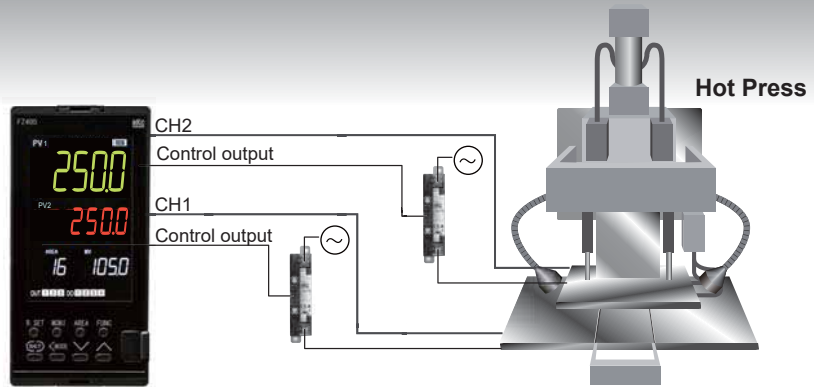

## ■ Cascade Control

(Control loop combination function)

Available with functions related to Cascade control and dedicated Autotuning.

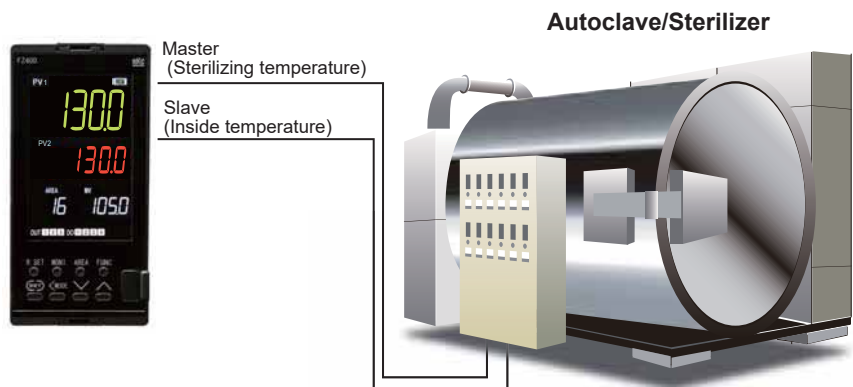

## ■ Control with PV select

This is a function to switch between Input 1 and Input 2 at a preset temperature.

- This function may be appropriate in such an application where a thermocouple (whose operating temperature range is relatively low) and a radiation pyrometer (which can be used for high temperature applications) are used being switched between them.

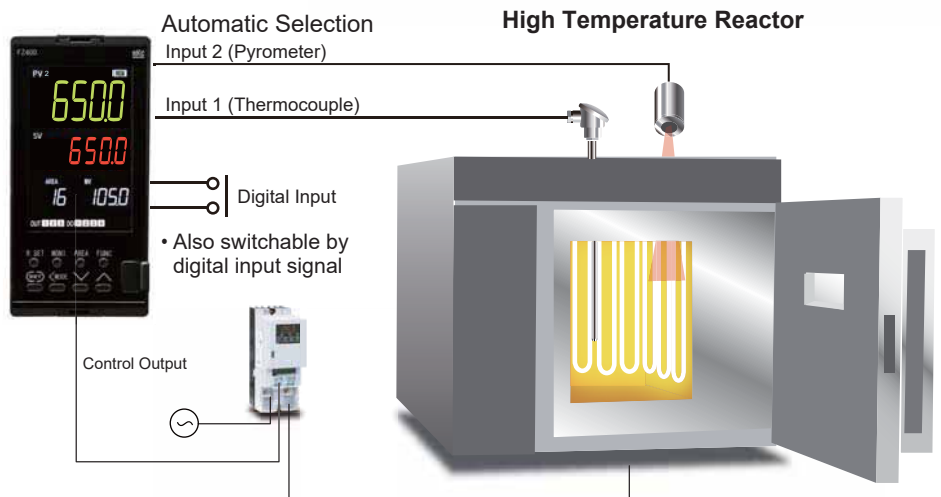

## ■ Math Control

This is a function to control to maintain constant difference between PV of Input 1 and Input 2.

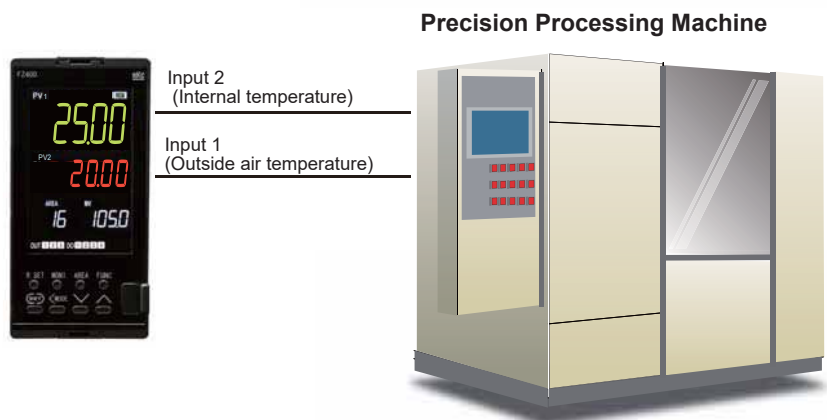



# Advanced control performance and function

## ■ Suppresses fluctuations due to overshoot and external disturbance.

### ● Suppressing Overshoot **Proactive Function**

Proactive function suppresses overshoot and provides fast and stable control. Adjustable Proactive Intensity allows the FZ to be tuned appropriate for various process applications. Determines response based on the deviation amount and speed and adjusts the PID factors using fuzzy logic operation.

P.A. : Proactive

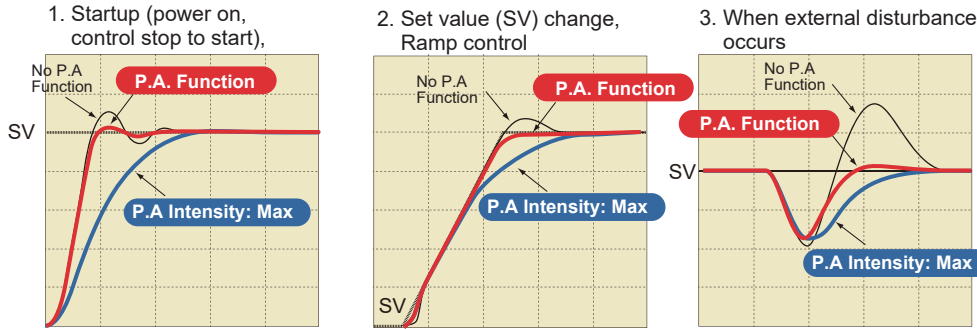

Proactive Intensity setting : 0: No function, 1 (Min), 2, 3, 4(Max), Default setting : 2

### ● Bottom suppression function

When the input fluctuation by external disturbance is detected, the amount of FF (Feed forward) is added to the output value to suppress the Bottom.

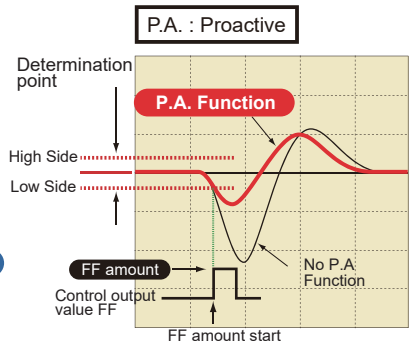

• Adding the FF amount can be triggered by either DI or communication.

## ■ Automatic selection of PID values appropriate for temperature zones

### Level PID Function

The FZ stores a maximum of 8 preset PID settings and automatically switches from one PID setting to another depending on the preset SV or PV level. Thus, the process can be controlled with the optimum PID setting.

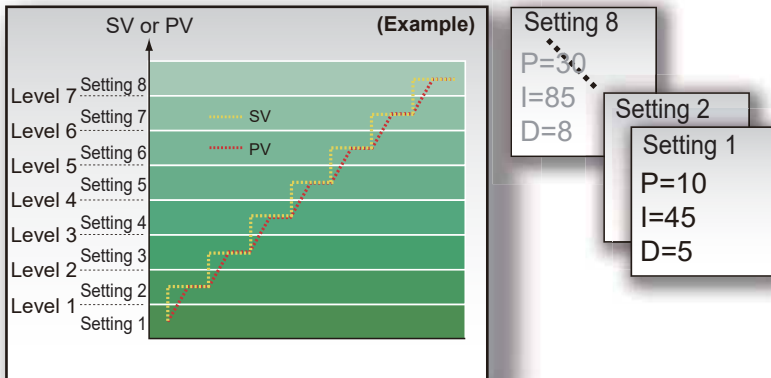

Parameters of Memory area at Level PID

Proportional band (Heat side/Cool side), Integral time (Heat side/Cool side), Derivative time (Heat side/Cool side), Control response, Overlap/Deadband, Manual reset, Proactive intensity, FF amount, LBA time, LBA dead band, Output limiter High/Low (Heat side/Cool side)

## ■ Switching Direct/Reverse action by DI (Digital Input)

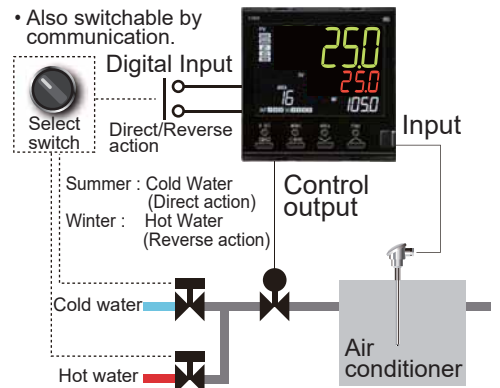

## ■ Ramp/Soak Program Control

Up to 16-segment ramp/soak control is available by using the Memory Area function (area soak time, link area number, ramp-to-setpoint Up and Down).

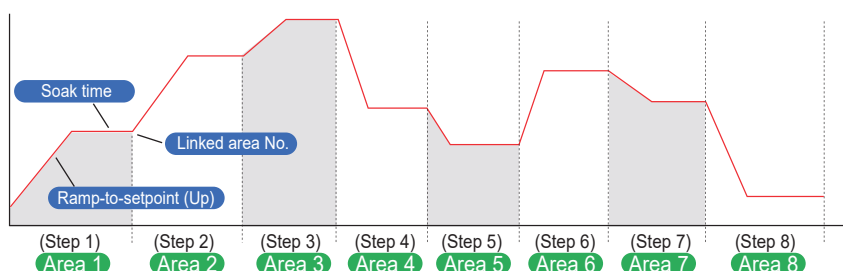

### Need more segment

The PF900 is a powerful ramp/soak controller with a large program storage capacity of 1024 segments (99 patterns with 10 segments each to 10 patterns with 99 segments each).



# Easy connection to PC and PLC

A loader communication port is available on the 48mm square sized front panel

All models are supplied with a front loader port as standard. Configuration software can be used without removing the controller from the panel.

The power to COM-K2 is supplied from the PC via the USB port so no power supply is necessary.



Loader communication cable  
Length : 1.5m  
Model code for cable only :  
W-BV-05-1500

### USB communication converter COM-K2

COM-K2-4  
(With loader communication cable)  
COM-K2-N  
(Without loader communication cable)

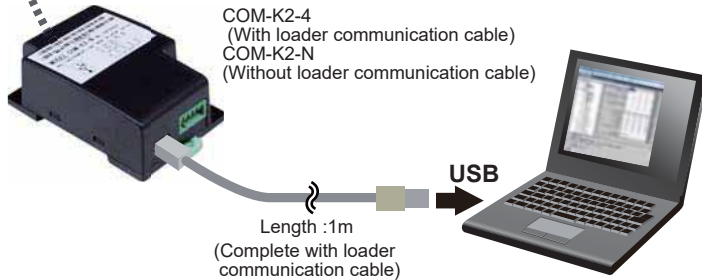

### Easy Data Management Communication Tool **PROTEM 2**

Data monitoring, setting, storage, copy, transfer, logging, and report creation



Simply download "PROTEM2" from the RKC Instrument website ([www.rkcinst.com](http://www.rkcinst.com)).

## Programless connection to PLCs

(Optional)

PLC Special Protocol (MAPMAN Function)

A PLC special protocol (MAPMAN) function becomes a Master Unit to PLC, and automatically stores temperature data into registers in a PLC.

This enables easy handling of temperature control system to the existing PLC system is available.

(MITSUBISHI PLC Protocol : QnA compatible, 3C frame (type 4))

### MAPMAN

MITSUBISHI MELSEC series



# Functions and performance designed for easy maintainability

## Easy Maintenance

The internal assembly of the FZ400/900 can be removed from the front.

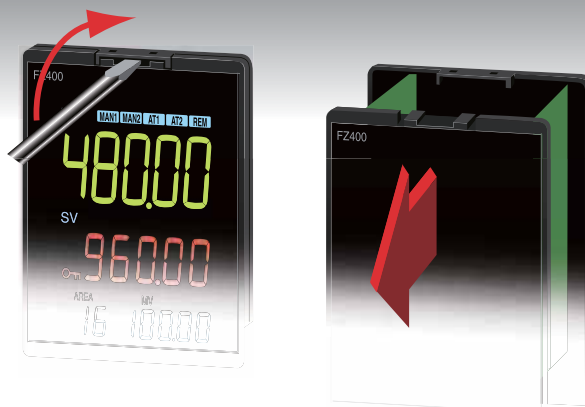

## Flexible Output Configuration

OUT1, OUT2

- : Relay contact/Voltage pulse/Current/Continuous voltage/Transistor output

OUT3

- : Voltage pulse/Current (Universal output)

DO1, DO2, DO3, DO4 \*1

- : Relay contact

Output type is freely changeable to meet the requirements of different applications.

(\*1) FZ110: 2 points (DO1, DO2)



Control output (Heat/Cool)

Control output (Position proportioning)

Event output

LBA output

HBA output

RUN status monitor output

Output of communication monitoring result

Manual status output

Remote status output

AT status output

SV change status output

FAIL output

Retransmission output

OUT1

OUT2

OUT3

(Universal output)

DO1

DO2

DO3 (\*2)

DO4 (\*2)

(\*2) FZ400/900 only

## Universal Output (OUT3)

OUT3 (Output 3) can be configured to voltage pulse output or continuous current output.

The output can be configured to control output or retransmission output.



OUT3 (Universal output)

- Voltage pulse (Control output)
- Current (Control output/Retransmission output)

Selectable

## Long Operation Life

Use of high performance control relay assures long term operation.



**Electrical Life (Relay contact output)**  
: 300,000 operations or more

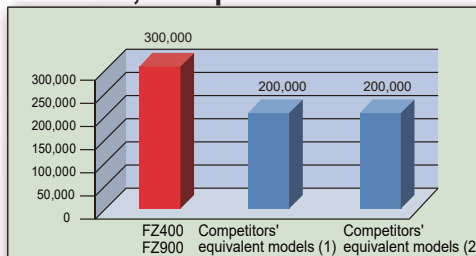

**Mechanical life (Relay contact output)**  
: 50,000,000 operations or more

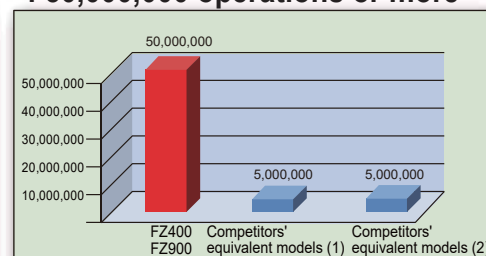

· Data when used at a rated value. Depending on the operating conditions, there may be some exceptions that we cannot guarantee.  
· Applies to the control output relays mounted on OUT1 and OUT2 of FZ400/900.

## Reinforced Insulated Power Supply Circuit

Power supply circuit of the FZ Series has been designed to provide reinforced insulation, eliminating the necessity of providing basic insulation on the machine side for cost saving.

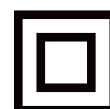

<Requirements for electrical equipment according to safety standards>

The safety standard for electrical equipment (IEC 61010-1 and JIS C1010-1) requires the secondary side of the equipment which may be accessible by the operator to be double insulated or reinforced insulated\* for protection of the operators against electric shock.

- Insulation equal to or better than double insulation for protecting personnel from electric shock is termed "reinforced insulation".

## Measured Input (Universal Inputs)

### a) Group 1

Input	Measured range	Reference	
K	-200.0 to +400.0°C, -328.0 to +752.0°F -200.0 to +1372.0°C, -328.0 to +2502.0°F	JIS/IEC	
J	-200.0 to +400.0°C, -328.0 to +752.0°F -200.0 to +1200.0°C, -328.0 to +2192.0°F		
T	-200.0 to +400.0°C, -328.0 to +752.0°F		
S	-50 to +1768°C, -58 to +3214°F		
R	-50 to +1768°C, -58 to +3214°F		
E	-200 to +1000°C, -328 to +1832°F		
B	0 to 1800°C, 0 to 3272°F		
N	0 to 1300°C, 0 to 2372°F		
PLII	0 to 1390°C, 0 to 2534°F		NBS
W5Re/W26Re	0 to 2300°C, 0 to 4200°F		ASTM
U	-200.0 to +600.0°C, -328.0 to +1112.0°F		DIN
L	0.0 to 900.0°C, 0.0 to 1652.0°F		
PR40-20	0 to 1800°C, 0 to 3200°F	ASTM	
Pt100	-200.0 to +850.0°C, -328.0 to +1562.0°F -100.00 to +100.00°C, -148.00 to +212.00°F 0.00 to 50.00°C, 32.00 to 122.00°F	JIS/IEC • 3-wire system	
JPt100	-200.0 to +640.0°C, -328.0 to +1184.0°F -100.00 to +100.00°C, -148.00 to +212.00°F 0.00 to 50.00°C, 32.00 to 122.00°F	JIS • 3-wire system	
Low Voltage	0 to 10mV DC, 0 to 100mV DC		

### b) Group 2

Input	Measured range
High Voltage	0 to 1V DC, 0 to 5V DC, 1 to 5V DC, 0 to 10V DC -5 to +5V DC, -10 to +10V DC

### c) Group 3

Input	Measured range
Current	0 to 20mA DC, 4 to 20mA DC

#### Number of inputs

FZ400/FZ900 : Max. 2 points  
• Isolated between each channel  
FZ110 : 1 point

Influence of external resistance : Approx. 0.18μV/Ω (Thermocouple input)

Influence of lead resistance : Approx. 0.006% of Span/Ω (RTD input)  
• Maximum 100Ω per wire

#### Input impedance (Voltage/Current Input)

Low voltage : 1MΩ, or more, High voltage : 1MΩ or more  
Current : Approx. 50Ω,

#### Input Break Action

Thermocouple input : Up-scale/Down-scale (Selectable)  
RTD input : Up-scale  
Low voltage input : Up-scale/Down-scale (Selectable)  
Current input : Value around 0mA  
High voltage input : Value around 0V

Input short action (RTD Input) : Down-scale (Except 0.00 to 50.00°C)  
Up-scale (0.00 to 50.00°C)

#### Measured input correction

a) PV bias : -span to +span  
b) PV ratio : 0.500 to 1.500  
c) PV digital filter : 0.1 to 100.0 sec. (OFF when 0 is set.)

## Current Transformer (CT) Input <Optional>

#### Number of inputs

FZ400/FZ900 : 2 points  
FZ110 : 1 point

#### CT Type

CTL-6-P-Z, CTL-6-P-N, CTL-12-S56-10L-N

#### CT input range

CTL-6-P-Z : 0.0 to 10.0A (High accuracy type)  
CTL-6-P-N : 0.0 to 30.0A  
CTL-12-S56-10L-N : 0.0 to 100.0A

Sampling Time : 0.5 sec

## Digital Input (DI) <Optional>

#### Number of inputs

FZ400/FZ900 : Max. 6 points (DI1 to DI6)  
FZ110 : Max. 3 points (DI1 to DI3)

Input method : Non-voltage contact input

OFF (Open state) : 50 kΩ or more

ON (Close state) : 1 kΩ or less

Capture judgment time : Within 200 ms

Function : Run/Stop, Auto/Mabual (Input 1/Input 2 : Common/Individual\*)  
Remote/Local (Cascade mode select\*, PV select\*,  
2-loop control\*/Differential temperature control\*), Interlock release,  
Peak/Bottom hold reset (Input 1/Input 2 : Common/Individual\*)  
Autotuning ON/OFF (Input 1/Input 2 : Common/Individual\*)  
Unlock/Lock, Direct/Reverse action, Area select, Area jump  
\* FZ400/900 only

## Performance

Sampling Time : 0.05 sec

• When Input 2 is configured for 2-loop control or cascade control: 0.1 seconds.

### Measuring display accuracy table

Input Type	Range	Accuracy
K, J, T, E, U, L	Lower than -100°C (-148°F)	± (1.0°C [1.8°F] + 1 digit) [Approximate value]
	-100 to 500°C (-148 to 932°F)	± (0.5°C [0.9°F] + 1 digit)
	500°C (932°F) or higher	± (0.1% of Reading + 1 digit)
N, R, S, PLII W5Re/W26Re	Lower than 0°C (32°F)	± (2.0°C [3.6°F] + 1 digit) [Approximate value]
	0 to 1000°C (32 to 1832°F)	± (1.0°C [1.8°F] + 1 digit)
	1000°C (1832°F) or higher	± (0.1% of Reading + 1 digit)
B	Lower than 400°C (752°F)	± (70°C [126°F] + 1 digit) [Approximate value]
	400 to 1000°C (752 to 1832°F)	± (1.4°C [2.52°F] + 1 digit)
	1000°C (1832°F) or higher	± (0.1% of Reading + 1 digit)
PR40-20	Lower than 400°C (752°F)	± (20°C [36°F] + 1 digit) [Approximate value]
	400 to 1000°C (752 to 1832°F)	± (10°C [18°F] + 1 digit)
	1000°C (1832°F) or higher	± (0.1% of Reading + 1 digit)
Pt100, JPt100	Lower than 200°C (392°F)	± (0.2°C [0.36°F] + 1 digit)
	200°C (392°F) or higher	± (0.1% of Reading + 1 digit)
	0.00 to 50.00°C (90.00°F)	± (0.10°C [0.18°F] + 1 digit)
Voltage/Current	-span to +span	± (0.1% of span + 1 digit)

• Display accuracy:

Is equal to the above accuracy with the value below the minimum resolution rounded up.

\*1 : Accuracy is not guaranteed for less than -100°C

\*2 : Accuracy is not guaranteed for less than 400°C (752°F) for Input Type R, S, B, PR20-40 and W5Re/W26Re.

### Resolution

a) Thermocouple : 1/200000 (PR40-20, B : 1/100000)

b) RTD : -200 to +850°C : 1/200000,  
-100.00 to +100.00°C/0.00 to 50.00 : 1/60000

c) Voltage/Current : 0 to 10mV : 1/120000, Except 0 to 10mV : 1/200000

## Control

Control method : Control Brilliant II PID control

Control action : PID control, Heat/Cool type PID control,  
Position proportioning control without feedback resistance  
• P, PI, PD, ON/OFF control selectable  
• Direct action/Reverse action is selectable

Other control function :

Manual control, Cascade control, 2 inputs control (Differential temperature control, Control with PV select, Input circuit error alarm), Proactive intensity, Level PID, Startup tuning

Additional function :

Inverting the Input, Temperature compensation calculation, Parameter select

Proportional band :

TC/RTD input : 0(0.0) to span (°C, °F)  
Voltage/Current input : 0.0 to 1000.0% of span  
(ON/OFF control when P = 0)  
• Differential gap at ON/OFF control (High/Low individual setting) :  
TC/RTD input : 0(0.0) to span (°C, °F)  
Voltage/Current input : 0.0 to 100.0% of span

Cool side proportional band :

TC/RTD input : 0(0.0) to span (°C, °F)  
Voltage/Current input : 0.0 to 1000.0% of span  
• Heat-side and Cool-side are both ON/OFF control when P = 0.  
• Only cooling side ON/OFF control is not available.

Integral time : 0 to 3600 sec, 0.0 to 3600.0 sec or 0.00 to 360.00 sec

(PD control when I = 0) (Heat/Cool individual setting)

Derivative time : 0 to 3600 sec, 0.0 to 3600.0 sec or 0.00 to 360.00 sec

(PI control when D = 0) (Heat/Cool individual setting)

Control response : Slow, Medium, Fast

Proportional cycle time : 0.1 to 100.0 sec (Heat/Cool individual setting)

Output limiter : -5.0 to +105.0% (High/Low individual setting)

Output change rate limiter :  
0.0 to 100.0%/sec (Up/Down individual setting) , (OFF when 0 is set.)

Output at Control Stop mode :  
-5.0 to +105.0% (Heat/Cool individual setting)

Overlap/Deadband :

TC/RTD input : -span to +span (°C, °F)  
Voltage/Current input : -100.0 to +100.0% of input span

Undershoot suppression factor : 0.0 to 1.0

Overlap/Deadband reference point :

0.0 to 1.0  
(0.0: Proportional band on heat-side, 1.0: Proportional band on cool-side,  
0.5: Midpoint)

Control motor time (Position proportioning control) : 5 to 1000 sec

Control motor integral output limiter (Position proportioning control) : 0.0 to 200.0%

Output at control stop mode (Position proportioning control) :

a) Close : Output off, Open : Output off  
b) Close : Output on, Open : Output off  
c) Close : Output off, Open : Output on

Action at saturated output (Position proportioning control) :

Invalid : The close-side output remains ON when the valve position is fully closed  
The open-side output remains ON when the valve position is fully opened  
Valid : The close-side output remains ON when the valve position is fully closed  
The open-side output remains ON when the valve position is fully opened

Level PID function

8 types of PID parameters are selectable according to the position of the Set value (SV) or the Measured value (PV).

a) Number of levels : 8 levels (PID memory group 1 to 8)

b) Stored parameters :

Proportional band (Heat side/Cool side), Integral time (Heat side/Cool side),  
Derivative time (Heat side/Cool side), Control response, Overlap/Deadband,  
Manual reset, Proactive intensity, FF amount, LBA time, LBA dead band,  
Output limiter High/Low (Heat side/Cool side)



## ● Output

- Output signal : OUT1, 2 : Relay contact output, Voltage pulse output, Current output, Continuous voltage, Transistor output  
OUT3 : Voltage pulse, Current output (Universal output)  
DO1, DO2 (FZ110) : Relay contact output  
DO1 to DO4 (FZ400/900) : Relay contact output
- Output function : Control output (Heat/Cool), Event output, LBA (Control loop break alarm output), HBA (Heater break alarm output), RUN status monitor, Output of communication monitoring result  
Manual status output, Remote status output, AT status output, SV change status output, FAIL output, Retransmission output
- Number of event/alarm : Up to 4 points
- Output specification
- Relay contact output (1), [OUT1, OUT2 of FZ110]
- Contact type : 1a contact, 250V AC 3A, 30V DC 1A (Resistive load)
  - Electric life : 100,000 operations or more (Rated load)
  - Mechanical life : 20,000,000 operations or more (Switching: 300 times/min)
- Relay contact output (2), [OUT1 of FZ400/900]
- Contact type : 1c contact, 250V AC 3A, 30V DC 1A (Resistive load)
  - Electric life : 300,000 operations or more (Rated load)
  - Mechanical life : 50,000,000 operations or more (Switching: 180 times/min)
- Relay contact output (3), [OUT2 of FZ400/900]
- Contact type : 1a contact, 250V AC 3A, 30V DC 1A (Resistive load)
  - Electric life : 300,000 operations or more (Rated load)
  - Mechanical life : 50,000,000 operations or more (Switching: 180 times/min)
- Relay contact output (4), [DO1, DO2 of FZ110, DO1 to DO4 of FZ400/900]
- Contact type : 1a contact, 250V AC 1A, 30V DC 0.5A (Resistive load)
  - Electric life : 150,000 operations or more (Rated load)
  - Mechanical life : 20,000,000 operations or more (Switching: 300 times/min)
- Voltage pulse output (1), [OUT1, OUT2 of FZ110/400/900]  
0/12V DC (Load resistance : More than 500W)
- Voltage pulse output (2), [OUT3 of FZ110/400/900]  
0/14V DC (Load resistance : More than 600W)
- Current output  
4 to 20mA, 0 to 20mA (Load resistance : Less than 500W)
- Continuous voltage output  
0 to 5V DC, 1 to 5V DC, 0 to 10V DC (Load resistance : More than 1kW)
- Transistor output
- Load voltage : Less than 30V DC
  - Load current : Less than 100mA

## ● Analog Retransmission Output (AO)

- Output type : Measured value (PV), Set value (SV), Manipulated value (MV), Deviation (between PV and SV), Current transformer (CT) input value, Measured value (PV) of differential temperature input  
• Selectable

## ● Event, Alarm function

- Type : Process high, Process low, Process high/low\*1, Deviation high, Deviation low, Deviation high/low\*1, Band\*1, Set value high, Set value low, Set value high/low  
MV value high (Heat/Cool), MV value low (Heat/Cool), FBR input  
\*1: Two types of alarm settings are field-selectable.
- Independent high and low settings.
  - Common high/low setting  
(Factory setting, unless specified in alarm code when ordering)
- Hold/Re-hold action, Delay timer, Energized/de-energized action, Interlock (latch) function, Alarm lamp ON condition available.
- Control loop break alarm (LBA)  
LBA time : 0 to 7200 sec (LBA is OFF when 0 is set.)  
Dead band : 0 to input span
- Heater break alarm (HBA)
- Number of alarm : FZ110: 1 point,  
FZ400/900 2 points (1 point per CT input)
  - Setting range : 0.0 to 100.0A  
(0.0: HBA function OFF [Current value monitoring is still available])  
• CT does not detect current value when the control output ON time or control output OFF time is less than 250 ms.
  - Delay times : 0 to 255 times  
• Heater break alarm is available for time proportioning output only.
- Output logic calculation : OR logic calculation from event 1 to 4, HBA1/2, LBA1/2  
Input abnormal 1/2 (High/Low)

## ● Multi-Memory Area (recipe)

- Number of memory area : 16 areas (recipes)
- Stored parameters : Set value (SV), Ramp-to-setpoint (Up/Down), Output limiter High/Low [Heat/Cool], Soak time, Linking area number, Event set values 1 to 4, Remote/Local select, Auto/Manual select, MV value, Area trigger select, Proportional band (Heat/Cool), Integral time (Heat/Cool) Derivative time (Heat/Cool), Control response parameter, Manual reset, Overlap/Deadband, Proactive intensity, FF amount, Control loop break alarm (LBA) time, LBA deadband
- Method of area select : Key operations/Communication function/External contact signal/Area soak time/Event function.
- Memory area link function
- Area soak time : 0 hr 00 min to 99 hr 59 min, 0 min 00 sec to 199min 59 sec  
0 min 00 sec to 9 hr 59 min 59 sec (FZ400/900 only)
  - Linking area number : 0 to 16

## ● Host communication (Optional)

- Communication method : RS-485, RS-422A (FZ400/900 only)  
Protocol : a) ANSI X3.28 sub-category 2.5A4 (RKC standard)  
b) MODBUS-RTU  
c) PLC communication (MAPMAN)
- Bit format : Data bit 7 or 8 (MODBUS-RTU : 8 bit fix)  
Parity bit 1(odd or even) or none  
Stop bit 1 or 2
- Communication speed : 2400bps, 4800bps, 9600bps, 19200bps, 38400bps  
57600bps
- Maximum connection : 31 units

## ● Loader communication

- Protocol : ANSI X3.28 sub-category 2.5 A4  
Communication speed : 38400bps  
Connection : 1 unit  
Method of connection : Exclusive cable (COM-K2)

## ● General Specifications

- Supply voltage
- 85 to 264V AC (50/60Hz, Selectable), Rating : 100 to 240V AC
  - 20.4 to 26.4V AC (50/60Hz, Selectable), Rating : 24V AC
  - 20.4 to 26.4V DC Rating : 24V DC
- Power consumption/Rush current
- 100 to 240V AC type  
FZ110 : Max. 5.2VA (100V), Rush current : Less than 5.6A  
Max. 8.1 VA (240V), Rush current : Less than 13.3A  
FZ400 : Max. 6.6VA (100V), Rush current : Less than 5.6A  
Max. 9.8VZ (240V), Rush current : Less than 13.3A  
FZ900 : Max. 7.2VA (100V), Rush current : Less than 5.6A  
Max. 10.6VA (200V), Rush current : Less than 13.3A
  - 24V AC type  
FZ110 : Max. 5.2VA (24V), Rush current : Less than 16.3A  
FZ400 : Max. 6.7VA (24V), Rush current : Less than 16.3A  
FZ900 : Max. 7.2VA (24V), Rush current : Less than 16.3A
  - 24V DC type  
FZ110 : Max. 126mA (24V), Rush current : Less than 11.5A  
FZ400 : Max. 170mA (24V), Rush current : Less than 11.5A  
FZ900 : Max. 185mA (24V), Rush current : Less than 11.5A
- Insulation resistance  
More than 20MW (500V DC) between measured terminals and ground  
More than 20MW (500V DC) between power terminals and ground
- Dielectric voltage  
1500V AC for one minute between measured terminals and ground  
1500V AC for one minute between power terminals and ground
- Power failure
- 100 to 240V AC, 24V AC type  
A power failure of 20m sec or less will not affect the control action.  
If power failure of more than 20m sec occurs, controller will restart with the state of HOT start 1, HOT start 2 or COLD start (selectable)
  - 24V DC type  
A power failure of 5m sec or less will not affect the control action.  
If power failure of more than 5m sec occurs, controller will restart with the state of HOT start 1, HOT start 2 or COLD start (selectable)
- Memory backup  
Backed up by non-volatile memory (FRAM)
- Data retaining period : Approx. 10 years
  - Number of writing : Approx. 1,000,000,000,000 times.  
(Depending on storage and operating conditions.)
- Waterproof/Dustproof (Optional)  
IP65 (IEC60529)
- Waterproof/Dustproof protection only effective from the front in panel mounted installation.
  - When the front loader connector cover is not installed: IP00
- Ambient temperature : -10 to +55°C (14 to 131°F)  
Ambient humidity : 5 to 95% RH (Non condensing)  
(MAX.W.C 29g/m<sup>3</sup> dry air at 101.3kPa)
- Weight  
FZ110 : Approx.122g, FZ400 : Approx.221g, FZ900 : 291g
- Compliance with Standards
- UL : UL61010-1
  - cUL : CAN/CSA-C22.2 No.61010-1
  - CE Mark  
LVD : EN61010-1  
EMC : EN61326-1  
RoHS : EN50581
  - RCM : EN55011



# Model and Suffix Codes

FZ400/900

		①	②	③	④	⑤	⑥	⑦	⑧	⑨	⑩	⑪	⑫
	48 x 96mm (1/8 DIN Vertical size) FZ400	□ □ □ □ - □ □ □ * □ □ □ □ □ □ □ □ □ □											
	96 x 96mm (1/4 DIN size) FZ900	□ □ □ □ - □ □ □ * □ □ □ □ □ □ □ □ □ □											
①	Control Method	PID control with AT (Reverse action) PID control with AT (Direct action) Heat/Cool PID control with AT Heat/Cool PID control with AT for extruder (Air cooling type) Heat/Cool PID control with AT for extruder (Water cooling type) Position proportional PID control without FBR (Reverse action) Position proportional PID control without FBR (Direct action)	F D G A W Z C										
②	Input and range	See Input range Code Table	□ □ □ □										
③	Output 1 (OUT1) (*1)	Not supplied	N										
		Relay contact output	M										
		Voltage pulse output (0/12V DC)	V										
		DC mA, V See Output Code Table	□										
		Transistor output	B										
④	Output 2 (OUT2) (*1)	Not supplied	N										
		Relay contact output	M										
		Voltage pulse output (0/12V DC)	V										
		DC mA, V See Output Code Table	□										
		Transistor output	B										
⑤	Power Supply	24V AC/DC				3							
		100 to 240V AC					4						
⑥	Digital output (*2)	Digital output 1 point							1				
		Digital output 4 points								4			
⑦	Option 1 (*3)	Not supplied	N										
		CT input 2 points (CTL-6-P-N)	T										
		CT input 2 points (CTL-12-S56-10L-N)	U										
		CT input 2 points (CTL-6-Z)	V										
		Feedback resistance input (FBR)	W										
⑧	Option 2 (*3)	Not supplied	N										
		Output 3 (OUT3)	A										
		Digital input 1 to 6 (DI1 to 6)	B										
		Communication RS-422A	C										
		Communication RS-485	D										
		Output 3 (OUT3) + Digital input 1 to 6 (DI1 to 6)	E										
		Output 3 (OUT3) + Communication RS-422A	F										
		Output 3 (OUT3) + Communication RS-485	G										
		Output 3 (OUT3) + Digital input 1 to 6 (DI1 to 6) + Communication RS-422A	H										
		Output 3 (OUT3) + Digital input 1 to 6 (DI1 to 6) + Communication RS-485	J										
⑨	Option 3 (*3) <i>(Caution1)</i>	Not supplied	N										
		Remote setting input	1										
		Measured input 2	2										
⑩	Display color	Standard								N			
⑪	Waterproof/ Dustproof	Not supplied	N										
		Waterproof/Dustproof protection (IP65)									1		
⑫	Quick start code	No quick start code (Default setting)										N	
		Specify quick start code (DO type)											1

Caution 1 : When Heat/Cool PID control or Position proportional PID control is selected, Select code "N" or "1" .

< Default setting of Output 1 (OUT1), Output 2 (OUT2), and Digital output >  
Quick start code not specified : Output allocation code "1" .

< Default setting of Option function >

- CT input  
CT1 assignment: Output 1 (OUT1)  
CT2 assignment: PID control (without Measured input 2) : Output 1 (OUT1)  
PID control (with Measured input 2) : Output 2 (OUT2)  
Heat/Cool PID control : Output 2 (OUT2)  
Position proportioning PID control : Output 2 (OUT2)
- Output 3 (OUT3)  
Current output (4 to 20mA), Analog retransmission output (Input 1 measured value)
- Digital input (DI)  
Option 2 : Code "B" , "E" , "J"  
DI1 to D3 : Memory area select (8 points, No set signal)  
DI4 : RUN/STOP \*  
DI5 : AUTO/MAN \*\*  
DI6 : Interlock release,  
Option 2 : Code "H"  
DI1 to D3 : Memory area select (8 points, No set signal)  
DI4 : RUN/STOP \*
- \* When " Remote setting input" is specified at Option 3, this will be configured to "Remote/Local transfer" .  
\*\* When "Measured input 2" is specified at Option 3, "Auto/Manual transfer" will be assigned to Input 1 and Input 2.
- Communication  
When quick start code not specified : RKC standard communication (ANSI X3.28-1976).  
The digit of the communication data depends on the Input range code
- Remote setting input  
When quick start code not specified : 0 to 10V DC, The range will be same as input 1.
- Measured input 2  
2-Loop control. Input range and the Control action will be the same as Measured input 1.

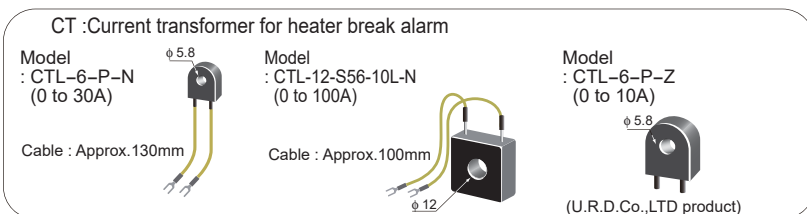

## Input Range Code Table (Universal input, Field-programmable) Thermocouple

Input	Range	Code
K	0 to 200°C	K01
	0 to 400°C	K02
	0 to 600°C	K03
	0 to 800°C	K04
	0 to 1200°C	K06
	0 to 1372°C	K07
	-199.9 to +300.0°C	K08
	0.0 to 400.0°C	K09
	0.0 to 800.0°C	K10
	0 to 300°C	K14
	-200 to +1372°C	K41
	-200.0 to +1372.0°C	K42
	0 to 800°F	KA1
	0 to 1600°F	KA2
0 to 2502°F	KA3	
J	0 to 200°C	J01
	0 to 400°C	J02
	0 to 600°C	J03
	0 to 800°C	J04
	0.0 to 400.0°C	J08
	-200.0 to +1200.0°C	J29
	0 to 800°F	JA1
	0 to 2192°F	JA3
0 to 400°F	JA6	
T	-199.9 to +400.0°C	T01
	-199.9 to +100.0°C	T02
	-100.0 to +200.0°C	T03
	-200.0 to +400.0°C	T19
S	-50 to +1768°C	S06
	0 to 1600°C	R01
R	-50 to +1768°C	R07
	0 to 800°C	E01
E	0 to 1800°C	B03
	0 to 1300°C	N02
PLII	0 to 1300°C	A01
	0 to 2300°C	W03
W5Re/ W26Re	0 to 1800°C	F02
	0 to 3200°F	FA2
PR40-20	0 to 3200°F	FA2
	-199.9 to +600.0°C	U01
U	-199.9 to +600.0°C	U01
	0.0 to 900.0°C	U04

## RTD

Input	Range	Code	
Pt100	-199.9 to +649.0°C	D01	
	-100.0 to +100.0°C	D04	
	-100.0 to +200.0°C	D05	
	0.0 to 50.0°C	D06	
	0.0 to 100.0°C	D07	
	0.0 to 200.0°C	D08	
	0.0 to 300.0°C	D09	
	0.0 to 500.0°C	D10	
	-199.9 to +600.0°C	D12	
	-200.0 to +200.0°C	D21	
	0.00 to 50.00°C	D27	
	-100.00 to +100.00°C	D34	
	-200.0 to +850.0°C	D35	
	-199.9 to +999.9°F	DA1	
	0.0 to 500.0°F	DA9	
	0.0 to 200.0°C	P08	
	JP100	-100.00 to +100.00°C	P29
		-200.0 to +640.0°C	P30

## DC Current - voltage

Input	Code	Range
0 to 10mV DC	101	Scale range and decimal point are programmable in the range of -19999 to +99999
0 to 100mV DC	201	
0 to 1V DC	301	
0 to 5V DC	401	
0 to 10V DC	501	
1 to 5V DC	601	
0 to 20mA DC	701	Factory set value 0.0 to 100.0%
4 to 20mA DC	801	
-10 to +10V DC	904	
-5 to +5V DC	905	

## C) Output Code Table

Output	Code
0 to 5V DC	4
0 to 10V DC	5
1 to 5V DC	6
0 to 20mA DC	7
4 to 20mA DC	8

48 x 48mm (1/16 DIN size) FZ110		①	②	③	④	⑤	⑥	⑦	⑧	⑨	⑩	⑪
① Control Method	PID control with AT (Reverse action)	F										
	PID control with AT (Direct action)	D										
	Heat/Cool PID control with AT	G										
	Heat/Cool PID control with AT for extruder (Air cooling type)	A										
	Heat/Cool PID control with AT for extruder (Water cooling type)	W										
	Position proportional PID control without FBR (Reverse action)	Z										
	Position proportional PID control without FBR (Direct action)	C										
② Input and range	See Input range Code Table											
	Not supplied					N						
③ Output 1 (OUT1) (*1)	Relay contact output					M						
	Voltage pulse output (0/12V DC)					V						
	DC mA, V See Output Code Table											
	Transistor output					B						
	Not supplied					N						
④ Output 2 (OUT2) (*1)	Relay contact output					M						
	Voltage pulse output (0/12V DC)					V						
	DC mA, V See Output Code Table											
	Transistor output					B						
	Not supplied					N						
⑤ Power Supply	24V AC/DC						3					
	100 to 240V AC						4					
⑥ Digital output (*2)	Not supplied							N				
	Digital output 1 point							1				
	Digital output 4 points							2				
⑦ Option 1 (*3)	Not supplied							N				
	Digital input 1 point + Remote setting input							A				
	Digital input 1 point + Output 3 (OUT3)							B				
	Digital input 1 point + CT input 1 point (CTL-6-P-N)							C				
	Digital input 1 point + CT input 1 point (CTL-12-S56-10L-N)							D				
	Digital input 1 point + CT input 1 point (CTL-6-P-Z)							E				
	Digital input 3 points							F				
⑧ Option 2	Not supplied							N				
	Communication RS-485							A				
⑨ Display color	Standard								N			
⑩ Waterproof/Dustproof	Not supplied									N		
	Waterproof/Dustproof protection (IP65)										1	
⑪ Quick start code	No quick start code (Default setting)											N
	Specify quick start code (DO type)											1

< Default setting of Output 1 (OUT1), Output 2 (OUT2), and Digital output >  
 Quick start code not specified  
 : Output allocation code "1".

< Default setting of Option function >  
 • Digital input (DI)  
 Option 1 : Code "A"  
 DI1 : Remote/Local  
 Option 1 : Code "B", "C", "D", "E"  
 DI1 : RUN/STOP \*  
 Option 1 : Code "F"  
 DI1 : RUN/STOP  
 DI2 : AUTO/MAN  
 DI3 : Interlock release

• Remote setting input  
 When quick start code not specified  
 : 0 to 10V DC, The range will be same as input 1.

• CT input  
 CT1 assignment: Output 1 (OUT1)

• Output 3 (OUT3)  
 Current output (4 to 20mA),  
 Analog retransmission output  
 (Input 1 measured value)

• Communication  
 When quick start code not specified  
 : RKC standard communication (ANSI X3.28-1976).  
 The digit of the communication data depends on  
 the Input range code.

### Quick start code

#### FZ110/400/900

Quick start code	①	②	③	④	⑤	⑥	⑦	Specifications	
① Output allocation								See Output Allocation Code Table	
② Remote setting input		N						None When "Remote setting input" is not specified as an option, only "N: None" is selectable.	
		3						0 to 1V DC	
		4						0 to 5V DC	
		5						0 to 10V DC	
		6						1 to 5V DC	
		7						0 to 20mA DC	
		8						4 to 20mA DC	
		9						-5 to +5V DC	
		A						-10 to +10V DC	
	③ Event 1 ④ Event 2 ⑤ Event 3 ⑥ Event 4			N					None
			A					Deviation High	
			B					Deviation Low	
			C					Deviation High/Low	
			D					Band	
			E					Deviation High with Hold	
			F					Deviation Low with Hold	
			G					Deviation High/Low with Hold	
			H					Process High	
			J					Process Low	
			K					Process High with Hold	
			L					Process Low with Hold	
			Q					Deviation High with Alarm Re-hold	
			R					Deviation Low with Alarm Re-hold	
			T					Deviation High/Low with Re-Hold	
• The input allocation the event will be configured as "Input 1."				U					Band ( )
			V					Set value High	
			W					Set value Low	
			X					Deviation High/Low (*)	
			Y					Deviation High/Low with Alarm Hold (*)	
			Z					Deviation High/Low with Alarm Re-Hold (*)	
			1					MV value High	
			2					MV value Low	
			3					MV value High (Cool side)	
			4					MV value Low (Heat side)	
	⑦ Communication							N	None When "Communication" is not specified as an option, only "N: None" is selectable as the communication protocol.
								1	ANSI/RKC standard protocol
								2	MODBUS protocol
								3	PLC communication: MITSUBISHI MELSEC series special protocol

(\*1) Individual high and low settings

#### Output allocation code table

Code	OUT1	OUT2	DO1	DO2	DO3	DO4
1	Input 1 Control output (Heat side)/(Open side)	HBA1 HBA2	Event 1	Event 2	Event 3	Event 4
2	Input 1 Control output (Heat side)/(Open side)	HBA1 HBA2	Event 1	LBA1 LBA2	Event 3	Event 4
3	Input 1 Control output (Heat side)/(Open side)	FAIL	Event 1	HBA1 HBA2	Event 3	LBA1 LBA2
4	Input 1 Control output (Heat side)/(Open side)	HBA1 HBA2	Event 1	FAIL	Event 3	Event 4
5	Input 1 Control output (Heat side)/(Open side)	Event 1	LBA1 LBA2	HBA1 HBA2	Event 3	Event 4
6	Input 1 Control output (Heat side)/(Open side)	HBA1 HBA2	LBA1 LBA2	FAIL	Event 3	Event 4
7	Input 1 Control output (Heat side)/(Open side)	Event 1	LBA1 LBA2	FAIL	Event 3	Event 4
8	Input 1 Control output (Heat side)/(Open side)	Event 2 Event 4	Event 1 Event 3	HBA1 HBA2	LBA1 LBA2	FAIL
Note	When "Output 1 (OUT1)" is specified "N (None)", Allocation is None.	When "Output 2 (OUT2)" is specified "N (None)", Allocation is None.	[FZ110] When "Digital output" is specified "N (None)", Allocation is None.	[FZ110] When "Digital output" is specified "N (None)" or "1 (1 point)", Allocation is None. [FZ400/900] When "Digital output" is specified "N (None)", Allocation is None.	[FZ110] No allocation	[FZ110] No allocation [FZ400/900] When "Digital output" is specified "N (None)", Allocation is None.

\* If two or more items are allocated to the same output, the resultant output is OR.

#### OUT2 allocation

The output allocation depends on the Control action and the selection of Option 3.

Control Action	Option 3 (FZ400/900)	OUT2 allocation
PID control	None or Remote setting input	Output Allocation Code Table
Heat/Cool PID control or Position proportioning PID control	None or Remote setting input	Input 1 Control output Heat/Cool PID control: Cool-side Position proportioning PID control: Close-side
PID control	Measured input 2	Input 2 Control output (FZ400/900)

Loop break alarm (LBA) Initial setting code:

The output allocation has LBA output : 480

The output allocation has no LBA output: 0

# Rear Terminals

• Use a solderless terminal for screw size M3, width 5.8mm or less.

## FZ110



No	Description
1	AC 100-240V 24V DC 24V <sub>N</sub>
2	Power supply
3	Output 2 (OUT2) (1) Relay contact output (2) Voltage pulse/Current/Voltage/Transistor
4	Output 1 (OUT1) (1) Relay contact output (2) Voltage pulse/Current/Voltage/Transistor
5	Output 3 (OUT3) Voltage pulse/Current
6	CT Input
7	Digital input (DI1 to 3) Non voltage contact input
8	Digital output 1, 2 (DO 1, 2) Relay contact output
9	Measured input (1) Thermocouple (2) RTD (3) Voltage/Current

No	Description			
	Type 1	Type 2	Type 3	Type 4
13	Remote setpoint input Voltage/Current	Output 3 (OUT3) Voltage pulse/Current	CT Input	Digital input (DI1 to 3) Non voltage contact input
14	Digital input (DI1) Non voltage contact input	Digital input (DI1) Non voltage contact input	Digital input (DI1) Non voltage contact input	Digital input (DI1 to 3) Non voltage contact input
15	Communication RS-485	Communication RS-485	Communication RS-485	Communication RS-485
16	COM	COM	COM	COM
17	T/R(A)	T/R(A)	T/R(A)	T/R(A)
18	T/R(B)	T/R(B)	T/R(B)	T/R(B)

No	Description
7	Digital output 1, 2 (DO 1, 2) Relay contact output
8	Digital output 2 (DO 2) Relay contact output
9	Digital output 3 (DO 3) Relay contact output
10	Digital output 4 (DO 4) Relay contact output
11	Measured input (1) Thermocouple (2) RTD (3) Voltage/Current

CT : Current transformer for heater break alarm

## FZ900



No	Description
1	AC 100-240V 24V DC 24V <sub>N</sub>
2	Power supply
3	Output 2 (OUT2) (1) Relay contact output (2) Voltage pulse/Current/Voltage/Transistor
4	Output 1 (OUT1) (1) Relay contact output (2) Voltage pulse/Current/Voltage/Transistor
5	Output 3 (OUT3) Voltage pulse/Current
6	CT Input
7	Digital input (DI1 to 6) Non voltage contact input
8	Digital output 1 (DO 1) Relay contact output
9	Digital output 2 (DO 2) Relay contact output
10	Digital output 3 (DO 3) Relay contact output
11	Digital output 4 (DO 4) Relay contact output
12	Measured input 1 (1) Thermocouple (2) RTD (3) Voltage/Current

No	Description	
	Type 1	Type 2
25	Output 3 (OUT3) Voltage pulse/Current	Output 3 (OUT3) Voltage pulse/Current
26	Digital input (DI1 to 6) Non voltage contact input	Digital input (DI1 to 6) Non voltage contact input
27	COM	COM
28	DI 1	DI 1
29	DI 2	DI 2
30	DI 3	DI 3
31	DI 4	DI 4
32	DI 5	DI 5
33	DI 6	DI 6
34	Communication RS-485	Communication RS-485
35	T/R(A)	T/A
36	T/R(B)	T/B

No	Description
13	Digital output 2 (DO 2) Relay contact output
14	Digital output 3 (DO 3) Relay contact output
15	Digital output 4 (DO 4) Relay contact output
16	Measured input 2 (Remote setting input) (1) Thermocouple (2) RTD (3) Voltage/Current

## FZ400



No	Description
1	AC 100-240V 24V DC 24V <sub>N</sub>
2	Power supply
3	Output 2 (OUT2) (1) Relay contact output (2) Voltage pulse/Current/Voltage/Transistor
4	Output 1 (OUT1) (1) Relay contact output (2) Voltage pulse/Current/Voltage/Transistor
5	Output 3 (OUT3) Voltage pulse/Current
6	CT Input
7	Digital input (DI1 to 4) Non voltage contact input
8	Digital output 1 (DO 1) Relay contact output
9	Digital output 2 (DO 2) Relay contact output
10	Digital output 3 (DO 3) Relay contact output
11	Digital output 4 (DO 4) Relay contact output
12	Measured input 1 (1) Thermocouple (2) RTD (3) Voltage/Current

## External Dimensions

Unit:mm

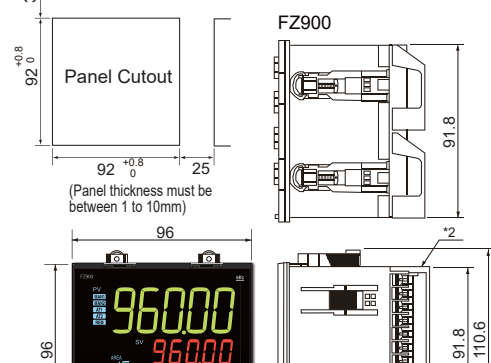
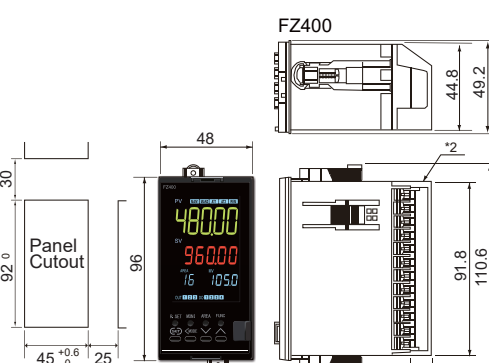
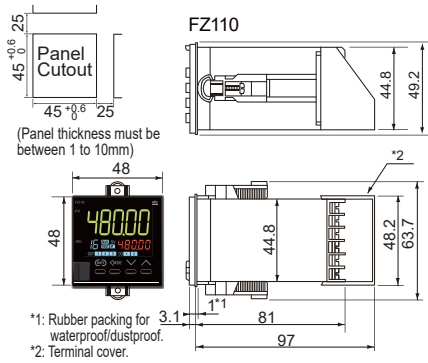

### < Close horizontal mounting > • Up to 6 units

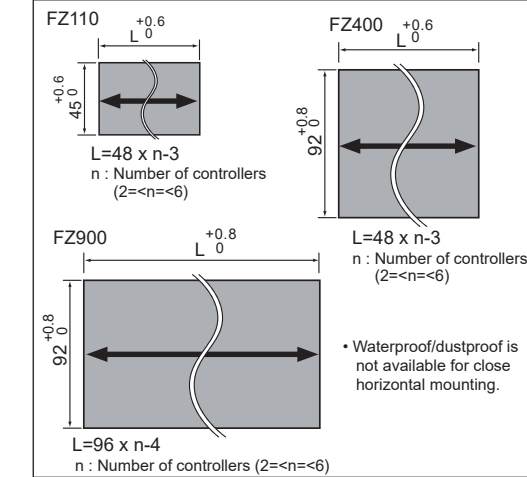

## Accessories (Sold separately)

### Terminal Cover

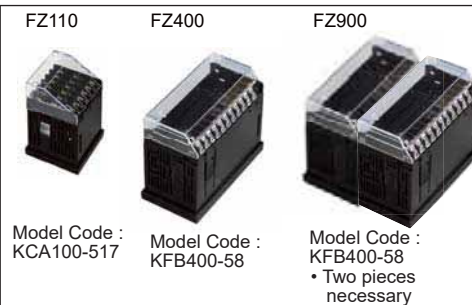

### Front Cover

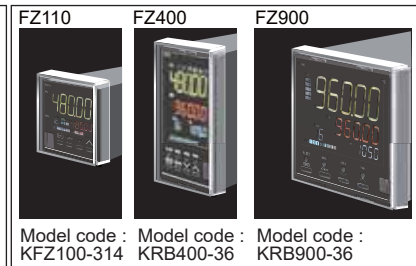

- Before operating this product, read the instruction manual carefully to avoid incorrect operation.
- This product is intended for use with industrial machines, test and measuring equipment. It is not designed for use with medical equipment.
- If it is possible that an accident may occur as a result of the failure of the product or some other abnormality, an appropriate independent protection device must be installed.

### Caution for the export trade

All transactions must comply with laws, regulations, and treaties.

### Caution for imitated products

As products imitating our product now appear on the market, be careful that you don't purchase these imitated products. We will not warrant such products nor bear the responsibility for any damage and/or accident caused by their use.

**RKC** RKC INSTRUMENT INC.  
(RIKA KOGYO CO.,LTD)

HEAD OFFICE : 16-6, KUGAHARA 5 CHOME OHTA-KU TOKYO 146-8515 JAPAN  
PHONE : 03-3751-9799 (+81 3 3751 9799)  
Email : info@rkinst.co.jp  
http://www.rkinst.com/