

Lantern type sight glass

Model : S400 series

Spec. sheet no. SD04-01

Description

Lantern sight glass is used for low pressure, and can check the state of fluid flow from any direction.

Model : S400

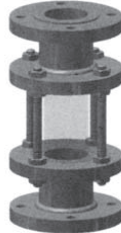

Connections

Flanged end

Max. pressure

0.7 MPa

Max. temperature

100 °C

Glass

Tempered

Body material

Carbon steel (Steel plate)

304SS (Stainless steel plate)

316SS (Stainless steel plate)

Dimension

Size A(″)	L	E
15 (½)	220	80
20 (¾)	220	80
25 (1)	220	80
32 (1¼)	220	80
40 (1½)	220	80
50 (2)	240	80
65 (2½)	240	80
80 (3)	240	80
100 (4)	260	80
125 (5)	280	80
150 (6)	280	80
200 (8)	280	80

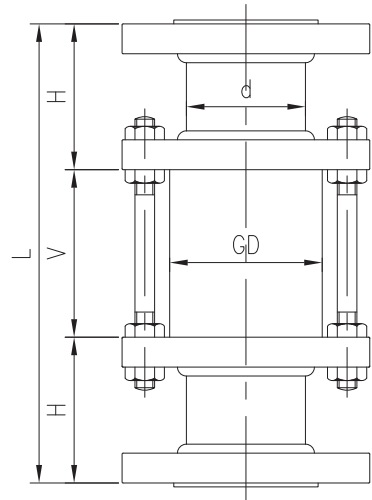

Model : S410



Connections

Flanged end

Max. pressure

0.7 MPa

Max. temperature

100 °C

Glass

Tempered

Body material

Carbon steel (Steel plate)

304SS (Stainless steel plate)

316SS (Stainless steel plate)

Dimension

Size	L	V	GD	D	G
15	150	80	35	15	40
20	150	80	40	20	50
25	150	80	45	25	60
40	150	80	60	40	75
50	150	80	70	50	90
65	150	80	85	65	110
80	150	80	100	80	120
100	150	80	125	100	145
125	150	80	150	125	175
150	150	80	180	150	210
200	150	80	230	200	260

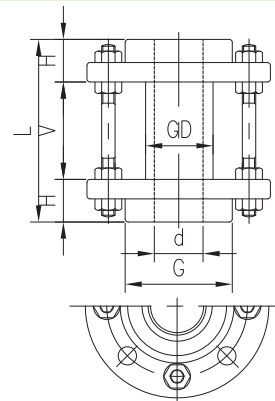

1. Base model

S400	Lantern type (Long) sight glass
S410	Lantern type (Short) sight glass

2. Line size

JIS	mm	ANSI	inch	DIN	mm
J015	15A	A001	½B	D015	15A
J020	20A	A002	¾B	D020	20A
J025	25A	A003	1B	D025	25A
J040	40A	A004	1½B	D040	40A
J050	50A	A005	2B	D050	50A
J065	65A	A006	2½B	D065	65A
J080	80A	A007	3B	D080	80A
J100	100A	A008	4B	D100	100A
J125	125A	A009	5B	D125	125A
J150	150A	A010	6B	D150	150A
J200	200A	A011	8B	D200	200A
		XXXX	Other		

3. Glass material

T	Tempered
O	Other

4. Flange rating code

JIS		ANSI		PN	
J010	JIS 10K	A010	ANSI 150 Lb	P010	10 bar
J020	JIS 20K	A020	ANSI 300 Lb	P016	16 bar
XXXX	None				

5. Gaskets material

N	Non-Asbestos
T	Teflon
O	Other

6. Body material

C	Carbon steel (A216 WCB)
4	304SS (A351 CF8)
6	316SS (A351 CF8M)
O	Other

1	2	3	4	5	6	
S400	J100	T	A010	N	6	Sample ordering code