

General purpose pressure gauge

Model : P140 series

Spec. sheet no. PD01-05

Service intended

P140 series are designed to withstand a severe weather conditions and the rust under chemical or petrochemical circumstances allowing continuous exposure to the atmosphere.



Nominal diameter

60 and 100 mm

Accuracy

60 and 100 mm : ± 1.5 % of full scale

Scale range (MPa, kPa, bar)

60 mm : -0.1 ~ 0 to 0 ~ 25 MPa

100 mm : -0.1 ~ 0 to 0 - 35 MPa

Working pressure

Steady : 75 % of full scale

Over range protection : 130 % of full scale

Working temperature

Ambient : -20 ~ 60 °C

Fluid : Max. 60 °C

Temperature effect

Accuracy at temperature above and below the reference temperature (20 °C) will be effected by approximately ± 0.4 % per 10 °C of full scale



Standard features

Pressure connection

Brass

Movement

Brass

Element

C type bourdon tube

60 and 100 mm : ≤ 10 MPa : Brass

> 10 MPa : 316SS

Dial

White aluminium with black graduations

Case

Polycarbonate

Pointer

Black painted aluminium alloy

Cover

Polycarbonate

Process connection

60 mm : $\frac{1}{4}$ " PT, NPT and PF

100 mm : $\frac{3}{8}$ " PT, NPT and PF

1. Base model

P140 General purpose pressure gauge

2. Nominal diameter (mm)

- 2 60
- 4 100

3. Type of mounting

- A Bottom connection, direct

4. Accuracy

- 4 ± 1.5 % of full scale

5. Process connection

- C $\frac{1}{4}$ "
- D $\frac{3}{8}$ " only available with diameter 100 mm

6. Connection type

- B PF
- C PT
- D NPT
- Z Other

7. Unit

- H bar
- I MPa
- J kPa

8. Range

XXX Refer to pressure unit and range table

9. Dial color

- 1 2 colors
- 5 3 colors

10. Option

- 0 None
- 1 Accessories

1	2	3	4	5	6	7	8	9	10	Sample ordering code
P140	2	A	4	C	D	H	XXX	5	0	

P140 : Type of mounting

Code A

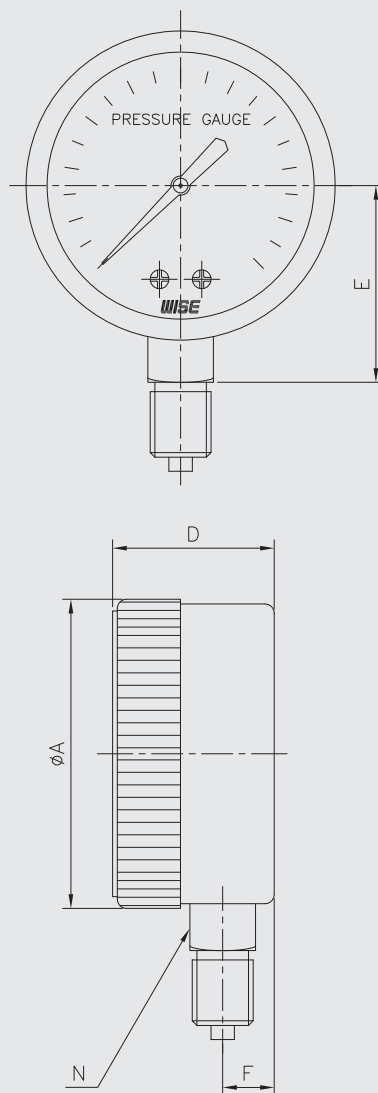

Dimensions (mm)

Dial size	Available code	A	D±2	E±2	F±1	N
60	A	70	31.5	42	11.5	14
100	A	110	35	116.5	13.5	17

Pressure unit and range table

Range and code	Unit and code			Nominal diameter	
	H : bar	I : MPa	J : kPa	60 mm	100 mm
026	-1 ~ 0	-0.1 ~ 0	-100 ~ 0	O	O
041	0 ~ 1	0 ~ 0.1	0 ~ 100	O	O
042	0 ~ 2	0 ~ 0.2	0 ~ 200	O	O
043	0 ~ 3	0 ~ 0.3	0 ~ 300	O	O
044	0 ~ 4	0 ~ 0.4	0 ~ 400	O	O
045	0 ~ 6	0 ~ 0.6	0 ~ 600	O	O
047	0 ~ 10	0 ~ 1	0 ~ 1,000	O	O
050	0 ~ 15	0 ~ 1.5	X	O	O
051	0 ~ 20	0 ~ 2	X	O	O
052	0 ~ 25	0 ~ 2.5	X	O	O
054	0 ~ 35	0 ~ 3.5	X	O	O
055	0 ~ 50	0 ~ 5	X	O	O
057	0 ~ 70	0 ~ 7	X	O	O
058	0 ~ 100	0 ~ 10	X	O	O
059	0 ~ 150	0 ~ 15	X	O	O
062	0 ~ 250	0 ~ 25	X	O	O
064	0 ~ 350	0 ~ 35	X	X	O
027	-1 ~ 1	-0.1 ~ 0.1	-100 ~ 100	O	O
028	-1 ~ 2	-0.1 ~ 0.2	-100 ~ 200	O	O
029	-1 ~ 3	-0.1 ~ 0.3	-100 ~ 300	O	O
030	-1 ~ 4	-0.1 ~ 0.4	-100 ~ 400	O	O
031	-1 ~ 6	-0.1 ~ 0.6	-100 ~ 600	O	O
032	-1 ~ 10	-0.1 ~ 1	-100 ~ 1,000	O	O
033	-1 ~ 15	-0.1 ~ 1.5	-100 ~ 1.5 MPa	O	O
034	-1 ~ 20	-0.1 ~ 2	-100 ~ 2 MPa	O	O

O : Available X : Not available