

Differential pressure gauge with inductive contact type

Model: P690 series

Spec. sheet no. PD06-07

Service intended

P690 differential pressure gauge series are designed to measure differential pressure from 25 kPa to 2.0 MPa at Max. working pressure up to 10 MPa and have inductive contact. P690 series are designed to control alarm for differential pressure, providing the right time to replace air and sludge filter during the process.



Nominal diameter

160 mm

Accuracy

±1.6 % of full scale

Scale range (MPa, kPa, bar, mbar)

0 ~ 25 kPa to 0 ~ 0.25 MPa

0 ~ 0.4 MPa to 0 ~ 2 MPa

Max. working pressure (Static pressure)

Max. 10 MPa

Working temperature

Ambient : -20 ~ 65 °C

-40 ~ 65 °C (With silicone filling)

Fluid : Max. 100 °C

Degree of protection

EN60529/IEC529/IP65

Temperature effect

Accuracy at temperature above and below the reference temperature (20 °C) will be effected by approximately ±0.5 % per 10 °C of full scale



Standard features

Pressure connection

Stainless steel (316SS)

Element

Bellows

Stainless steel (316L SS)

Case and cover

Stainless steel (304SS)

Bayonet type

Dial

White aluminium with black graduations

Window

Polycarbonate

Pointer

Black painted aluminium alloy

Contact

Inductive contact

Conduit connection

M20 x 1.5P

Process connection

¼" NPT(F)

½" NPT(F) at 3-way and 5-way manifold valve

Standard accessories

Mounting bracket for 2" pipe

mounting with silver gray finished steel

Certificates

NEPSI Ex ia IIC T6 Ga

Tamb = -25 ~ 56 °C

Option

■ Remote seal

■ ½" (N)PT female conduit connection

■ ¾" (N)PT female conduit connection

■ Mounting bracket with 316SS for 2" pipe mounting

■ 3-way manifold valve (316SS)

■ 5-way manifold valve (316SS)

■ 3-way manifold valve (Monel)

■ 5-way manifold valve (Monel)

WISE[®]

| P690_01

1. Base model

P691 Differential pressure gauge with inductive contact type
(0 ~ 25 kPa to 0 ~ 0.25 MPa)

P692 Differential pressure gauge with inductive contact type
(0 ~ 0.4 MPa to 0 ~ 2.0 MPa)

2. Nominal diameter (mm)

6 160

3. Type of mounting

D Bottom connection, mounting bracket for 2" pipe

4. Contact function

X Refer to contact function table

5. Process connection

C ¼" NPT(F)

E ½" NPT(F), only at 3-way and 5-way manifold valve

6. Mounting bracket

D Standard bracket

E 304SS mounting bracket

F 316SS mounting bracket

W Wall mounting bracket (316SS)

7. Unit

H bar

I MPa

J kPa

S mbar

8. Range

XXX Refer to pressure unit and range table

9. Dial color

3 2 colors

10. Option

0 None

1 Manifold valve

6 Silicone filling

7 Manifold valve and silicone filling

8 ½" or ¾" NPT(F) conduit connection

1	2	3	4	5	6	7	8	9	10
P691	6	D	X	C	D	H	XXX	1	0

Sample
ordering code

P69X : Type of mounting

Code:(D) P690

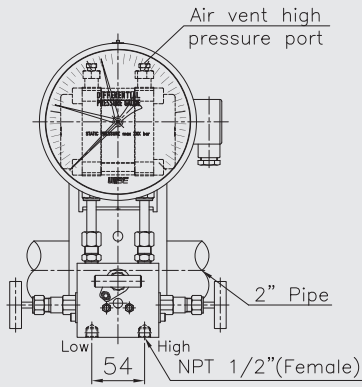

Code:(D) P690(Remote seal)

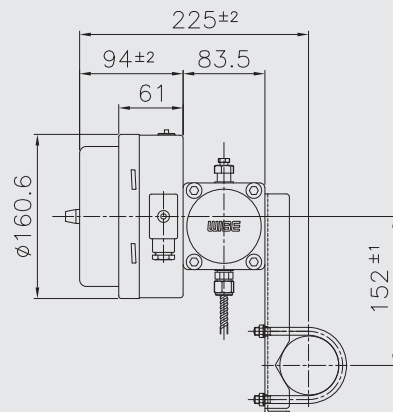
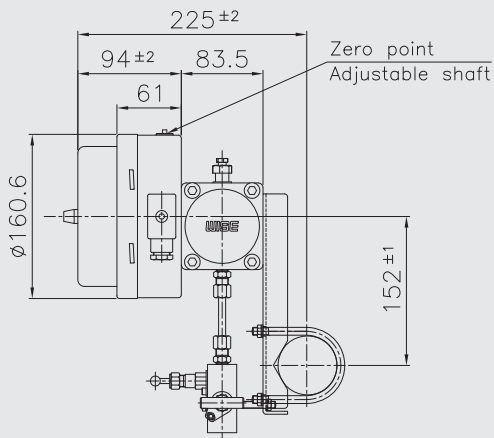
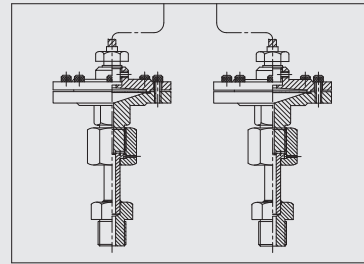
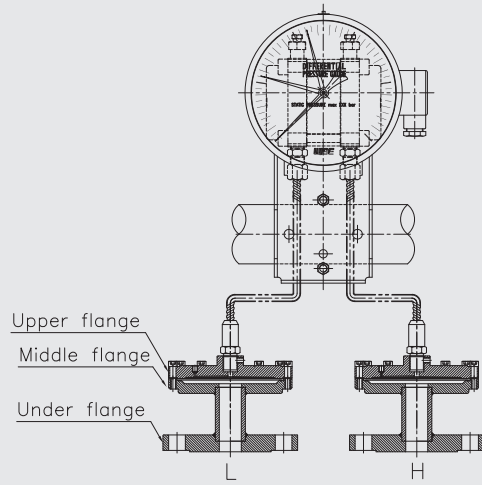

Contact function table

Code	Wiring scheme	Contact function		Wiebrock code no.	Slot sensor	
		1 st contact	2 nd contact			
Single contact						
1	Control vane inside the slot sensor - Contact make (Normal open)				I-1	SJ3.5N for 160 mm
3	Control vane out of the slot sensor - Contact break (Normal open)				I-2	SJ3.5N for 160 mm
Double contact						
4	1 st and 2 nd Control vane inside the slot sensor - 1 st and 2 nd Contact make	1 st 1(-) / 3(+) 2 nd 4(-) / 6(+) 			I-11	SJ3.5N for 160 mm
6	1 st Control vane inside and 2 nd control vane out of the slot sensor - 1 st Contact make 2 nd Contact break	1 st 1(-) / 3(+) 2 nd 4(-) / 6(-) 			I-12	SJ3.5N for 160 mm Failsafe contact
2	1 st Control vane out of the vane and 2 nd control vane inside of the vane - 1 st Contact break 2 nd Contact make	1 st 1(-) / 3(+) 2 nd 4(-) / 6(+) 			I-21	SJ3.5N for 160 mm
5	1 st and 2 nd Control vane out of the slot sensor - 1 st and 2 nd Contact break	1 st 1(-) / 3(+) 2 nd 4(-) / 6(+) 			I-22	SJ3.5N for 160 mm

Terminal block arrangement

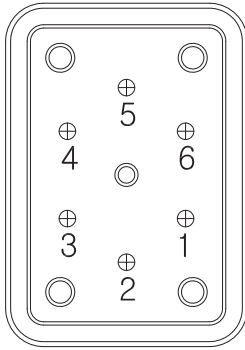

1. High alarm (I-1)

- ① Normal open (+)
- ③ Common (-)
- ⑤ Ground

2. High and low alarm (I-21)

Low alarm

- ① Normal close (+)
- ③ Common (-)
- ⑤ Ground

High alarm

- ④ Normal open (+)
- ⑥ Common (-)

3. Low alarm (I-2)

- ① Normal close (+)
- ③ Common (-)
- ⑤ Ground

4. Two high alarm (I-11)

No.1 High alarm

- ① Normal open (+)
- ③ Common (-)
- ⑤ Ground

No.2 High alarm

- ④ Normal open (+)
- ⑥ Common (-)

5. Two low alarm (I-22)

No.2 Low alarm

- ① Normal close (+)
- ③ Common (-)
- ⑤ Ground

No.1 Low alarm

- ④ Normal close (+)
- ⑥ Common (-)

6. Failsafe high and low alarm (I-12)

High alarm

- ① Normal open (+)
- ③ Common (-)
- ⑤ Ground

Low alarm

- ④ Normal close (+)
- ⑥ Common (-)

Inductive alarm sensor model P690 series

Service intended

WISE inductive contacts are certified for use in hazardous areas of zone 1 and zone 2.

Power supply must be made by means of a power source certified intrinsically safe such as Pepper and Fucus model KFA6-SR2-EX1.W

Inductive contact are also recommended for critical non-hazardous applications where an utmost of failsafe heavy duty operation is required.

In combination with liquid filled instruments these contacts are particularly suited for process control circuits in the chemical and petroleum industry.

Operating principle

At the heart of the WISE inductive contact system is a noncontact sensor attached to an pressure gauge.

Both sensor and gauge are adjustable over the full length of the scale. Contact actuation is achieved by means of a Control vane linked to the pointer of the gauge.

The Control vane affects the electric field of the sensor when the instruments pointer overlaps with the contacts indicator.

Contact actuation is made without any mechanical force that would affect accuracy of the gauge.

The scheme below reflects the operating principle in comparison with conventional mechanical contacts :

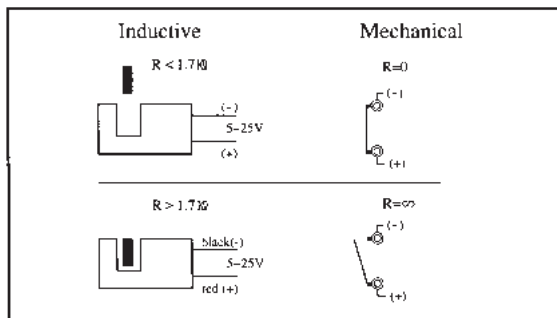

Dimensions of the basic instrument and provisions for contacts adjustment are identical to contacts of model P500.

Operating temperature: -25 °c... +70 °c

Used sensor (slot-type initiator):

Type SJ of the company Pepper and Fuchs, EC-Type

Examination certificate PTB 00 ATEX 2081

Advantage of the WISE inductive system

- Long Service life by means of non-contact sensor
- Very little effect on gauge accuracy
- No reduced rating with liquid filled gauges
- Fully suitable in corrosive or hazardous atmosphere
- Ex-approved for service in hazardous area of Zone 1 or 2

Components of the WISE inductive contact system

Operation of the inductive contact system requires an appropriate electronic power supply and control unit

The Safety Barrier consists of

- Line transformer
- Amplifier circuit
- Relay to switch external circuit

The isolated line transformer provides for power supply whereas the amplifier conditions the signal of the inductive sensor to energise the output relay

Available are two versions of control units

- Ex-approved intrinsic safety
- Standard for non-intrinsically safe version (optional)

Safety barrier for inductive contacts
Ex-certified versions
Safety barrier model KFA6-SR2-Ex1.W

- Intended for instruments having one inductive contact incorporated
- Alarm circuit certified intrinsically safe [EEx a] IIC
- Provides 1 SPDT relay output contact
- LED indicating circuit status (green), relay output (yellow) and lead breakage (red)
- Case surface mounting type Form A

Note

Directions of action adjustable by sliding switch S1 :
 Open circuit causes alarm : Switch S1 in position I
 Closed circuit causes alarm : Switch S1 in position II

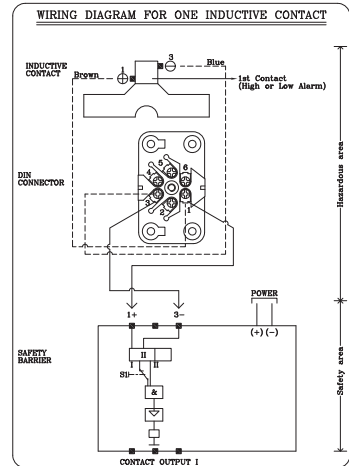

SAFETY BARRIER MODEL	Contact Output I (High or Low Alarm)	POWER
KFA5-SR2-Ex1.W(115V, AC)	7(COMMON) 8(OPEN) 9(CLOSE)	14(+) 15(-)
KFA6-SR2-Ex1.W(230V, AC)		
KFD2-SR2-Ex1.W(24V, DC)		

Safety barrier model KFA6-SR2-Ex2.W

- Intended for 1 instrument having two inductive contacts, or two instruments having one inductive contact incorporated
- Alarm circuit certified intrinsically safe [EEx a] IIC to EN 50 227 and NAMUR
- Provides 2 SPDT relay output contacts
- LED indicating circuit status (green), 2 x relay output (yellow) and 2 x lead breakage (red)
- Case surface mounting type Form B

Note

Directions of action adjustable by sliding switch S1 and S2 :
 Open circuit causes alarm : Switch S1 and S2 in position I
 Closed circuit causes alarm : Switch S1 and S2 in position II

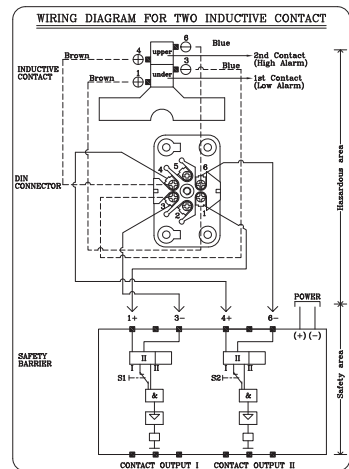

SAFETY BARRIER MODEL	Contact Output I (Low Alarm)	Contact Output II (High Alarm)	POWER
KFA5-SR2-Ex2.W(115V, AC)	7(COMMON) 8(OPEN) 9(CLOSE)	10(COMMON) 11(OPEN) 12(CLOSE)	14(+) 15(-)
KFA6-SR2-Ex2.W(230V, AC)			
KFD2-SR2-Ex2.W(24V, DC)			

Dimensions of safety barrier for inductive contact

Model : KFA6-SR2-Ex1.W

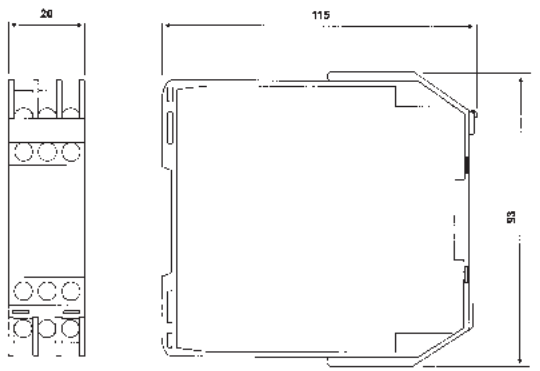

Form A

Model : KFA6-SR2-Ex2.W

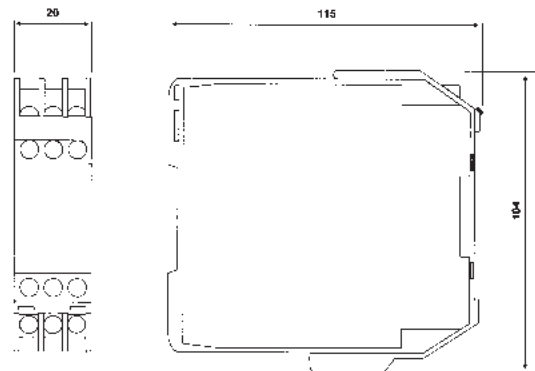

Form B

Specifications for safety barrier	Model KFA6-SR2-Ex1.W	Model KFA6-SR2-Ex2.W
Power supply		
Line voltage	AC 230 V $\pm 10\%$, 45...65 Hz	AC 230 V $\pm 10\%$, 45...65 Hz
Consumption	≤ 1 W	≤ 1.3 W
Input		
No. of contacts	1	2
Voltage (reactive)	DC 8 V	DC 8 V
Maximum current	8 mA	8 mA
Contact actuation	$1.2 \text{ mA} \leq I_s \leq 2.1 \text{ mA}$	$1.2 \text{ mA} \leq I_s \leq 2.1 \text{ mA}$
Contact hysteresis	Ca. 0.2 mA	Ca. 0.2 mA
Control line impedance	100 Ω	100 Ω
Ex-IS data (as PTB-certified)		
	PTB 00 ATEX 2081	PTB 00 ATEX 2081
Voltage	$U_o \leq \text{DC } 10.6 \text{ V}$	$U_o \leq \text{DC } 10.6 \text{ V}$
Current	$I_o \leq 19.1 \text{ mA}$	$I_o \leq 19.1 \text{ mA}$
Power rating	$P_o \leq 51 \text{ mW}$	$P_o \leq 51 \text{ mW}$
IS-classification	[EEx ia] IIC	[EEx ia] IIC
Ext. capacitance	2.9 μF	2.9 μF
Ext. inductance	100 mH	100 mH
Output		
Relay contacts	1 SPDT	1 SPDT
Contact rating AC	253 V, 2 A, 500 VA, $\cos\phi > 0.7$	253 V, 2 A, 500 VA, $\cos\phi > 0.7$
Contact rating DC	4 V, 2 A, ohmic	4 V, 2 A, ohmic
Delay making circuit	Approx. 20 ms	Approx. 20 ms
Delay breaking circuit	Approx. 20 ms	Approx. 20 ms
Max. on-off frequency	≤ 10 Hz	≤ 10 Hz
Operating conditions		
Min. temperature	-20 $^{\circ}\text{C}$	-20 $^{\circ}\text{C}$
Max. temperature	+60 $^{\circ}\text{C}$	+60 $^{\circ}\text{C}$
Max. humidity	Max. 75 % (IEC 60529:2001)	Max. 75 % (IEC 60529:2001)
Protection degree	IP 20 (EN 60 529 / IEC 529)	IP 20 (EN 60 529 / IEC 529)
Enclosure		
Style	Surface mounting	Surface mounting
Dimensions per drawing	Form A	Form B
Mounting	on 35 mm DIN mounting rail acc. to EN 60715-2001	
Weight	Approx. 0.15 kg	Approx. 0.15 kg

Pressure unit and range table

Range and code	Unit and code				Model	Max. static pressure
	J : kPa	S : mbar	H : bar	I : MPa		
118	0 ~ 25	0 ~ 250	X	X	P691	10 MPa
121	0 ~ 40	0 ~ 400	X	X		
125	0 ~ 60	0 ~ 600	X	X		
041	0 ~ 100	X	0 ~ 1	0 ~ 0.1		
133	0 ~ 160	X	0 ~ 1.6	0 ~ 0.16		
042	0 ~ 200	X	0 ~ 2	0 ~ 0.2		
134	0 ~ 250	X	0 ~ 2.5	0 ~ 0.25		
044	0 ~ 400	X	0 ~ 4	0 ~ 0.4	P692	
045	0 ~ 600	X	0 ~ 6	0 ~ 0.6		
047	0 ~ 1,000	X	0 ~ 10	0 ~ 1		
143	X	X	0 ~ 16	0 ~ 1.6		
051	X	X	0 ~ 20	0 ~ 2		

X : Not available