



## OPTIFLUX 1000 **Technical Datasheet**

Electromagnetic flow sensor in sandwich design

- Lightweight and compact
- Excellent price performance ratio
- Quick and easy to install



The documentation is only complete when used in combination with the relevant documentation for the signal converter.

1 Product features	3
1.1 Cost efficient and reliable flow sensor .....	3
1.2 Options .....	5
1.3 Measuring principle.....	6
2 Technical data	7
2.1 Technical data.....	7
2.2 Measuring accuracy .....	11
2.3 Dimensions and weights .....	12
3 Installation	15
3.1 Intended use .....	15
3.2 General notes on installation .....	15
3.2.1 Vibration .....	15
3.2.2 Magnetic field.....	15
3.3 Installation conditions .....	16
3.3.1 Inlet and outlet .....	16
3.3.2 Bends in 2 or 3 dimensions.....	16
3.3.3 T-section .....	16
3.3.4 Bends .....	17
3.3.5 Open feed or discharge.....	17
3.3.6 Flange deviation .....	18
3.3.7 Pump .....	18
3.3.8 Control valve .....	18
3.3.9 Air venting and vacuum forces .....	19
3.3.10 Mounting position.....	19
4 Electrical connections	20
4.1 Safety instructions.....	20
4.2 Grounding .....	20
4.3 Virtual reference for IFC 300 .....	21
5 Notes	22

## 1.1 Cost efficient and reliable flow sensor

The flangeless **OPTIFLUX 1000** electromagnetic flow sensor is compact and lightweight. The design is robust with the highly resistant, reinforced PFA liner and Hastelloy<sup>®</sup> electrodes. This offers an excellent chemical resistance.

The device is a cost-efficient and reliable solution for a wide range of applications. For industries varying from water and wastewater, agriculture, utilities and from fire-fighting to machine building.



- ① Sandwich design
- ② PFA liner
- ③ Hastelloy<sup>®</sup> electrodes

**Highlights**

- Sandwich (wafer) design
- Lightweight and compact for easy handling and space saving installation
- Affordable price
- Excellent chemical resistance
- Bi-directional measurements
- No pressure loss
- Insensitive to vibrations
- No internal moving parts, no maintenance

**Industries**

- Machine building
- Energy, HVAC
- Water & wastewater
- Agriculture
- Process industries

**Applications**

- Mixing, batching and dosing systems, filtration systems, pump control
- Water flow monitoring
- Water circulation and treatment systems
- Fire-fighting systems, foam mixing, control of sprinkler systems
- Heat transfer and cooling systems
- Water including; raw water, process water, wastewater, salt water, heated and cooled water
- Mud, slurry, sludge, manure

## 1.2 Options



The **OPTIFLUX 1000** flow sensor is available in a diameter range from DN10 up to DN150 (3/8...6"). The compact flangeless flow sensor meets all applicable process connections: EN 1092, DIN, ANSI and JIS.



### Signal converters

The **OPTIFLUX 1000** flow sensor is compatible with the IFC 050, IFC 100 and IFC 300 signal converter.

The flangeless flowmeter is suitable for compact and remote (field) mounting.

### 1.3 Measuring principle

An electrically conductive fluid flows inside an electrically insulated pipe through a magnetic field. This magnetic field is generated by a current, flowing through a pair of field coils.

Inside of the fluid, a voltage  $U$  is generated:

$$U = v \cdot k \cdot B \cdot D$$

in which:

$v$  = mean flow velocity

$k$  = factor correcting for geometry

$B$  = magnetic field strength

$D$  = inner diameter of flowmeter

The signal voltage  $U$  is picked off by electrodes and is proportional to the mean flow velocity  $v$  and thus the flow rate  $Q$ . A signal converter is used to amplify the signal voltage, filter it and convert it into signals for totalizing, recording and output processing.

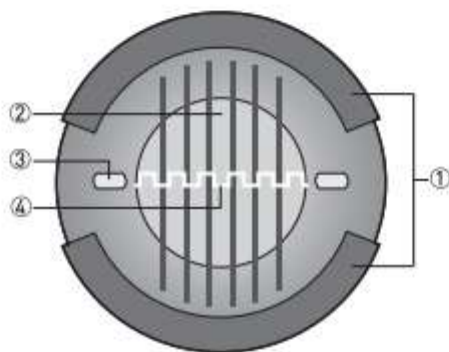

Figure 1-1: Measuring principle

- ① Field coils
- ② Magnetic field
- ③ Electrodes
- ④ Induced voltage [proportional to flow velocity]

## 2.1 Technical data

- *The following data is provided for general applications. If you require data that is more relevant to your specific application, please contact us or your local sales office.*
- *Additional information (certificates, special tools, software,...) and complete product documentation can be downloaded free of charge from the website (Downloadcenter).*

### Measuring system

Measuring principle	Faraday's law of induction
Application range	Electrically conductive fluids
<b>Measured value</b>	
Primary measured value	Flow velocity
Secondary measured value	Volume flow

### Design

Features	Sandwich design
	PFA liner and Hastelloy® electrodes
	Light weight and compact
Modular construction	The measurement system consists of a flow sensor and a signal converter. It is available as compact and as separate version. Additional information can be found in the documentation of the signal converter.
Compact version	With signal converter IFC 050: OPTIFLUX 1050 C
	With signal converter IFC 100: OPTIFLUX 1100 C
	With signal converter IFC 300: OPTIFLUX 1300 C
Remote version	In wall (W) mount version with signal converter IFC 050: OPTIFLUX 1050 W
	In wall (W) mount version with signal converter IFC 100: OPTIFLUX 1100 W
	In field (F), wall (W) or rack (R) mount version with signal converter IFC 300: OPTIFLUX 1300 F, W or R
Nominal diameter	DN10...150 / 3/8...6"

### Measuring accuracy

Maximum measuring error	IFC 050: down to 0.5% of the measured value $\pm 1$ mm/s
	IFC 100: down to 0.4% of the measured value $\pm 1$ mm/s
	IFC 300: down to 0.3% of the measured value $\pm 2$ mm/s
	The maximum measuring error depends on the installation conditions.
	For detailed information refer to <i>Measuring accuracy</i> on page 11.
Repeatability	$\pm 0.1\%$ of MV, minimum 1 mm/s
Calibration	2 point calibration by direct volume comparison <b>Optional:</b> special calibration on request.

## Operating conditions

<b>Temperature</b>	
Process temperature	-25...+120°C / -13...+248°F
Ambient temperature	-25...+65°C / -13...+149°F
Protect electronics against self-heating at ambient temperatures above +55°C / +131°F	
Storage temperature	-50...+70°C / -58...+158°F
<b>Measuring range</b>	-12...+12 m/s / -40...+40 ft/s
<b>Pressure</b>	
Ambient pressure	Atmospheric
Operating pressure	Up to 16 bar / 230 psi
Vacuum load	0 mbar / psi absolute
Pressure loss	Negligible
Pressure ranges for secondary containment	Pressure resistant up to 40 bar / 580 psi
	Burst pressure up to approx. 160 bar / 2320 psi
<b>Chemical properties</b>	
Physical condition	Electrically conductive liquids
Electrical conductivity	Standard: $\geq 5 \mu\text{S/cm}$
	Demineralised water: $\geq 20 \mu\text{S/cm}$
Permissible gas content (volume)	IFC 050: $\leq 3\%$
	IFC 100: $\leq 3\%$
	IFC 300: $\leq 5\%$
Permissible solid content (volume)	IFC 050: $\leq 10\%$
	IFC 100: $\leq 10\%$
	IFC 300: $\leq 70\%$

## Installation conditions

Installation	Assure that the flow sensor is always fully filled.
	For detailed information refer to <i>Installation</i> on page 15.
Flow direction	Forward and reverse
	Arrow on flow sensor indicates positive flow direction.
Inlet run	$\geq 5 \text{ DN}$
Outlet run	$\geq 2 \text{ DN}$
Dimensions and weights	For detailed information refer to <i>Dimensions and weights</i> on page 12.



### Materials

Flow sensor housing	DN10...40 / 3/8...1½": malleable iron [GTW-S-38-12]
	DN50...150 / 2...6": sheet steel
Measuring tube	Austenitic stainless steel
Liner	PFA
Protective coating	On exterior of the meter: housing, signal converter (compact version) and/or connection box (field version)
	Standard coating
Connection box	Only for remote versions
	Standard: die-cast aluminium
	Option: stainless steel
Measuring electrodes	Hastelloy® C
Grounding rings	Standard: for DN10...15 / 3/8...1½": (integrated in flow sensor construction)
	Optional: for DN25...150 / 1...4"
	Stainless steel 316L [1.4404]
	Grounding rings can be omitted with virtual reference option for the signal converter IFC 300.
Mounting material	DN40...150 / 1½...6"
	Standard: rubber centering sleeves
	Option: galvanised steel or stainless steel stud bolts and nuts

### Process connections

Counter flanges	
EN 1092-1	DN10...80: PN16 or PN40 DN100...150: PN16 (standard), PN40 on request
ASME	3/8...6": 150 lb / RF 3/8...4": 300 lb / RF
JIS	DN10...100: JIS 20K [≤ 16 bar] / DN150: JIS 10K [≤ 10 bar]

### Electrical connections

	For full detail refer to the relevant documentation of the signal converter.
Signal cable (for remote systems only)	
Type A (DS)	<b>In combination with the signal converter IFC 050, IFC 100 and IFC 300</b> Standard cable, double shielded. Max. length: 600 m / 1968 ft [depends on electrical conductivity and flow sensor].
Type B (BTS)	<b>Only in combination with the signal converter IFC 300</b> Optional cable, triple shielded. Max. length: 600 m / 1968 ft [depends on electrical conductivity and flow sensor].
I/O	For full details of I/O options, including data streams and protocols, see technical datasheet of the relevant signal converter.

## Approvals and certifications

<b>CE</b>	
This device fulfils the statutory requirements of the EC directives. The manufacturer certifies successful testing of the product by applying the CE mark.	
	For full information of the EU directive & standards and the approved certifications; please refer to the CE declaration or the website of the manufacturer.
<b>Hazardous areas</b>	
FM	<b>In combination with signal converter IFC 300C &amp; F</b>
	Class I, Div. 2, Groups A, B, C and D
	Class II, Div. 2, Groups F and G
	Class III, Div. 2
CSA	<b>In combination with signal converter IFC 300C &amp; F</b>
	Class I, Div. 2, Groups A, B, C and D
	Class II, Div. 2, Groups F and G
cCSAus OL	Valid for signal converter IFC 100C/W and IFC 300C/F/W
<b>Other approvals and standards</b>	
Custody transfer	Only in combination with signal converter IFC 300
	<b>Cold water</b>
	MID Annex MI-001 type examination certificate
	<b>Liquids other than water</b>
	MID Annex MI-005 type examination certificate
Protection category acc. to IEC 529 / EN 60529	Standard: IP66/67 (NEMA 4/4X/6)
	IP 67/69 with IFC 100 SS (Stainless steel) converter
Shock test	IEC 68-2-27
	30 g for 18 ms
Vibration test	IEC 60068-2-24
	f = 20-2000 Hz, rms = 4.5 g, t = 30 min

## 2.2 Measuring accuracy

Every electromagnetic flowmeter is calibrated by direct volume comparison. The wet calibration validates the performance of the flowmeter under reference conditions against accuracy limits.

The accuracy limits of electromagnetic flowmeters are typically the result of the combined effect of linearity, zero point stability and calibration uncertainty.

### Reference conditions

- Medium: water
- Temperature: +5...35°C / +41...95°F
- Operating pressure: 0.1...5 barg / 1.5...72.5 psig
- Inlet section:  $\geq 5$  DN
- Outlet section:  $\geq 2$  DN

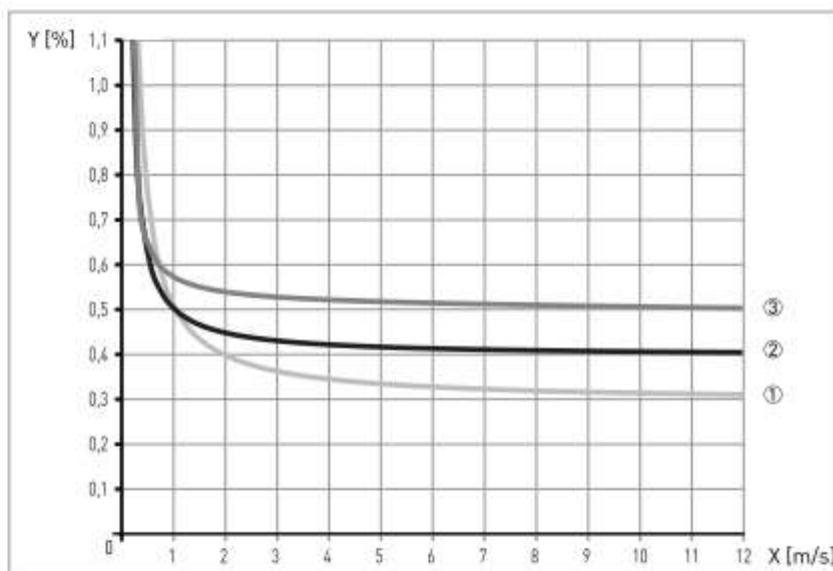

Figure 2-1: Flow velocity vs. accuracy

X [m/s]: flow velocity

Y [%]: deviation from the actual measured value (mv)

### Accuracy

Flow sensor diameter	Signal converter type	Accuracy	Curve
DN10...150 / 3/8...6"	IFC 050	0.5% of mv + 1 mm/s	③
DN10...150 / 3/8...6"	IFC 100	0.4% of mv + 1 mm/s	②
DN10...150 / 3/8...6"	IFC 300	0.3% of mv + 2 mm/s	①

2.3 Dimensions and weights

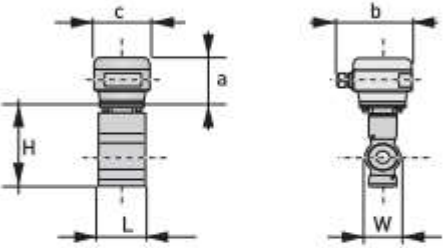
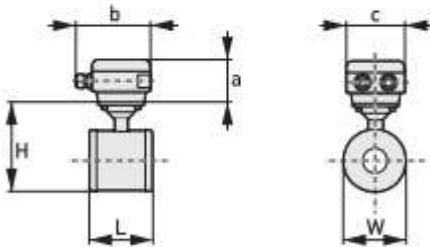
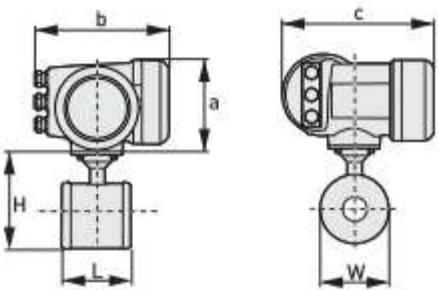
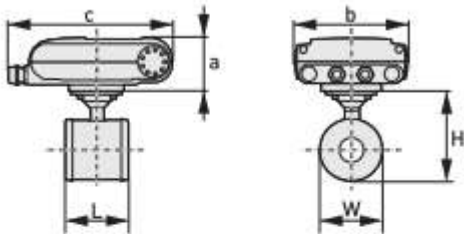
<p><b>Remote version:</b> DN10...40 / 3/8...1½"</p>		<p>a = 88 mm / 3.5"                      b = 139 mm / 5.5" ①                      c = 106 mm / 4.2"                      Total height = H + a</p>
<p><b>Remote version:</b> DN50...150" / 2...6"</p>		<p>a = 88 mm / 3.5"                      b = 139 mm / 5.5" ①                      c = 106 mm / 4.2"                      Total height = H + a</p>
<p><b>Compact version with IFC 300</b></p>		<p>a = 155 mm / 6.1"                      b = 230 mm / 9.1" ①                      c = 260 mm / 10.2"                      Total height = H + a</p>
<p><b>Compact version with IFC 100 (0°)</b></p>		<p>a = 82 mm / 3.2"                      b = 161 mm / 6.3"                      c = 257 mm / 10.1" ①                      Total height = H + a</p>

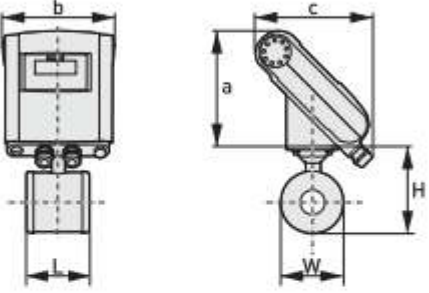
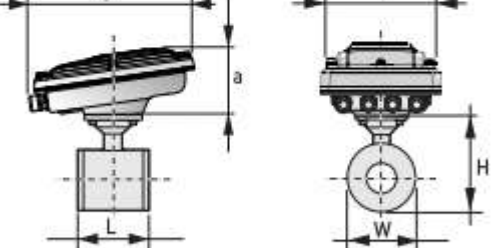
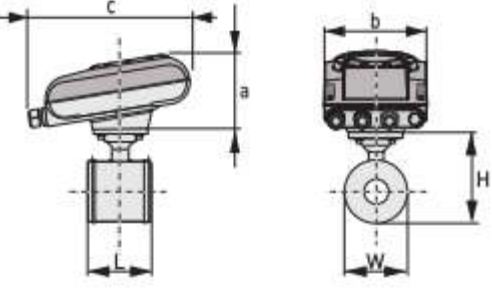
<b>Compact version with IFC 100 (45°)</b>		$a = 186 \text{ mm} / 7.3''$ $b = 161 \text{ mm} / 6.3''$ $c = 184 \text{ mm} / 2.7''$ ① Total height = $H + a$
<b>Compact stainless steel version with IFC 100 (10°)</b>		$a = 100 \text{ mm} / 4''$ $b = 187 \text{ mm} / 7.36''$ ① $c = 270 \text{ mm} / 10.63''$ Total height = $H + a$
<b>Compact version with IFC 050 (10°)</b>		$a = 101 \text{ mm} / 3.98''$ $b = 157 \text{ mm} / 6.18''$ $c = 260 \text{ mm} / 10.24''$ ① Total height = $H + a$

① The value may vary depending on the used cable glands.

- All data given in the following tables are based on standard versions of the flow sensor only.
- Especially for smaller nominal sizes of the flow sensor, the signal converter can be bigger than the flow sensor.
- Note that for other pressure ratings than mentioned, the dimensions may be different.
- For full information on signal converter dimensions see relevant documentation.

## EN 1092-1

Nominal size	Dimensions [mm]			Approx. weight [kg]
	DN	L	H	
10	68	137	47	1.7
15	68	137	47	1.7
25	54	147	66	1.7
40	78	162	82	2.6
50	100	151	101	4.2
80	150	180	130	5.7
100	200	207	156	10.5
150	200	271	219	15.0

## ASME B16.5

Nominal size	Dimensions [inch]			Approx. weight [lb]
	ASME	L	H	
3/8"	2.68	5.39	1.85	3.7
1/2"	2.68	5.39	1.85	3.7
1"	2.13	5.79	2.6	3.7
1 1/2"	3.07	6.38	3.23	5.7
2"	3.94	5.94	3.98	9.3
3"	5.91	7.08	5.12	12.6
4"	7.87	8.15	6.14	23.1
6"	7.87	10.67	8.62	33.1

### 3.1 Intended use

*Responsibility for the use of the measuring devices with regard to suitability, intended use and corrosion resistance of the used materials against the measured fluid lies solely with the operator.*

*The manufacturer is not liable for any damage resulting from improper use or use for other than the intended purpose.*

This electromagnetic flowmeter is designed exclusively to measure the flow of electrically conductive, liquid media.

### 3.2 General notes on installation

*Inspect the packaging carefully for damages or signs of rough handling. Report damage to the carrier and to the local office of the manufacturer.*

*Do a check of the packing list to make sure that you have all the elements given in the order.*

*Look at the device nameplate to ensure that the device is delivered according to your order. Check for the correct supply voltage printed on the nameplate.*

#### 3.2.1 Vibration

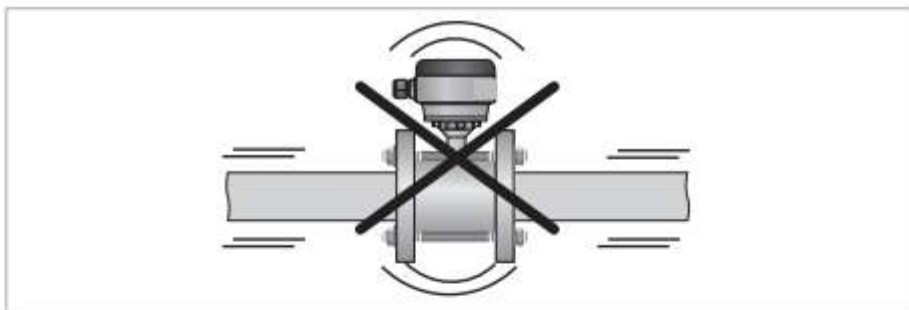

Figure 3-1: Avoid vibrations

#### 3.2.2 Magnetic field

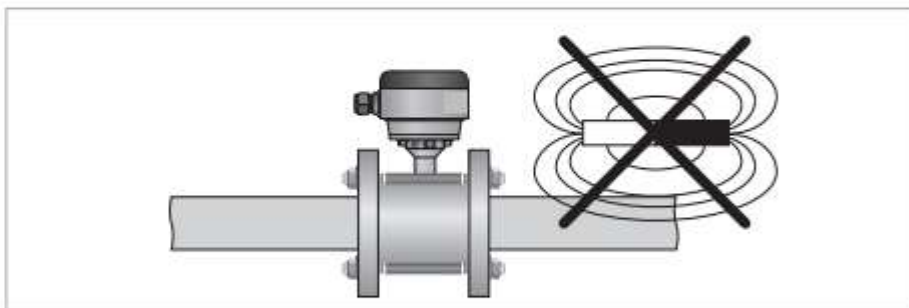

Figure 3-2: Avoid magnetic fields

### 3.3 Installation conditions

#### 3.3.1 Inlet and outlet

Use straight inlet and outlet pipe sections to prevent flow distortion or swirl, caused by bends and T- sections

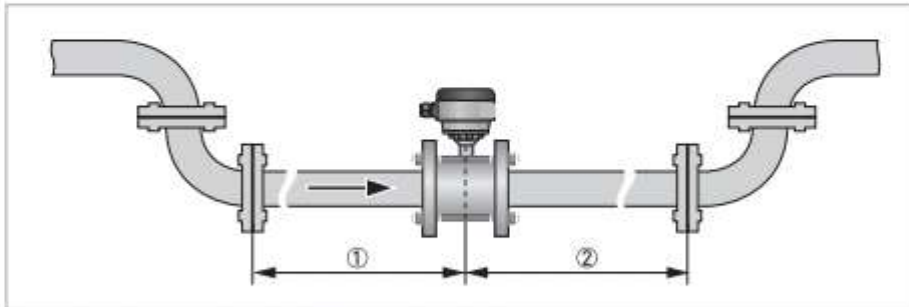

Figure 3-3: Recommended inlet and outlet section

- ① Refer to chapter "Bends in 2 or 3 dimensions"
- ②  $\geq 2$  DN

#### 3.3.2 Bends in 2 or 3 dimensions

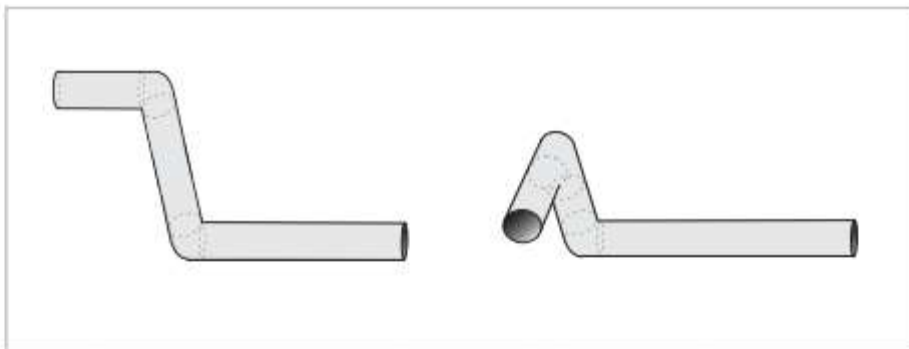

Figure 3-4: Inlet when using 2 and/or 3 dimensional bends upstream of the flowmeter

Inlet length: using bends in 2 dimensions:  $\geq 5$  DN; when having bends in 3 dimensions:  $\geq 10$  DN

*2 Dimensional bends occur in a vertical plane only, while 3 Dimensional bends occur in both vertical **and** horizontal plane.*

#### 3.3.3 T-section

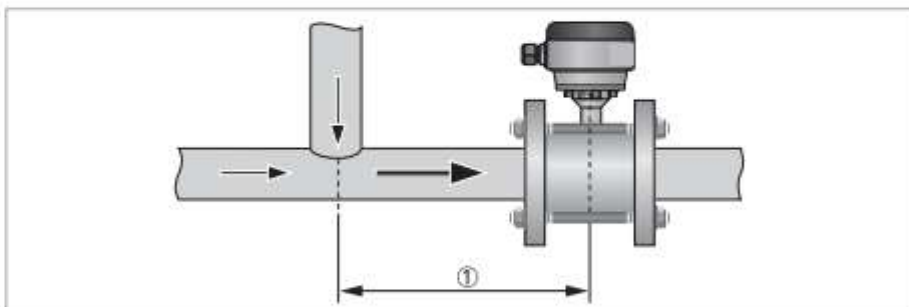

Figure 3-5: Distance behind a T-section

- ①  $\geq 10$  DN



### 3.3.4 Bends

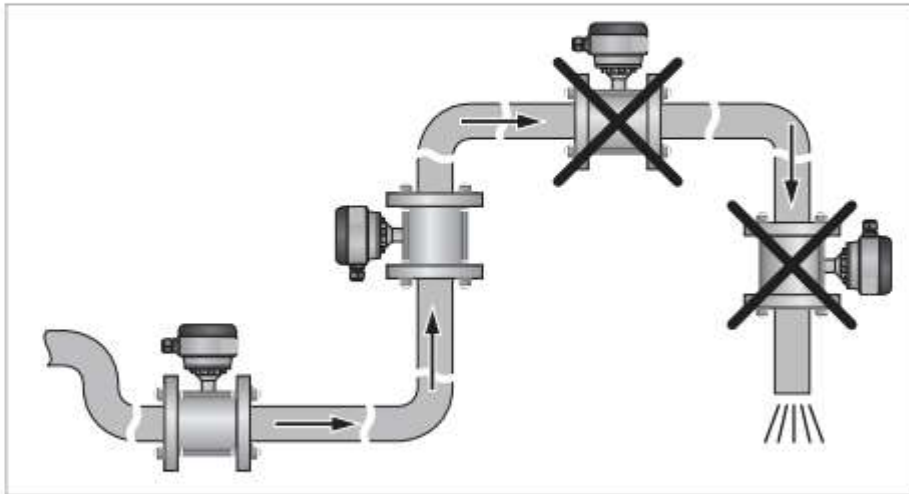

Figure 3-6: Installation in bending pipes

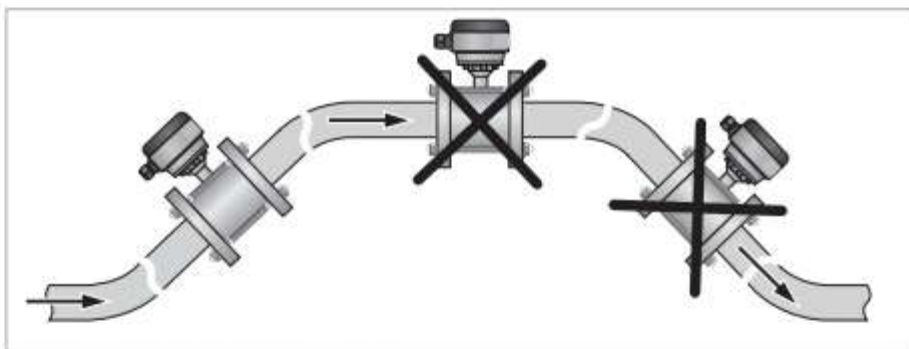

Figure 3-7: Installation in bending pipes

*Avoid draining or partial filling of the flow sensor*

### 3.3.5 Open feed or discharge

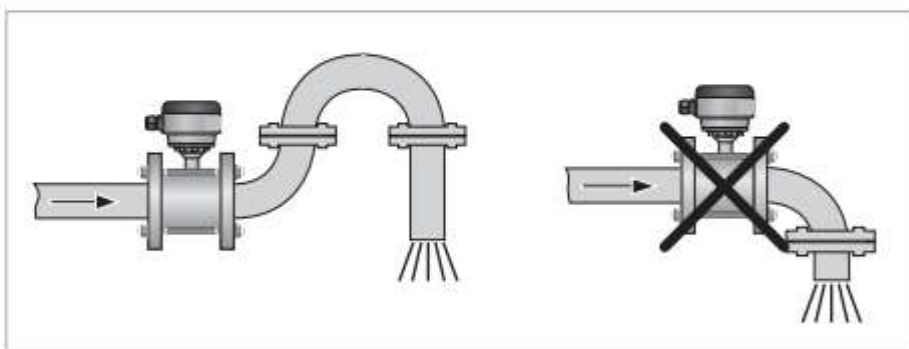

Figure 3-8: Installation in front of an open discharge

### 3.3.6 Flange deviation

Max. permissible deviation of pipe flange faces:  
 $L_{max} - L_{min} \leq 0.5 \text{ mm} / 0.02''$

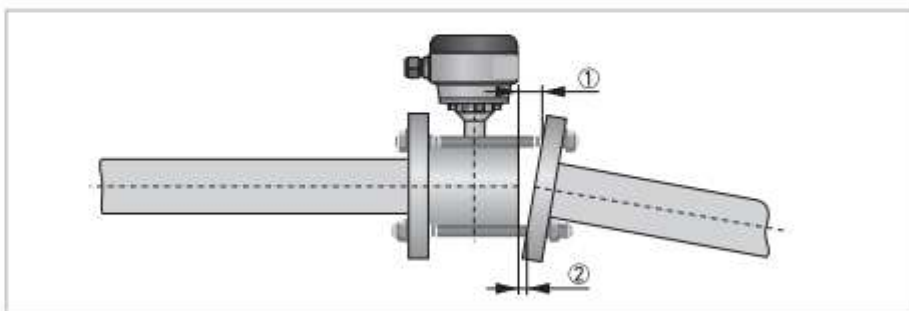

Figure 3-9: Flange deviation

- ①  $L_{max}$
- ②  $L_{min}$

### 3.3.7 Pump

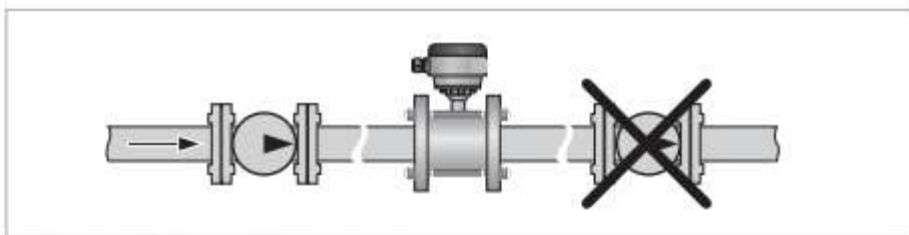

Figure 3-10: Installation behind a pump

### 3.3.8 Control valve

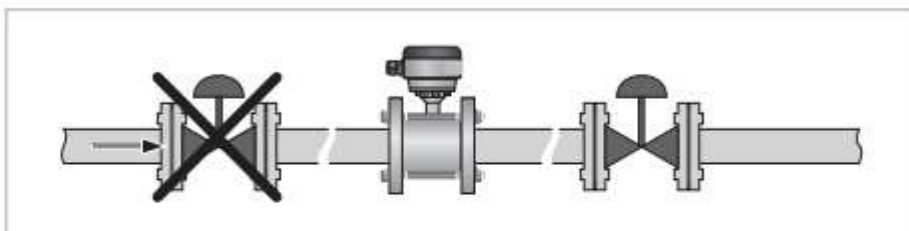

Figure 3-11: Installation in front of a control valve

### 3.3.9 Air venting and vacuum forces

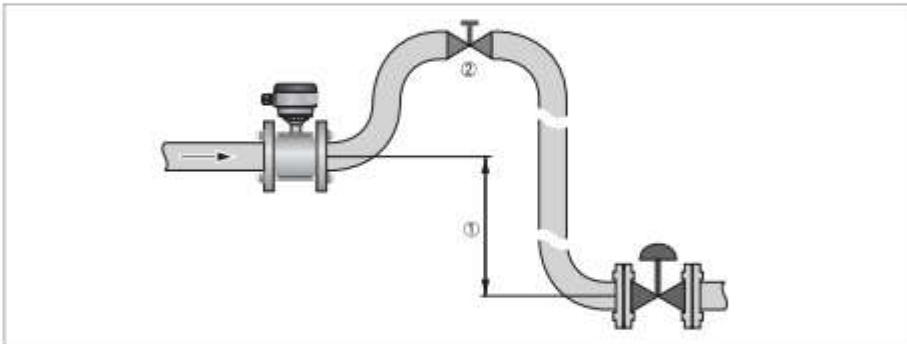

Figure 3-12: Air venting

- ①  $\geq 5$  m / 17 ft
- ② Air ventilation point

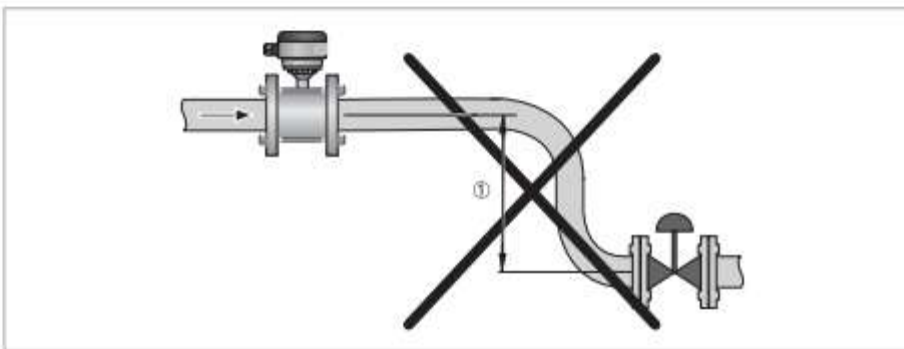

Figure 3-13: Vacuum

- ①  $\geq 5$  m / 17 ft

### 3.3.10 Mounting position

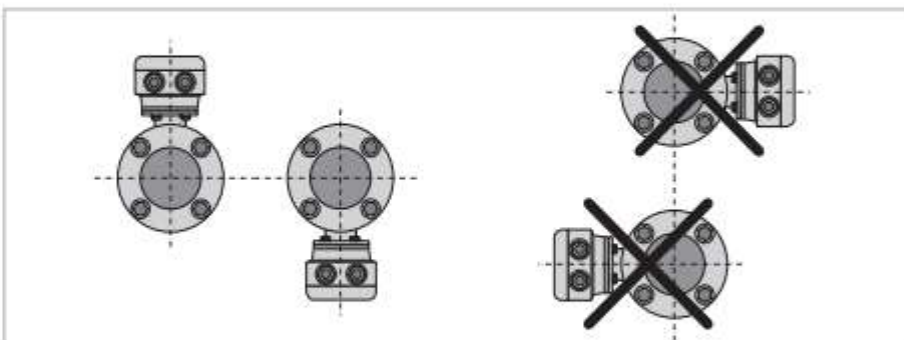

Figure 3-14: Mounting position

## 4.1 Safety instructions

*All work on the electrical connections may only be carried out with the power disconnected. Take note of the voltage data on the nameplate!*

*Observe the national regulations for electrical installations!*

*For devices used in hazardous areas, additional safety notes apply; please refer to the Ex documentation.*

*Observe without fail the local occupational health and safety regulations. Any work done on the electrical components of the measuring device may only be carried out by properly trained specialists.*

*Look at the device nameplate to ensure that the device is delivered according to your order. Check for the correct supply voltage printed on the nameplate.*

## 4.2 Grounding

*The device must be grounded in accordance with regulations in order to protect personnel against electric shocks.*

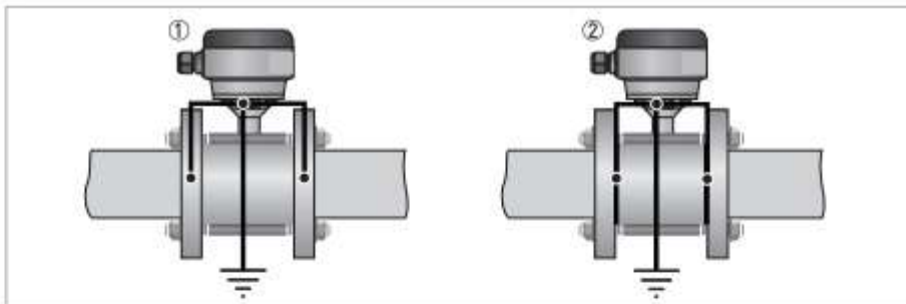

**Figure 4-1: Grounding**

- ① Metal pipelines, not internally coated. Grounding without grounding rings!
- ② Metal pipelines with internal coating and non-conductive pipelines. Grounding with grounding rings!

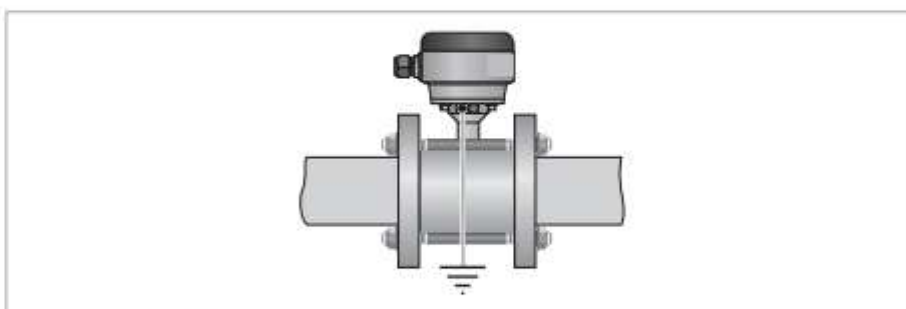

**Figure 4-2: Build-in grounding rings for DN10-15 / 3/8 - 1/2"**

*For diameter DN10 / 3/8" and DN15 / 1/2", grounding rings are integrated as standard in the flow sensor construction.*

### Grounding rings



Figure 4-3: Grounding ring number 1

**Grounding ring number 1 (optional for DN25...150 / 1...6"):** Thickness: 3 mm / 0.1"

## 4.3 Virtual reference for IFC 300

The virtual reference option on the IFC 300 flow converter provides complete isolation of the measurement circuit.

### Benefits of virtual reference:

- Grounding rings or grounding electrodes can be omitted.
- Safety increases by reducing the number of potential leakage points.
- The installation of the flowmeters is much easier.

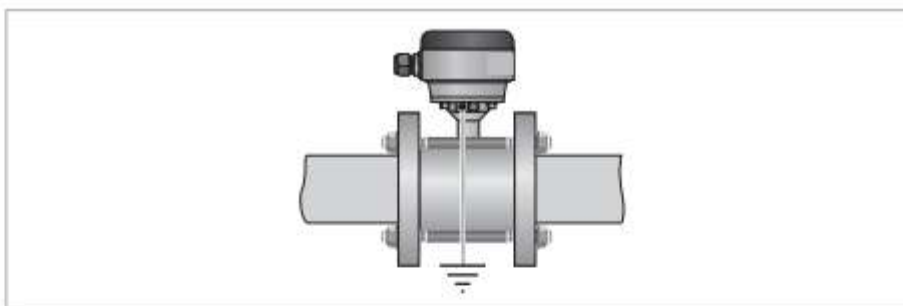

Figure 4-4: Virtual reference

### Minimum requirements:

- Size:  $\geq$  DN10 / 3/8"
- Electrical conductivity:  $\geq$  200  $\mu$ S/cm
- Electrode cable: max. 50 m / 164 ft, type DS



## KROHNE – Process instrumentation and measurement solutions

- Flow
- Level
- Temperature
- Pressure
- Process Analysis
- Services

Head Office KROHNE Messtechnik GmbH  
Ludwig-Krohne-Str. 5  
47058 Duisburg (Germany)  
Tel.: +49 203 301 0  
Fax: +49 203 301 10389  
info@krohne.com

The current list of all KROHNE contacts and addresses can be found at:  
[www.krohne.com](http://www.krohne.com)

**KROHNE**