



## OPTIFLUX 7300 **Technical Datasheet**

Electromagnetic flowmeter with non wetted electrodes and ceramic liner

- No insulation of electrodes
- Stable measurement in noisy applications
- Improved safety and hygiene with absolute leak tight design

1 Product features	3
1.1 Non wetted electrodes with high tech ceramic liner	3
1.2 Features	5
1.3 Measuring principle	7
2 Technical data	8
2.1 Technical data	8
2.2 Dimensions and weights	19
3 Installation	23
3.1 Notes on installation	23
3.2 Installation conditions	23
3.2.1 Inlet and outlet	23
3.2.2 Mounting position	23
3.2.3 Flange deviation	24
3.2.4 T-section	24
3.2.5 Vibration	24
3.2.6 Magnetic field	25
3.2.7 Bends	25
3.2.8 Open discharge	26
3.2.9 Control valve	26
3.2.10 Air venting	26
3.2.11 Pump	27
3.2.12 Temperatures	27
4 Electrical connections	28
4.1 Safety instructions	28
4.2 Grounding	28
4.3 Connection diagrams	29
5 Notes	30

## 1.1 Non wetted electrodes with high tech ceramic liner

The OPTIFLUX 7300 combines the advantages of non wetted capacitive electrodes, a ceramic liner and the IFC 300 converter. This electromagnetic flowmeter can be used for noisy applications, low conductivities, mediums tending to form an insulating film, applications with high vibrations, and oxidizing, abrasive and toxic mediums.

Instead of conventional electrodes that have a direct contact with the process liquid, OPTIFLUX 7300 has a non-contacting capacitive signal pick-up. The electrodes are designed as large-area capacitor plates, mounted behind the ceramic liner.

Because the electrodes have no contact with the medium, unwanted catalytic action with metallic parts is eliminated. A second benefit is that the insulation of electrodes no longer forms a risk. In case of a medium that tends to form a non conductive surface coating on the tube wall, the signal pick up between medium and electrodes will not be interrupted.

The smooth and pore free ceramic tube construction does not leak and is CIP / SIP resistant, making it highly suitable for hygienic applications in for example the food & beverage and pharmaceutical industry. It is very hard, non permeable and has an extreme and broad chemical resistance, fulfilling requirements of the chemical industry.

The construction of the OPTIFLUX 7300 offers an absolute leak tight solution, because leakage through the liner and leakage along the electrodes is not possible.

The IFC 300 converter standardly includes extensive diagnostics of the process and meter and powerful filter settings for stable flow measurements.



- ① Stainless steel sensor housing
- ② Ceramic liner
- ③ Capacitor plates for signal pick up behind the liner

### Highlights

- Ceramic liner with non wetted electrodes
- Excellent chemical and abrasion resistance
- Increased safety and hygiene with absolutely leak tight design
- No metals in contact with the medium
- No insulation of the electrodes
- No wear or corrosion of the electrodes
- Stable flow measurement
- Low conductivities to 0.05  $\mu\text{S}/\text{cm}$
- Fully vacuum resistant
- Insensitive for temperature shocks
- Sterile and hygienic; conformity to FDA requirements
- Excellent long term stability and accuracy
- Alternative for mass flowmeter (for the price of an electromagnetic flowmeter)

### Industries

- Chemical
- Food & beverage
- Pharmaceutical
- Paper & pulp
- Wastewater
- Machine building
- Primaries

### Applications

- Toxic, aggressive and abrasive mediums
- Emulsions: latex, emulsion paints
- Adhesives
- Organic mass production
- Low conductive mediums: (bio-) alcohols, spirits, glycols, glycerine
- Abrasive slurries
- Water mixed with oil or metallic particles
- Fibrous products
- Oil-based products: vegetable oils
- Dairy products: fat creams, milk, cheese, yoghurt with fruit particles
- Cement

## 1.2 Features

### Non wetted, capacitive electrodes

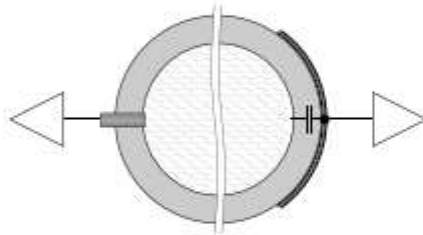

The electrodes are designed as large-area capacitor plates, fitted onto the outside of the ceramic tube. The non-wetted signal pick-up offers major benefits over a classic wetted electrode design:

- No metals in contact with the medium
- No risk of insulation of electrodes
- No leakage
- No wear or corrosion of electrodes
- Minimum conductivity of the medium down to  $0.05 \mu\text{S}/\text{cm}$
- More stable flow indication with inhomogeneous media.

With non wetted capacitive electrodes noise is significantly reduced because there is no electromechanical interaction or particles hitting electrodes.

### Ceramic liner with conical design



The ceramic liner of the OPTIFLUX 7300 has an excellent abrasion resistance, is extremely hard, dimensionally stable and has a low thermal expansion coefficient. The chemical resistance is excellent and broad. It is also smooth, pore-free and non-permeable.

These features result in the following advantages:

- High wear resistance, and therefore very suitable for abrasive fluids
- Absolute vacuum resistance
- Very suitable for aggressive media
- Exceptional long term stability
- High measurement accuracy also under unfavorable measurement conditions
- No crevices, no gaps, no bacteria growth
- No leaching of the ceramic into the medium
- Suitable for CIP /SIP

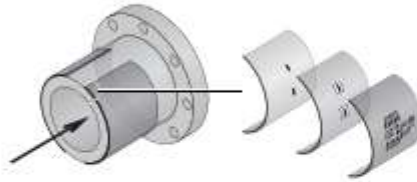
**All electronic parts rigidly fixed to the ceramic tube**

With OPTIFLUX 7300 noise is not only reduced by capacitive electrodes but also by the rigid construction of the electronic parts.

All electronic parts are fully integrated with the ceramic tube using LTCC (Low Temperature Co-fired Ceramic) technology. The capacitive electrodes, shielding and pre-amplifiers are sintered in three layers of LTCC tape on the ceramic tube. This results in a very rigid and fixed construction, eliminating relative movements of these parts. This is also known as microphonic effects. The use of non-piezo electric materials avoids piezo-electric noise that can be induced when using plastic insulation materials.

The benefits of the highly rigid design are a high noise and vibration immunity.

### 1.3 Measuring principle

An electrically conductive fluid flows inside an electrically insulated pipe through a magnetic field. This magnetic field is generated by a current, flowing through a pair of field coils. Inside of the fluid, a voltage  $U$  is generated:

$$U = v \cdot k \cdot B \cdot D$$

in which:

$v$  = mean flow velocity

$k$  = factor correcting for geometry

$B$  = magnetic field strength

$D$  = inner diameter of flow meter

The signal voltage  $U$  is picked off by electrodes and is proportional to the mean flow velocity  $v$  and thus the flow rate  $q$ . A signal converter is used to amplify the signal voltage, filter it and convert it into signals for totalising, recording and output processing.

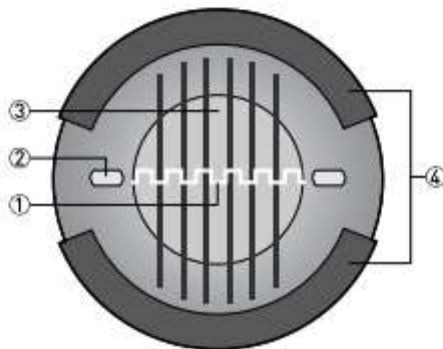

- ① Induced voltage (proportional to flow velocity)
- ② Electrodes (capacitive)
- ③ Magnetic field
- ④ Field coils

## 2.1 Technical data

- *The following data is provided for general applications. If you require data that is more relevant to your specific application, please contact us or your local representative.*
- *Additional information (certificates, special tools, software,...) and complete product documentation can be downloaded free of charge from the website (Download Center).*

### Measuring system

Measuring principle	Farady's law of induction
Application range	Continuous measurement of the volumetric flow rate of electrically conductive liquids.
<b>Measured value</b>	
Primary measured value	Flow velocity
Secondary measured value	Volume flow, mass flow

### Design

Features	Sandwich / flanged version with optimized flow tube
Modular construction	The measurement system consists of a flow sensor and a signal converter. It is available as compact version only. More information about the signal converter can be found in the documentation of the signal converter.
Compact version	With IFC 300 C / CAP converter: OPTIFLUX 7300 C
Nominal diameter	DN25, 40, 50, 80, 100 / 1", 1½", 2", 3" and 4".
Measurement range	-12...+12 m/s / -40...+40 ft/s
<b>Signal converter</b>	
Outputs / inputs	Current- (incl. HART®), pulse, frequency and/or status output, limit switch and/or control input, current input (depends on the I/O version)
Counters	2 (optional 3) internal counters with a max. of 8 counter places (e.g. for counting volume and/or mass units)
Verification	Intergrated verification, diagnostic functions: measuring device, process, measured value, empty pipe detection, stabilization.
Communication interfaces	Foundation Fieldbus, Profibus PA and DP, Modbus, HART®
<b>User interface</b>	
Display	LC Display, backlit white
	Size: 128 x 64 pixel, corresponds to 59 x 31 mm / 2.32" x 1.22"
	Display can be turned in steps of 90°
Operating elements	Ambient temperature below -25°C / -13°F, may effect the readability of the display.
	4 optical keys for operator control of the signal converter without opening the housing. Infrared interface for reading and writing all parameters with IR interface (option) without opening the housing.



Remote control	PACTware® (incl. Device Type Manager (DTM))
	HART® Hand Held Communicator from Emerson Process
	AMS® from Emerson Process
	PDM® from Siemens
	All DTMs and drivers are available free of charge from the manufacturer's website.
<b>Display functions</b>	
Operating menu	Setting the parameters using 2 measured value pages, 1 status page, 1 graphics page (measured values and graphics are freely adjustable).
Language display texts (as language package)	Standard: English, French, German, Dutch, Portuguese, Swedish, Spanish, Italian
	Eastern Europe: English, Slovenian, Czech, Hungarian
	Northern Europe: English, Danish, Polish
	China: English, Chinese
	Russia: English, Russian
Units	Metric, British and US units selectable as required from lists for volume / mass flow and counting, flow velocity, temperature.

### Measuring accuracy

Reference conditions	Flow conditions: similar to EN 29104
	Medium: water
	Temperature: 20°C / 68°F
	In-/outlet section: 10 DN / 5 DN
	Flow velocity: > 1 m/s / > 3 ft/s
	Operating pressure: 1 bar / 14.5 psig
	Valve closing time variation: < 1 ms
	Wet calibrated on EN 17025 accredited calibration rig by direct volume comparison.
Maximum measuring error	±0.5% of measured value ±5 mm/s
	Related to volume flow.
	These values are related to the pulse / frequency output.
	The additional typical measuring deviation for the current output is ±10 µA.
Repeatability	±0.1% of MV, minimum 1 mm/s
Long term stability	±0.1% of MV
Special calibration	On request

## Operating conditions

<b>Temperature</b>		
Process temperature	-40...100°C / -40...+212°F (up to 120°C / 248°F for up to 30 min.) For Ex versions different temperature ranges are applicable. Please see the relevant Ex documentation for details.	
Maximum temperature change (shock)	Rising: 125°C / 257°F (in 10 min.); 120°C / 248°F (sudden change) Falling: 100°C / 212°F (in 10 min.); 80°C / 176°F (sudden change)	
Ambient temperature	Non-Ex: -40...+65°C / -40...+149°F Ex: -40...+60°C / -40...+140°F	
Storage temperature	-50...+70°C / -58...+158°F	
<b>Pressure</b>		
	<b>OPTIFLUX 7300 C - SW</b>	<b>OPTIFLUX 7300 C - FL</b>
Ambient pressure	Atmospheric	Atmospheric
Nominal flange pressure		
EN 1092-1	<b>Standard:</b> DN100: PN 16 DN25...80: PN 40 <b>Option:</b> DN100: PN 25	<b>Standard:</b> DN100: PN 16 DN25...80: PN 40 <b>Option:</b> -
ASME B16.5	<b>Standard:</b> 1...4": 150 lb <b>Option:</b> 1...3": 300 lb 4": 300 lb Max. pressure is 30 bar / 435 psig	<b>Standard:</b> 1...4": 150 lb <b>Option:</b> 1...3": 300 lb
Vacuum load	0 mbar / 0 psig	0 mbar / 0 psig
<b>Chemical properties</b>		
Physical condition	Liquids	
Electrical conductivity	0.05 µS/cm Demineralised cold water: ≥ 1 µS/cm	
Permissible gas content (volume)	≤ 5%	
Permissible solid content	≤ 70%	

## Installation conditions

Installation	Take care that the flow sensor is always fully filled. For detailed information see chapter "Installation".
Flow direction	Forward and reverse Arrow on flow sensor indicates positive flow direction.
Inlet run	≥ 5 DN (without disturbing flow, after a single 90° bend) ≥ 10 DN (after a double bend 2x90°) ≥ 10 DN (behind a control valve)
Outlet run	≥ 2 DN
Dimensions and weights	For detailed information see chapter "Dimensions and weights".

### Materials

	OPTIFLUX 7300 C - SW	OPTIFLUX 7300 C - FL
Sensor housing	Stainless steel AISI 304 [1.4306]	Stainless steel AISI 316 [1.4408]
Measuring tube	Ceramic	Ceramic
Flange	-	Stainless steel AISI 316 [1.4408]
Measuring electrodes	Non wetted, capacitive	Non wetted, capacitive
Grounding rings	Stainless steel, Hastelloy® C, Titanium, Tantalum	-
	Other materials on request.	-
Stud bolts and nuts	Standard: steel	-
	Option: stainless steel, rubber, centering sleeves	-
Gaskets	Gylon®, PTFE-PF 29, Chemotherm®	PTFE sealing rings
	Other materials on request.	-
Signal converter housing	Standard: die-cast aluminium (polyurethane-coated)	
	Option: stainless steel 316 L [1.4408]	

### Process connections

	OPTIFLUX 7300 C - SW	OPTIFLUX 7300 C - FL
EN 1092-1	<b>Standard</b>	
	DN100 in PN 16	DN100 in PN 16
	DN25...80 in PN 40	DN25...80 in PN 40
	<b>Option</b>	
	Option: DN100 in PN 25	-
ASME	<b>Standard</b>	
	1...4" in 150 lb	1...4" in 150 lb
	<b>Option</b>	
	1...3" in 300 lb	1...3" in 300 lb
	4" in 300 lb Max. pressure is 30 bar / 435 psig	

### Electrical connection

General	Electrical connection is carried out in conformity with the VDE 0100 directive "Regulations for electrical power installations with line voltages up to 1000 V" or equivalent national regulations.
Voltage	<b>Standard</b>
	100...230 VAC (-15% / +10%), 50/60 Hz
	<b>Options</b>
	24 VDC (-55% / +30% )
	24 VAC/DC (AC: -15% / +10%, 50/60 Hz; DC: -25% / +30%)
Power consumption	AC: 22 VA
	DC: 12 W
Cable entries	Standard: M20 x 1.5 [8...12 mm]
	Option: ½" NPT, PF ½

## Inputs and outputs

General	All outputs are electrically isolated from each other and from all other circuits.		
	All operating data and output values can be adjusted.		
Description of the used abbreviations	$U_{ext}$ = external voltage $R_L$ = load + resistance $U_0$ = terminal voltage $I_{nom}$ = nominal current <b>Safety limit values (Ex i):</b> $U_i$ = max. input voltage $I_i$ = max. input current $P_i$ = max. input power rating $C_i$ = max. input capacity $L_i$ = max. input inductivity		
<b>Current output</b>			
Output data	Volume flow, mass flow, diagnostics value, flow velocity, coil temperature.		
Settings	<b>Without HART®</b>		
	Q = 0%: 0...20 mA		
	Q = 100%: 10...21.5 mA		
	Error identifications: 10...21.5 mA		
	<b>With HART®</b>		
	Q = 0%: 4...20 mA		
	Q = 100%: 10...21.5 mA		
	Error identifications: 3.5...22 mA		
Operating Data	<b>Basic I/Os</b>	<b>Modular I/Os</b>	<b>Ex i</b>
Active	$U_{int, nom} = 24$ VDC		$U_{int, nom} = 20$ VDC
	$I \leq 22$ mA		$I \leq 22$ mA
	$R_L \leq 1$ k $\Omega$		$R_L \leq 450$ $\Omega$
			$U_0 = 21$ V $I_0 = 90$ mA $P_0 = 0.5$ W $C_0 = 90$ nF / $L_0 = 2$ mH $C_0 = 110$ nF / $L_0 = 0.5$ mH
Passive	$U_{ext} \leq 32$ VDC		$U_{ext} \leq 32$ VDC
	$I \leq 22$ mA		$I \leq 22$ mA
	$U_0 \geq 1.8$ V		$U_0 \geq 4$ V
	$R_L \leq (U_{ext} - U_0) / I_{max}$		$R_L \leq (U_{ext} - U_0) / I_{max}$
			$U_i = 30$ V $I_i = 100$ mA $P_i = 1$ W $C_i = 10$ nF $L_i = 0$ mH

<b>HART®</b>			
Description	HART® protocol via active and passive current output.		
	HART® version: V5		
	Universal HART® parameter: completely integrated		
Load	≥ 250 Ω at HART® test point.		
	Note maximum load for current output!		
Multidrop operation	Yes, current output = 4mA		
	Multidrop address adjustable in operation menu 1...15		
Device driver	Available for FC 375, AMS, PDM, FDT/DTM		
Registration (HART® Communication Foundation)	Yes		
<b>Pulse or frequency output</b>			
Output data	Pulse output: volume flow, mass flow		
	Frequency output: volume flow, mass flow, diagnostic value, flow velocity, coil temperature		
Function	Adjustable as pulse or frequency output.		
Pulse rate/frequency	0.01...10000 pulses/s or Hz		
Settings	Pulses per volume or mass unit or max. frequency for 100% flow.		
	Pulse width: adjustable as automatic, symmetric or fixed [0.05...2000 ms]		
Operating data	<b>Basic I/Os</b>	<b>Modular I/Os</b>	<b>Ex i</b>
Active		$U_{nom} = 24 \text{ VDC}$ $f_{max}$ in operating menu set to $f_{max} \leq 100 \text{ Hz}$ : $I \leq 20 \text{ mA}$ open: $I \leq 0.05 \text{ mA}$ closed: $U_{0, nom} = 24 \text{ V}$ at $I = 20 \text{ mA}$	
		$f_{max}$ in operating menu set to $100 \text{ Hz}$ $< f_{max} \leq 10 \text{ kHz}$ : $I \leq 20 \text{ mA}$ open: $I \leq 0.05 \text{ mA}$ closed: $U_{0, nom} = 22.5 \text{ V}$ at $I = 1 \text{ mA}$ $U_{0, nom} = 21.5 \text{ V}$ at $I = 10 \text{ mA}$ $U_{0, nom} = 19 \text{ V}$ at $I = 20 \text{ mA}$	

Passive	$U_{\text{ext}} \leq 32 \text{ VDC}$		
	$f_{\text{max}}$ in operating menu set to $f_{\text{max}} \leq 100 \text{ Hz}$ : $I \leq 100 \text{ mA}$ $R_{L, \text{max}} = 47 \text{ k}\Omega$ $R_{L, \text{min}} = (U_{\text{ext}} - U_0) / I_{\text{max}}$ open: $I \leq 0.05 \text{ mA}$ at $U_{\text{ext}} = 32 \text{ VDC}$ closed: $U_{0, \text{max}} = 0.2 \text{ V}$ at $I \leq 10 \text{ mA}$ $U_{0, \text{max}} = 2 \text{ V}$ at $I \leq 100 \text{ mA}$		
NAMUR	-	$f_{\text{max}}$ in operating menu set to $100 \text{ Hz} < f_{\text{max}} \leq 10 \text{ kHz}$ : $I \leq 20 \text{ mA}$ $R_{L, \text{max}} = 47 \text{ k}\Omega$ $R_{L, \text{min}} = (U_{\text{ext}} - U_0) / I_{\text{max}}$ open: $I \leq 0.05 \text{ mA}$ at $U_{\text{ext}} = 32 \text{ VDC}$ closed: $U_{0, \text{max}} = 1.5 \text{ V}$ at $I \leq 1 \text{ mA}$ $U_{0, \text{max}} = 2.5 \text{ V}$ at $I \leq 10 \text{ mA}$ $U_{0, \text{max}} = 5.0 \text{ V}$ at $I \leq 20 \text{ mA}$	
		Passive to EN 60947-5-6 open: $I_{\text{nom}} = 0.6 \text{ mA}$ closed: $I_{\text{nom}} = 3.8 \text{ mA}$	Passive to EN 60947-5-6 open: $I_{\text{nom}} = 0.43 \text{ mA}$ closed: $I_{\text{nom}} = 4.5 \text{ mA}$ $U_i = 30 \text{ V}$ $I_i = 100 \text{ mA}$ $P_i = 1 \text{ W}$ $C_i = 10 \text{ nF}$ $L_i = 0 \text{ mH}$

<b>Low flow cut-off</b>			
Function	Switching point and hysteresis separately adjustable for each output, counter and the display.		
Switching point	Set in increments of 0.1. 0...20% (current output, frequency output) or 0...±9.999 m/s (pulse output)		
Hysteresis	Set in increments of 0.1. 0...5% (current output, frequency output) or 0...5 m/s (pulse output)		
<b>Time constant</b>			
Function	The time constant corresponds to the elapsed time until 67% of the end value has been reached according to a step function.		
Settings	Set in increments of 0.1. 0...100 s		
<b>Status output / limit switch</b>			
Functions and settings	Adjustable as automatic measuring range conversion, display of flow direction, counter overflow, error, switching point or empty pipe detection. Valve control with activated dosing function. Status and/or control: ON or OFF		
Operating data	Basic I/Os	Modular I/Os	Ex i
Active	-	$U_{int} = 24 \text{ VDC}$ $I \leq 20 \text{ mA}$ open: $I \leq 0.05 \text{ mA}$ closed: $U_{0, nom} = 24 \text{ V}$ at $I = 20 \text{ mA}$	-
Passive	$U_{ext} \leq 32 \text{ VDC}$ $I \leq 100 \text{ mA}$ $R_{L, max} = 47 \text{ k}\Omega$ $R_{L, min} = (U_{ext} - U_0) / I_{max}$ open: $I \leq 0.05 \text{ mA}$ at $U_{ext} = 32 \text{ VDC}$ closed: $U_{0, max} = 0.2 \text{ V}$ at $I \leq 10 \text{ mA}$ $U_{0, max} = 2 \text{ V}$ at $I \leq 100 \text{ mA}$		-
NAMUR	-	Passive to EN 60947-5-6 open: $I_{nom} = 0.6 \text{ mA}$ closed: $I_{nom} = 3.8 \text{ mA}$	Passive to EN 60947-5-6 open: $I_{nom} = 0.43 \text{ mA}$ closed: $I_{nom} = 4.5 \text{ mA}$ $U_i = 30 \text{ V}$ $I_i = 100 \text{ mA}$ $P_i = 1 \text{ W}$ $C_i = 10 \text{ nF}$ $L_i = 0 \text{ mH}$

<b>Control input</b>			
Function	Hold output values (e.g. when cleaning), set value of outputs to "zero", counter and error reset, range conversion.		
	Start of dosing when dosing function is activated.		
Operating data	Basic I/Os	Modular I/Os	Ex i
Active	-	$U_{int} = 24 \text{ VDC}$ Ext. contact open: $U_{0, nom} = 22 \text{ V}$ Ext. contact closed: $I_{nom} = 4 \text{ mA}$ Contact closed (on): $U_0 \geq 12 \text{ V}$ with $I_{nom} = 1.9 \text{ mA}$ Contact open (off): $U_0 \leq 10 \text{ V}$ with $I_{nom} = 1.9 \text{ mA}$	-
Passive	$8 \text{ V} \leq U_{ext} \leq 32 \text{ VDC}$ $I_{max} = 6.5 \text{ mA}$ at $U_{ext} \leq 24 \text{ VDC}$ $I_{max} = 8.2 \text{ mA}$ at $U_{ext} \leq 32 \text{ VDC}$ Contact closed (on): $U_0 \geq 8 \text{ V}$ with $I_{nom} = 2.8 \text{ mA}$ Contact open (off): $U_0 \leq 2.5 \text{ V}$ with $I_{nom} = 0.4 \text{ mA}$	$3 \text{ V} \leq U_{ext} \leq 32 \text{ VDC}$ $I_{max} = 9.5 \text{ mA}$ at $U_{ext} \leq 24 \text{ V}$ $I_{max} = 9.5 \text{ mA}$ at $U_{ext} \leq 32 \text{ V}$ Contact closed (on): $U_0 \geq 3 \text{ V}$ with $I_{nom} = 1.9 \text{ mA}$ Contact open (off): $U_0 \leq 2.5 \text{ V}$ with $I_{nom} = 1.9 \text{ mA}$	$U_{ext} \leq 32 \text{ VDC}$ $I \leq 6 \text{ mA}$ at $U_{ext} = 24 \text{ V}$ $I \leq 6.6 \text{ mA}$ at $U_{ext} = 32 \text{ V}$ On: $U_0 \geq 5.5 \text{ V}$ or $I \geq 4 \text{ mA}$ Off: $U_0 \leq 3.5 \text{ V}$ or $I \leq 0.5 \text{ mA}$ $U_i = 30 \text{ V}$ $I_i = 100 \text{ mA}$ $P_i = 1 \text{ W}$ $C_i = 10 \text{ nF}$ $L_i = 0 \text{ mH}$
NAMUR	-	Active to EN 60947-5-6 Terminals open: $U_{0, nom} = 8.7 \text{ V}$ Contact closed (on): $U_{0, nom} = 6.3 \text{ V}$ with $I_{nom} > 1.9 \text{ mA}$ Contact open (off): $U_{0, nom} = 6.3 \text{ V}$ with $I_{nom} < 1.9 \text{ mA}$ Detection of cable break: $U_0 \geq 8.1 \text{ V}$ with $I \leq 0.1 \text{ mA}$ Detection of cable short circuit: $U_0 \leq 1.2 \text{ V}$ with $I \geq 6.7 \text{ mA}$	-



<b>Current input</b>			
Function	The following values can be delivered from the measuring sensor to the current input: temperature, pressure and current.		
Operating data	<b>Basic I/Os</b>	<b>Modular I/Os</b>	<b>Ex i</b>
Active	-	$U_{int, nom} = 24 \text{ VDC}$ $I \leq 22 \text{ mA}$ $I_{max} \leq 26 \text{ mA}$ (electronically limited) $U_{0, min} = 19 \text{ V}$ at $I \leq 22 \text{ mA}$ No HART®	$U_{int, nom} = 20 \text{ VDC}$ $I \leq 22 \text{ mA}$ $U_{0, min} = 14 \text{ V}$ at $I \leq 22 \text{ mA}$ No HART®
			$U_0 = 24.5 \text{ V}$ $I_0 = 99 \text{ mA}$ $P_0 = 0.6 \text{ W}$ $C_0 = 75 \text{ nF} / L_0 = 0.5 \text{ mH}$ No HART®
Passive	-	$U_{ext} \leq 32 \text{ VDC}$ $I \leq 22 \text{ mA}$ $I_{max} \leq 26 \text{ mA}$ (electronically limited) $U_{0, max} = 5 \text{ V}$ at $I \leq 22 \text{ mA}$ No HART®	$U_{ext} \leq 32 \text{ VDC}$ $I \leq 22 \text{ mA}$ $U_{0, max} = 4 \text{ V}$ at $I \leq 22 \text{ mA}$ No HART®
			$U_i = 30 \text{ V}$ $I_i = 100 \text{ mA}$ $P_i = 1 \text{ W}$ $C_i = 10 \text{ nF}$ $L_i = 0 \text{ mH}$ No HART®
<b>PROFIBUS DP</b>			
Description	Galvanically isolated acc. to IEC 61158		
	Profile version: 3.01		
	Automatic data transmission rate recognition (max. 12 Mbaud)		
	Bus address adjustable via local display at the measuring device.		
Function blocks	5 x analogue input, 3 x totalizer		
Output data	Volume flow, mass flow, volume counter 1 + 2, mass counter, velocity, coil temperature		
<b>PROFIBUS PA</b>			
Description	Galvanically isolated acc. to IEC 61158		
	Profile version: 3.01		
	Current consumption: 10.5 mA		
	Permissible bus voltage: 9...32 V; in Ex application: 9...24 V		
	Bus interface with integrated reverse polarity protection.		
	Typical error current FDE (Fault Disconnection Electronic): 4.3 mA		
	Bus address adjustable via local display at the measuring device.		
Function blocks	5 x analogue input, 3 x totalizer		
Output data	Volume flow, mass flow, volume counter 1 + 2, mass counter, velocity, coil temperature		

<b>FOUNDATION Fieldbus</b>	
Description	Galvanically isolated acc. to IEC 61158
	Current consumption: 10.5 mA
	Permissible bus voltage: 9...32 V; in Ex application: 9...24 V
	Bus interface with integrated reverse polarity protection.
	Link Master function (LM) supported
	Tested with Interoperable Test Kit (ITK) version 5.1
Function blocks	3 x analogue input, 2x integrator
Output data	Volume flow, mass flow, volume counter 1 + 2, mass counter, velocity, coil temperature
<b>Modbus</b>	
Description	Modbus RTU, Master / Slave, RS485
Address range	1...247
Supported function codes	03, 04, 16
Broadcast	Supported with function code 16
Supported Baudrate	1200, 2400, 4800, 9600, 19200, 38400, 57600, 115200 Baud

### Approvals and certifications

<b>CE</b>	
	The device fulfills the statutory requirements of the EC directives. The manufacturer certifies successful testing of the product by applying the CE mark.
Electromagnetic compatibility	Directive: 2004/108/EC and A1, A2 NAMUR NE21/04
	Harmonized standard: EN 61326-1 : 2006
Low Voltage Directive	Directive: 2006/95/EC
	Harmonized standard: EN 61010 : 2002
Pressure Equipment Directive	Directive: 97/23/EC
	Category, I, II or SEP
	Fluid group 1
	Production module H
<b>Other approvals and standards</b>	
Non-Ex	Standard
<b>Hazardous areas</b>	
	Please check the relevant Ex documentation for details.
ATEX	KEMA 10 ATEX 0105 X
	For gas: zone 1 and 2, gasgroup IIC, temperature class T6...T4
	For dust: zone 21 and 22, maximum surface temperature T115°C
Protection category acc. to IEC 529 / EN 60529	IP 66/67 (NEMA 4/4X/6)
Hygiene	Ceramic measuring tube is conform FDA regulations.
Vibration resistance	IEC 68-2-6

## 2.2 Dimensions and weights

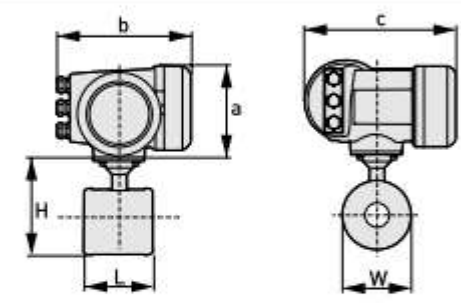
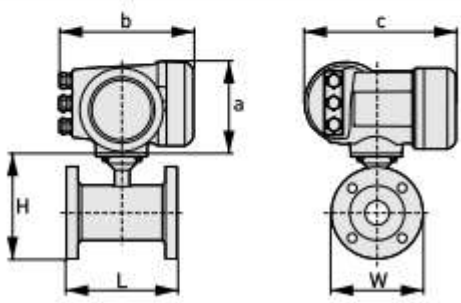
<b>Sandwich version</b>		$a = 155 \text{ mm} / 6.1''$ $b = 230 \text{ mm} / 9.1''$ ① $c = 260 \text{ mm} / 10.2''$ Total height = $H + a$
<b>Flanged version</b>		$a = 155 \text{ mm} / 6.1''$ $b = 230 \text{ mm} / 9.1''$ ① $c = 260 \text{ mm} / 10.2''$ Total height = $H + a$

① The value may vary depending on the used cable glands.

- All data given in the following tables are based on standard versions of the sensor only.
- Especially for smaller nominal sizes of the sensor, the converter can be bigger than the sensor.
- Note that for other pressure ratings than mentioned, the dimensions may be different.
- For full information on converter dimensions see relevant documentation.

Sandwich version

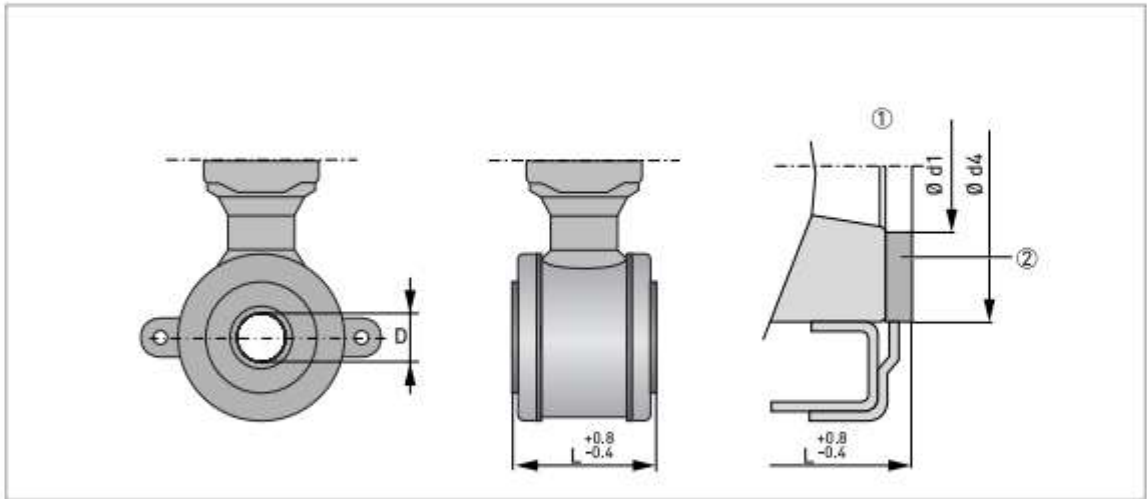

Figure 2-1: Construction details DN25...100

- ① Situation without grounding rings
- ② Gasket

Nominal size	Dimensions [mm]						Approx. weight [kg]
	DN	L	H	W	D	Ød1	
25	58 ①	116	68	20	26	46	1.6
40	83 ①	131	83	30	39	62	2.4
50	103 ①	149	101	40	51	74	2.9
80	153 ①	181	133	60	80	106	6.4
100	203 ①	206	158	80	101	133	8.8

① Total fitting length of flowmeter without rings: dimension L only.

The table below is valid for 150 and 300 lb.

Nominal size	Dimensions [inches]						Approx. weight [lb]
	ASME	L	H	W	D	Ød1	
1"	2.28 ①	4.57	2.68	0.79	1.02	1.81	3.53
1½"	3.27 ①	5.16	3.27	1.18	1.54	2.44	5.29
2"	4.06 ①	5.87	3.98	1.57	2.01	2.91	6.39
3"	6.02 ①	7.13	5.24	2.36	3.15	4.17	14.11
4"	7.99 ①	8.11	6.22	3.15	3.98	5.24	19.40

① Total fitting length of flowmeter without rings: dimension L only.

## Flanged version

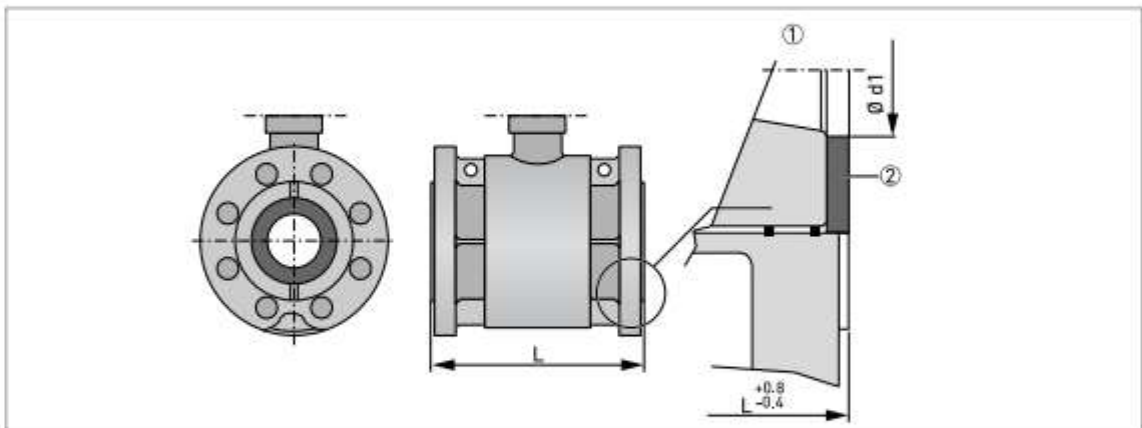

Figure 2-2: Construction details DN25...100

- ① Detail ceramics / flange / gaskets
- ② PTFE sealing ring

## EN 1092-1

Nominal size	Dimensions [mm]					Approx. weight [kg]
	DN	L	H	W	D	
25	150	143	115	20	26	4
40	150	168	150	30	39	6
50	200	184	165	40	51	9
80	200	217	200	60	80	15
100	250	242	220	80	101	21

## ASME B 16.5 150 lb

Nominal size	Dimensions [inches]					Approx. weight [lb]
inch	L	H	W	D	Ød1	
1"	5.91	5.47	4.25	0.79	1.02	8.8
1½"	5.91	6.18	5	1.18	1.54	13.2
2"	7.87	6.89	6	1.57	2.01	19.8
3"	7.87	8.39	7.5	2.36	3.15	33.1
4"	9.84	9.65	9	3.15	3.98	46.3

## ASME B 16.5 300 lb

Nominal size	Dimensions [inches]					Approx. weight [lb]
inch	L	H	W	D	Ød1	
1"	5.91	5.91	4.92	0.79	1.02	8.8
2"	7.87	7.20	6.50	1.57	2.01	22.9
3"	7.87	8.86	8.27	2.36	3.15	40.6

### 3.1 Notes on installation

*Inspect the cartons carefully for damage or signs of rough handling. Report damage to the carrier and to the local office of the manufacturer.*

*Check the packing list to check if you received completely all that you ordered.*

*Look at the device nameplate to ensure that the device is delivered according to your order. Check for the correct supply voltage printed on the nameplate.*

### 3.2 Installation conditions

#### 3.2.1 Inlet and outlet

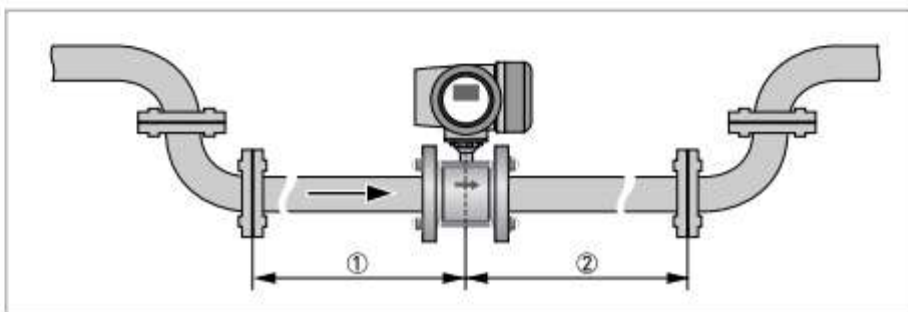

Figure 3-1: Recommended inlet and outlet sections

- ①  $\geq 5$  DN
- ②  $\geq 2$  DN

#### 3.2.2 Mounting position

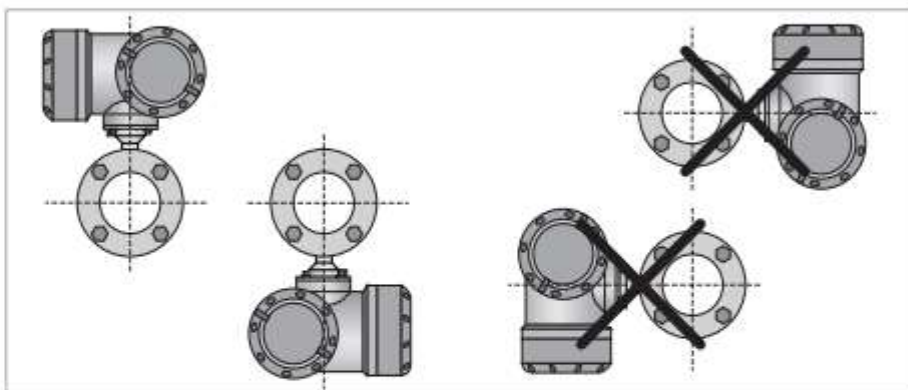

Figure 3-2: Mounting position

### 3.2.3 Flange deviation

Max. permissible deviation of pipe flange faces:  
 $L_{max} - L_{min} \leq 0.5 \text{ mm} / 0.02''$

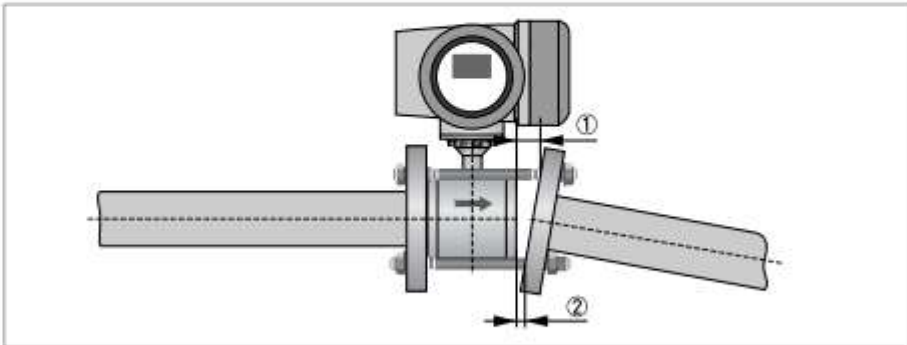

Figure 3-3: Flange deviation

- ①  $L_{max}$
- ②  $L_{min}$

### 3.2.4 T-section

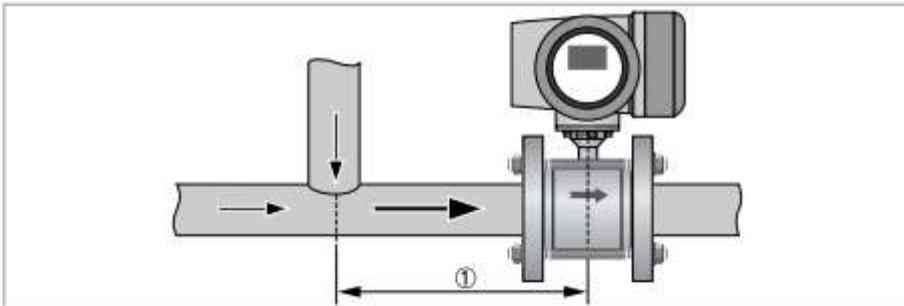

Figure 3-4: Distance after T-sections

- ①  $\geq 10 \text{ DN}$

### 3.2.5 Vibration

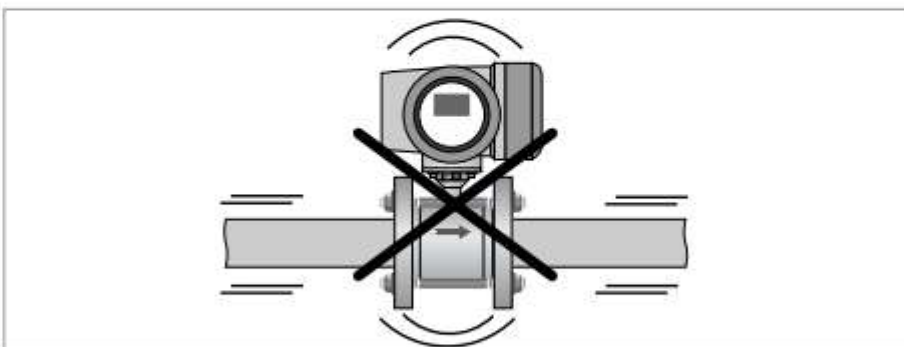

Figure 3-5: Avoid vibrations



### 3.2.6 Magnetic field

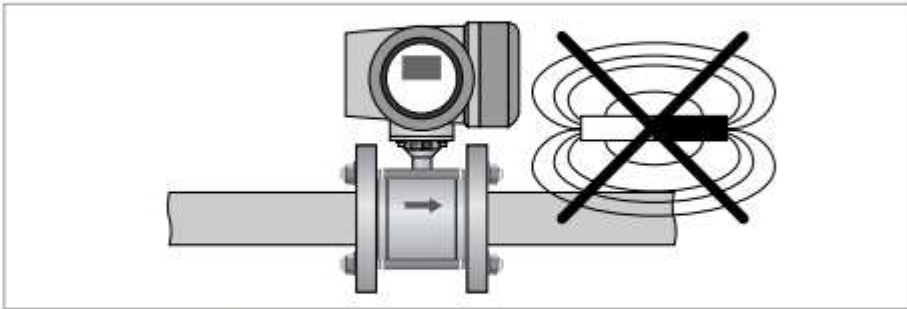

Figure 3-6: Avoid magnetic fields

### 3.2.7 Bends

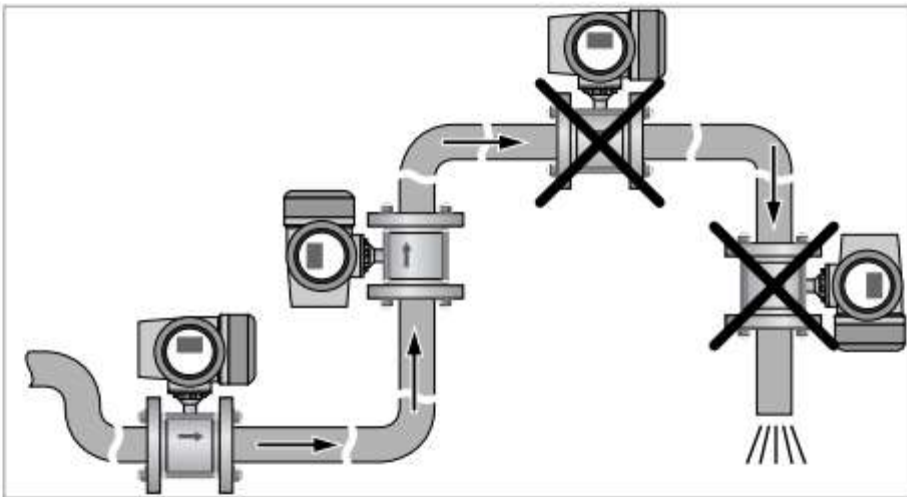

Figure 3-7: Installation in bending pipes

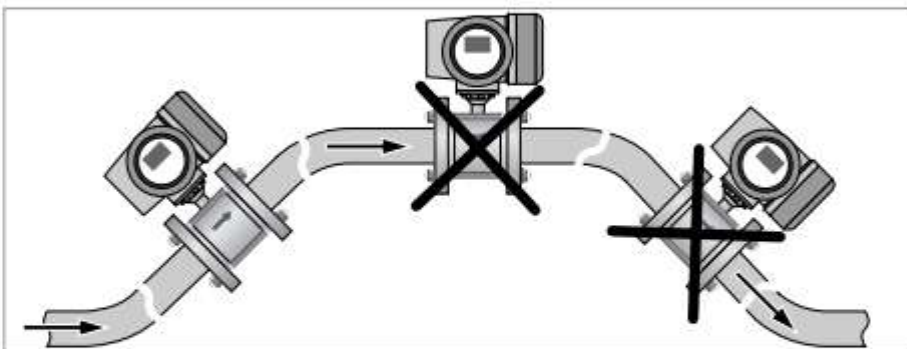

Figure 3-8: Installation in bending pipes

## 3.2.8 Open discharge

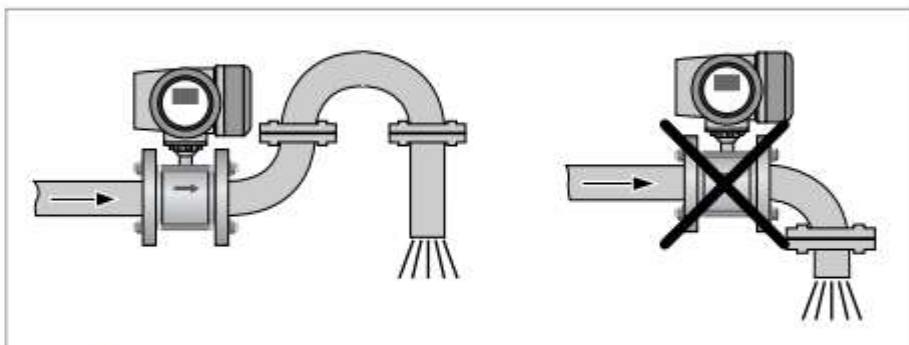

Figure 3-9: Installation before an open discharge

## 3.2.9 Control valve

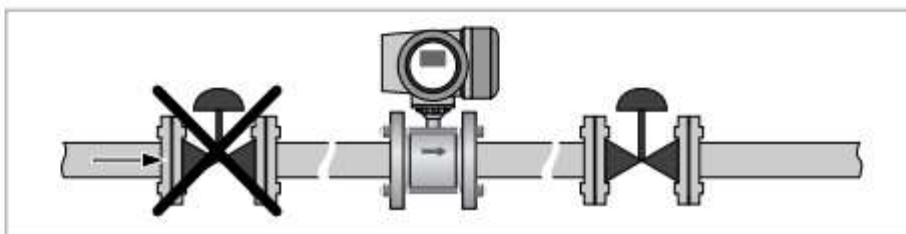

Figure 3-10: Installation before control valve

## 3.2.10 Air venting

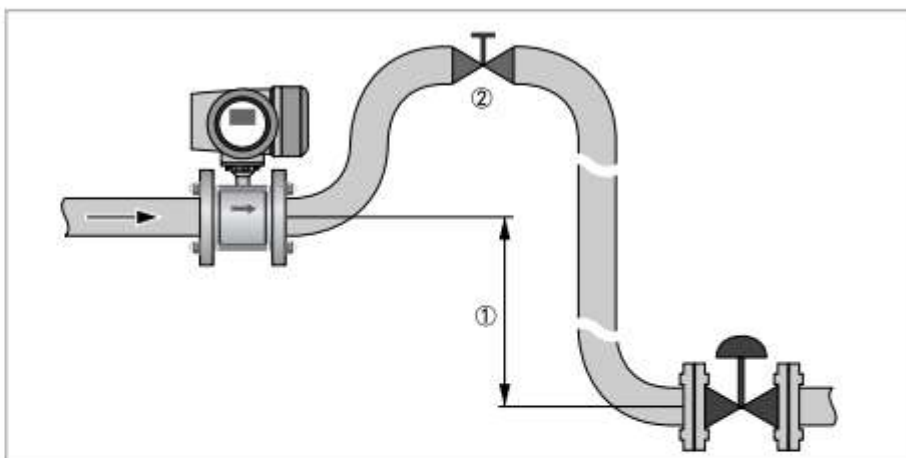

Figure 3-11: Air venting

①  $\geq 5$  m

② Air ventilation point

### 3.2.11 Pump

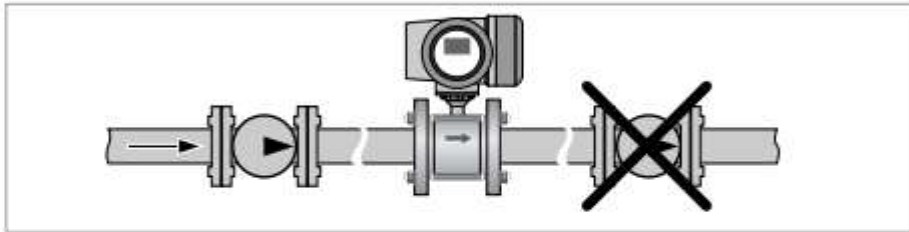

Figure 3-12: Installation after pump

### 3.2.12 Temperatures

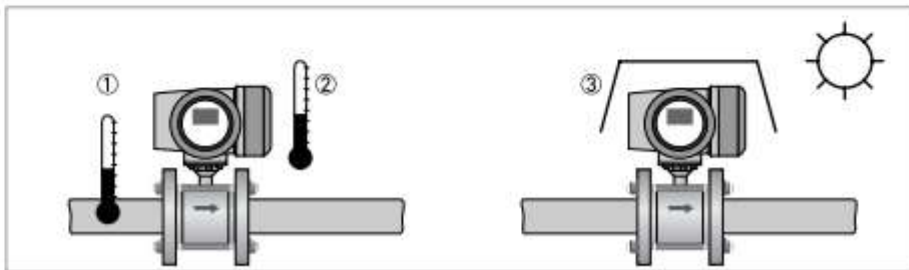

Figure 3-13: Temperatures

- ① Process temperature
- ② Ambient temperature
- ③ Sunshade

*Protect the device from direct sunlight.*

Temperature range	Process [°C]		Ambient [°C]		Process [°F]		Ambient [°F]	
	min.	max.	min.	max.	min.	max.	min.	max.
Compact + IFC 300	-40	100	-40	65	-40	212	-40	149

## 4.1 Safety instructions

*All work on the electrical connections may only be carried out with the power disconnected. Take note of the voltage data on the nameplate!*

*Observe the national regulations for electrical installations!*

*Observe without fail the local occupational health and safety regulations. Any work done on the electrical components of the measuring device may only be carried out by properly trained specialists.*

*Look at the device nameplate to ensure that the device is delivered according to your order. Check for the correct supply voltage printed on the nameplate.*

## 4.2 Grounding

*The device must be grounded in accordance with regulations in order to protect personnel against electric shocks.*

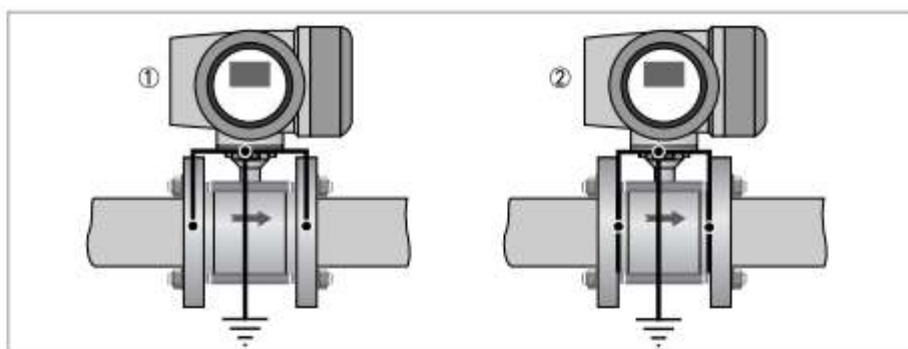

Figure 4-1: Grounding

- ① Metal pipelines, not internally coated. Grounding without grounding rings.
- ② Metal pipelines with internal coating and non-conductive pipelines. Grounding with grounding rings.



Figure 4-2: Grounding ring number 1

**Grounding ring number 1 (for type VN19):**

- 3 mm / 0.1" thick (tantalum: 0.5 mm / 0.1")

### 4.3 Connection diagrams

*For the connection diagrams please refer to the documentation of the applicable converter.*



### KROHNE product overview

- Electromagnetic flowmeters
- Variable area flowmeters
- Ultrasonic flowmeters
- Mass flowmeters
- Vortex flowmeters
- Flow controllers
- Level meters
- Temperature meters
- Pressure meters
- Analysis products
- Measuring systems for the oil and gas industry
- Measuring systems for sea-going tankers

Head Office KROHNE Messtechnik GmbH  
Ludwig-Krohne-Str. 5  
D-47058 Duisburg (Germany)  
Tel.: +49 (0)203 301 0  
Fax: +49 (0)203 301 10389  
info@krohne.de

The current list of all KROHNE contacts and addresses can be found at:  
[www.krohne.com](http://www.krohne.com)

**KROHNE**