



## **KGA 42** Technical Datasheet

Datalogger with GSM / GPRS communication

1 Product features	3
1.1 Introduction .....	3
1.2 Features.....	5
2 Technical data	6
2.1 Technical data.....	6
2.2 Dimensions and weights .....	9
3 Installation	10
3.1 Notes on installation .....	10
3.2 Installation .....	10
3.2.1 Mounting bracket .....	11
3.2.2 Opening / closing the housing .....	12
3.2.3 Inserting the SIM-card .....	14
3.3 Diagnostics .....	15
4 Electrical connections	16
4.1 Safety instructions.....	16
4.2 Inputs of the KGA 42 .....	16
5 Notes	18

## 1.1 Introduction

The KGA 42 is a data logger with an integrated GSM / GPRS module. It is battery operated, watertight (IP 68) and easy to install. When combined with the - also battery driven - WATERFLUX 3070, it forms a perfect solution for monitoring water distribution networks.

Applications:

- remote meter reading
- leakage detection
- district metering
- warning messages in case of calamities

Competitively priced, the KGA 42 ensures a rapid return on investment by contributing efficiently to improving network yield.



## Highlights

### Datalogging

- capacity in GSM mode 2000 records; in GPRS mode 6000 records
- no data loss in case of power failure (empty battery)

### GSM / GPRS communication

- built-in GSM / GPRS modem for data transmission
- SMS alarm messages
- built-in high performance antenna designed for the installation in manholes (low reception levels, disturbances caused by the concrete structure and manhole cover, etc.)

### Visual LED-based diagnostics

- LED-based operator dialog
- start-up and maintenance assistance (power on / off, connection to GSM network, reception level, etc.)

### Bluetooth communication

- wireless connection with PC or pocket PC
- ability to work outside a manhole
- configuration read / write
- full diagnostics and data viewing

### Water tightness

- sealing concept that guarantees water tightness (IP 68)
- military grade connections

### Autonomous power supply

- long-life lithium battery
- very low power consumption guarantees an autonomy of years
- sensor power feeding (suitable for passive output)
- permanent power consumption metering

## 1.2 Features

### Meterings and flows

When connected to flowmeters positioned at strategic points in a water network, the KGA 42 provides information concerning the behaviour of each monitored zone. Metering index recording and flow rate are calculated at a user-defined frequency.

### Measurements

In addition to metering and flow monitoring, network sectoring may require pressure monitoring. The KGA 42 offers 2 analog inputs (AI) to connect 4-20 mA sensors that are directly powered by the KGA 42. Measurements are acquired and saved at a user-defined frequency.

### Calculations and archiving

Average flow rates, daily volumes and night time flow rates (MNF) are automatically calculated by the KGA 42. The values are archived according to data types:

- meterings (indices and average flow rates)
- analog inputs (pressure measurements, etc.)
- daily reports (night time flow rates (MNF), indices, volumes, min. / max. flow rates)

Archives and reports are sent to internet each day. Through a dedicated web site (WEB KGA) the data can be viewed or exported for further analysis.

### Signalling and warnings

Inputs (DI) can be assigned to switches to notify specific events (manhole cover open, flow meter fault, etc.). A change in signalling status can trigger the transmission of status or warning SMS messages to a mobile phone. A timer can be configured to filter out undesirable status changes.

### Ease of operation

Each KGA 42 is supplied with a CD-ROM, containing Softools software. Softools is a configuration and diagnostic tool. It combines ease of use and an intuitive graphical environment:

- Configuration: the configuration wizard guides users through the steps involved configuring a KGA 42. The successive screens are used to rapidly and easily set the main operating parameters. Configuration read and write operations are performed over a bluetooth link.
- Diagnostics: Softools facilitates KGA 42 installation and can be used for various operating tests: input (DI and AI) tests, best GSM / GPRS operator test, reception level test to determine optimal location of the KGA 42, etc.
- Viewing: during manual activation, the metering, measurements and flow rates can be viewed. It is also possible to accurately determine the power consumed by the KGA 42, along with the battery's remaining lifetime.

### LED diagnostics

Different coloured LED's on the KGA 42 provide diagnostic information (power on/off, SIM card present, network connection, reception level)

## 2.1 Technical data

- The following list is just an excerpt of the most important technical data. Special options are available on request.
- Additional information and complete product documentation can be downloaded free of charge from the website (Download center).

### Measuring system

Application range	automatic collection of counter and flow values; this data is transmitted through GPRS to a centralised system daily.
Measured value	
Primary measured value	digital and analog input signals
Secondary measured value	average flow rates, daily volumes and night time flow rates

### Design

Modular construction	the measurement system is water tight [IP 68], autonomous and consists of single casing with all necessary electronics inside
Case	possible to wall-mount using only 2 screws
Aerial	standard: built-in GSM / GPRS antenna option: external antenna
Key	option: enables waking up the unit for Bluetooth communication and to run operating diagnostics (communication test, meter indexing, GSM / GPRS reception level, etc.)
Opening wrench	option: specific tool for correct opening and closing of the casing, it matches the locking system and maintains the instrument's seal
USB Bluetooth adapter	option: to communicate with the KGA 42
Remote version	to be connected to the pulse- and / or status output(s) of an IFC 070 signal converter

### User interface

Softtools	software package to configure the KGA 42 included with each KGA 42
WEB KGA	web based solution for the data collection
<p>Note: Other scenarios for the data collection from the KGA 42 (as SCADA, OPC server, PC WIN and PC WEB) are possible. <b>These are NOT in the scope of KROHNE and are thus not supported.</b></p>	

### Operating conditions

Ambient temperature	-20...+55°C / -4...+131°F
Storage temperature	-25...+70°C / -13...+158°F

### Installation conditions

Dimensions and weights	for detailed information, refer to <i>Dimensions and weights</i> on page 9.
------------------------	---

**Materials**

Housing	ABS (Acrylonitrile Butadiene Styrene)
Cover	ABS
Closing ring	ABS
Wall bracket	ABS

**Electrical connections**

Power supply	standard: battery code '934'
	option: high capacity battery code '933'
Battery replacement	possible without loss of data

**In- and outputs**

Inputs	4x digital input (DI, for pulse and / or status input):
	<ul style="list-style-type: none"> <li>• 2x pulse input (pulse width <math>\geq 2</math> ms)</li> <li>• 2x status input</li> </ul>
	2x analog input (AI, 4...20mA)
Outputs	GSM / GPRS for data transmission
	GSM for SMS warning messages
Cable connections	watertight bayonet connector (military grade)
Cable length	up to 2 m / 6 ft

## Approvals and certifications

General	<p>The instrument is powered by a lithium metal battery; only those batteries indicated by the device manufacturer are suitable to guarantee its safety and performance levels.</p> <p>The presence of a lithium battery positions this device in <b>"category UN3091 - Class 9"</b> of the UN list of hazardous materials. As such, the transport of this device must conform to prevailing rules that are specific to the means of transport used, both in terms of packaging, identification and accompanying documents. In all cases, the carrier must be informed of the specific contents of the package.</p> <p>The warning label 'Hazard label for Class 9 - Miscellaneous Hazardous Goods' is affixed onto the packaging and remains visible on the outside of the package.</p>
CE Sign	EN 60950 - in accordance with current European regulations, the device is intended for use in industrial environments. It presents no hazardous voltage, in accordance with the low voltage directive.
Hazardous areas	n/a
Other approvals and standards	
Low voltage directive	Directive 73/23/EEC modified 93/68/EEC EN 60950 (data processing hardware safety): electric shock, energy transfer hazard, fire, mechanical and thermal hazards
Electromagnetic compatibility	<p>Directive 2004/108/EC</p> <p>Housing:</p> <ul style="list-style-type: none"> <li>EN 55022 (data processing instruments (class B) emissions): Radiation disturbances</li> <li>EN 55024 (industrial environment immunity): electrostatic discharge acc. EN 61000-4-2, electromagnetic field acc. EN 61000-4-3</li> </ul> <p>In- and outputs:</p> <ul style="list-style-type: none"> <li>EN 55024 (industrial environment immunity): fast transient bursts acc. EN 61000-4-4, shock waves acc. EN 61000-4-5, conducted disturbances acc. EN61000-4-6</li> </ul>
Telecommunication	Directive 1999/5/EC ETSI EN 301 511 - GSM 900 and DCS 1800 access
Humidity	Directive IEC 529 / EN 60529 IP 68 / NEMA 6P (1 m under water, up to 100 days)
Environmental protection	<p>WEEE directives 2002/96/EC and 2003/108/EC</p> <p>Collection and sorting of WEEE (Waste Electrical and Electronic Equipment), processing, recycling and non-polluting disposal. For reasons of environmental protection, spent products should be returned to their respective suppliers for waste recycling</p>



## 2.2 Dimensions and weights

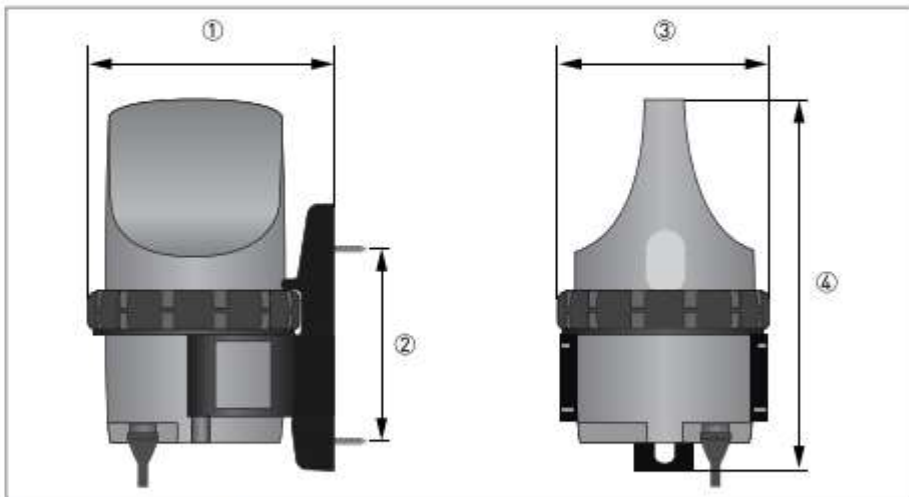

Figure 2-1: Dimensions of the KGA 42

- ① 176 mm / 6.93"
- ② 148 mm / 5.83"
- ③ 155 mm / 6.10"
- ④ 261 mm / 10.28"

The weight is approximately 1 kg / 2.2 lb.

### 3.1 Notes on installation

*Inspect the cartons carefully for damages or signs of rough handling. Report damage to the carrier and to the local office of the manufacturer.*

*Do a check of the packing list to make sure that you have all the elements given in the order.*

*Look at the device nameplate to ensure that the device is delivered according to your order. Check for the correct supply voltage printed on the nameplate.*

### 3.2 Installation

*The instrument has an IP 68 protection rating; it is fully protected against the effect of immersion and can be fitted in a manhole in a wet or flood-prone environment.*

*To optimise GSM communications, it's position in the manhole must be carefully chosen; it should generally be kept away from the manhole cover.*

*Install the housing vertically on its bracket, in accordance with the housing's top and bottom.*

*The tests should be conducted in a real situation, with the manhole cover closed:*

- 1. the indicator lights on the instrument provide an initial diagnostic level.*
- 2. Softools - in diagnostic mode - can be used to search for the best GSM operator*
- 3. find the best position for the housing in the manhole using the 'reception level test' function (via Softools in diagnostic mode)*

### 3.2.1 Mounting bracket

The bracket must be securely mounted (screws and plugs are not in the scope of supply).

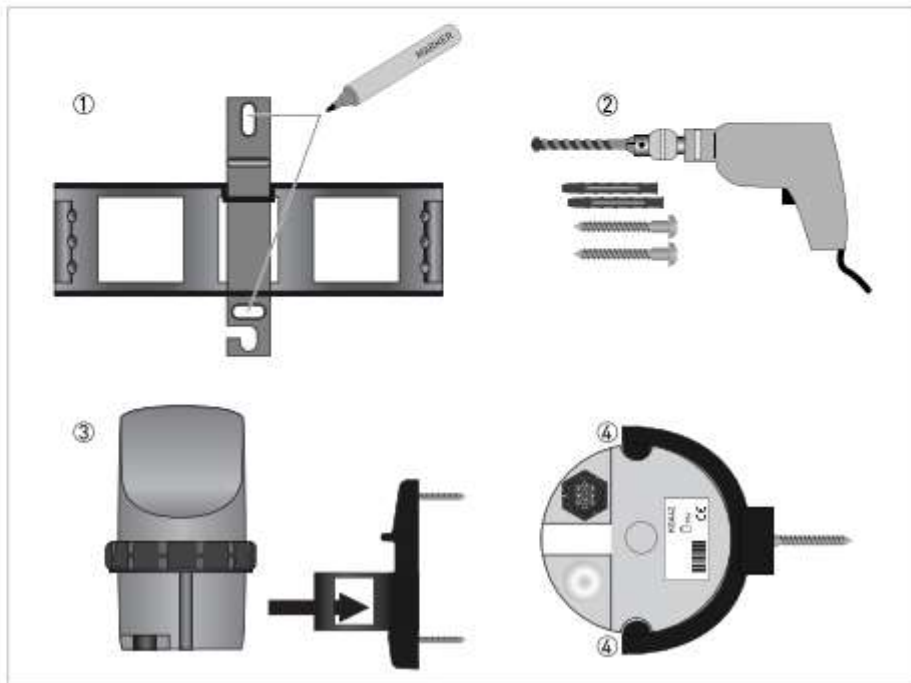

Figure 3-1: Mounting the holder

- ① Mark the fixation points.
- ② Drill the holes and mount the holder with the right screws (eg. M4 x 30) and plugs.
- ③ Slide the KGA 42 into the holder as shown.
- ④ Make sure that the holder snaps into the housing of the KGA 42.

### 3.2.2 Opening / closing the housing

The instrument can be kept water tight by screwing the housing ring tightly. The housing must not be opened except for inserting the SIM-card or replacing the battery. To open the case, it is recommended:

- to lock the housing in the upside down position, either between your knees, or in a vise [though care must be taken to avoid damaging the plastic]
- to insert the tool into the notches provided for this purpose and to rotate it clockwise [in this position the tightening and loosening directions are reversed]

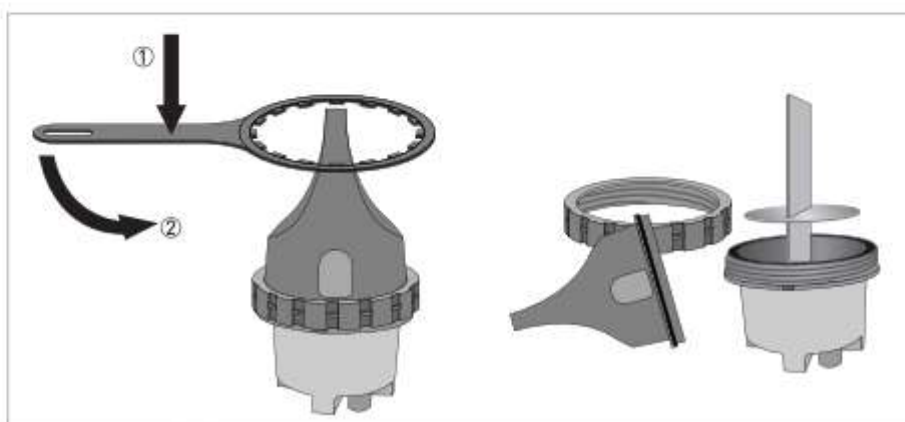
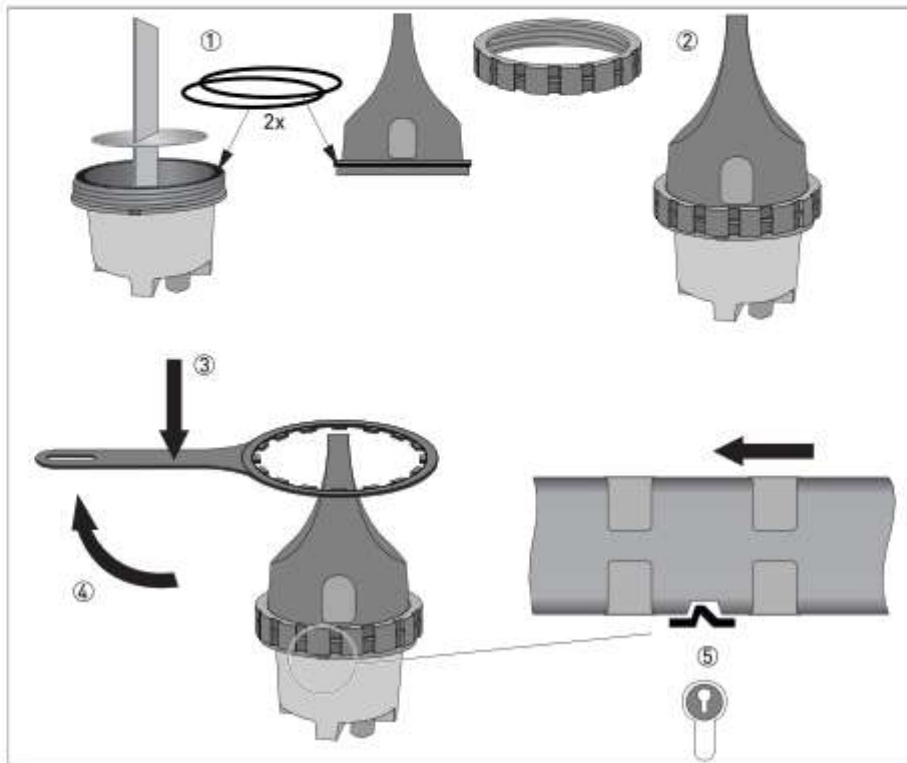

Figure 3-2: Opening the housing

- ① Put the wrench over the housing.
- ② Turn it counter clockwise to open the housing.

Proceed similarly to close the housing; use the tool to tighten the ring until the clip locks.



**Figure 3-3: Closing the housing**

- ① Check that the two O-rings are clean and correctly placed.
- ② Put the top housing in place with the ring around it.
- ③ Put the wrench in position.
- ④ Turn the wrench clockwise to close the housing.
- ⑤ Stop tightening if the clip locks.

*Do not tighten beyond the clip*

### 3.2.3 Inserting the SIM-card

*Open the housing in a clean and dry location using the opening wrench.*

On the SIM-card, the PIN code required option must be deactivated and the SMS server centre number saved; if not, insert the card into a cell-phone and modify these two parameters.

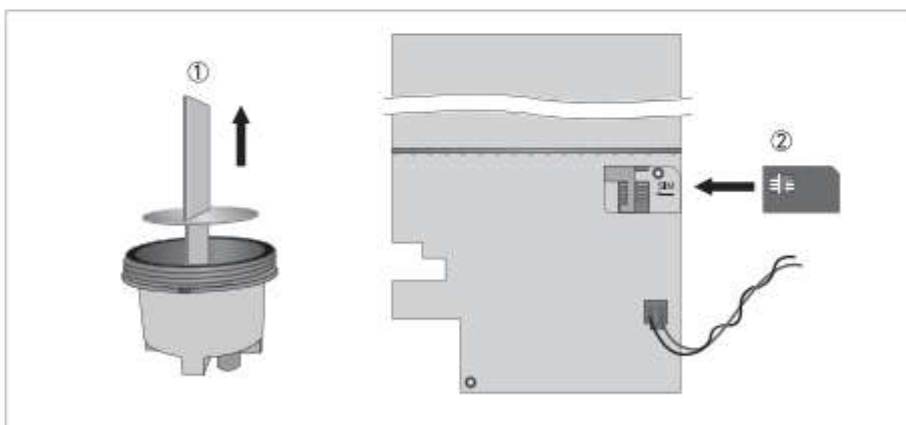

**Figure 3-4: Inserting the SIM card**

- ① Open the housing and take out the electronics.
- ② Insert the SIM card as shown.

### 3.3 Diagnostics

To save energy during storage and transport, the product is delivered "Powered down". Hold the key for 8 seconds to start the unit.

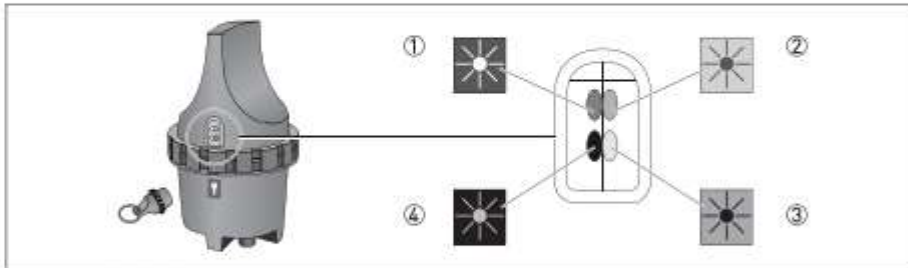

Figure 3-5: Indicator lights

- ① GREEN LED: GSM network registration and SIM Card OK
- ② YELLOW LED: Very good GSM reception level
- ③ ORANGE LED: Correct GSM reception level
- ④ BLUE LED: Unit is awake for tests and communication

#### Main visual tests

- Is the unit running?
  - ...to find out, hold the key in front of the printed lock for 2 seconds:
    - The BLUE LED flashes: the unit is running
    - The GREEN AND YELLOW LED's light: the unit is down
- Starting up the unit
  - If the unit is down, hold the key for 8 seconds in front of the printed lock, until the GREEN and YELLOW LED's are flashing. Then release the key, all LED's are turned off.
- Unit wake-up for communication tests
  - Hold the key in front of the lock printed on the case. The BLUE LED lights, flashes and then stabilizes: the unit is ready for communication tests.
- GSM reception level
  - After unit wake-up + several seconds (network registration time). If the ORANGE and YELLOW LED's do not light the reception level is too low.
- GSM communication diagnostics
  - During tests, the BLUE LED flashes
- *After remaining idle for 5 minutes, the unit automatically switches to standby mode (either in the absence of communication with Softtools, or in the absence of user action): the 4 LED's are turned off.*
- *Holding the key in place for 8 seconds powers down the unit. This action is necessary during transport.*

## 4.1 Safety instructions

*All work on the electrical connections may only be carried out with the power disconnected. Take note of the voltage data on the nameplate!*

*Observe the national regulations for electrical installations!*

*Observe without fail the local occupational health and safety regulations. Any work done on the electrical components of the measuring device may only be carried out by properly trained specialists.*

*Look at the device nameplate to ensure that the device is delivered according to your order. Check for the correct supply voltage printed on the nameplate.*

## 4.2 Inputs of the KGA 42

It is possible to connect a pulse or analog output of any flowmeter to one of the analog or digital inputs of the KGA 42.

*The maximum voltage on each input is 12 V!*

*Disconnect the cable from the housing to facilitate the connection of the various devices.*

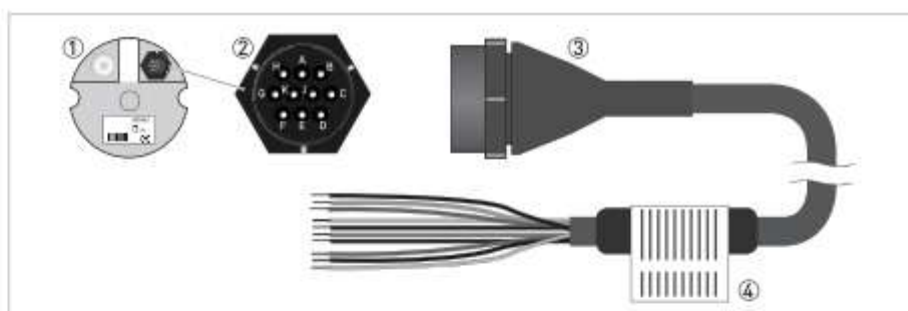

**Figure 4-1: I/O cable**

- ① Bottom side of the KGA 42
- ② Military grade I/O connector
- ③ I/O cable
- ④ Label with explanation of colors



Output of converter	Input of KGA 42	Used wires
Pulse outputs (passive) / Status outputs (passive)	DI 1	white and brown (or black)
	DI 2	green and brown (or black)
	DI 3	yellow and brown (or black)
	DI 4	red and brown (or black)
Analog outputs (passive)	AI 1	"+" on purple; "-" on pink
	AI 2	"+" on blue; "-" on grey
Analog outputs (active)	AI 1	"+" on pink; "-" on brown (or black)
	AI 2	"+" on grey; "-" on brown (or black)
		purple and blue are not used



### KROHNE product overview

- Electromagnetic flowmeters
- Variable area flowmeters
- Ultrasonic flowmeters
- Mass flowmeters
- Vortex flowmeters
- Flow controllers
- Level meters
- Temperature meters
- Pressure meters
- Analysis products
- Measuring systems for the oil and gas industry
- Measuring systems for sea-going tankers

Head Office KROHNE Messtechnik GmbH  
Ludwig-Krohne-Str. 5  
D-47058 Duisburg (Germany)  
Tel.: +49 (0)203 301 0  
Fax: +49 (0)203 301 10389  
info@krohne.de

The current list of all KROHNE contacts and addresses can be found at:  
[www.krohne.com](http://www.krohne.com)

**KROHNE**